



# Instruction Manual



Effective: June 01, 2011

---

## Oildyne 108/118 and 165/175 Series Hydraulic Power Units



<b>Table of Contents</b>	<b>Page</b>
Labels	3
Introduction	4
Explanation of Warning Labels	4
Description	4
Preparation for Use	10
Installation	10
Start-Up Procedures	15
Special Tools	16
Safe Operating Procedures	16
Operation	16
Maintenance	16
Recommended Spare Parts	23
Troubleshooting	23
Declaration of Incorporation	27



## **WARNING – USER RESPONSIBILITY**

FAILURE OR IMPROPER SELECTION OR IMPROPER USE OF THE PRODUCTS DESCRIBED HEREIN OR RELATED ITEMS CAN CAUSE DEATH, PERSONAL INJURY AND PROPERTY DAMAGE.

This document and other information from Parker-Hannifin Corporation, its subsidiaries and authorized distributors provide product or system options for further investigation by users having technical expertise. The user, through its own analysis and testing, is solely responsible for making the final selection of the system and components and assuring that all performance, endurance, maintenance, safety and warning requirements of the application are met. The user must analyze all aspects of the application, follow applicable industry standards, and follow the information concerning the product in the current product catalog and in any other materials provided from Parker or its subsidiaries or authorized distributors.

To the extent that Parker or its subsidiaries or authorized distributors provide component or system options based upon data or specifications provided by the user, the user is responsible for determining that such data and specifications are suitable and sufficient for all applications and reasonably foreseeable uses of the components or systems.

## **Offer of Sale**

Please contact your Parker representation for a detailed 'Offer of Sale'.

**How to read the product label with the 108/118 and 165/175 Series Power Units**

**108/118 and 165/175 Power Units with DC Motor**

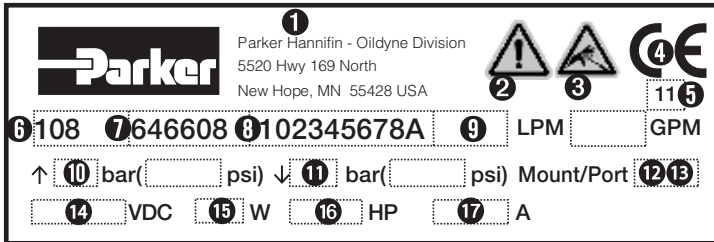

1. Name & address of manufacturer
2. WARNING - see page 4
3. WARNING - see page 4
4. CE Mark (if applicable)
5. Year of product manufacture (if CE marked)
6. Product type - 108/118/165/175
7. Part number
8. Unique identifier/serial number
9. Flow rate
10. UP port pressure setting
11. DN port pressure setting
- 12/13. Mount type / Port callout
14. Motor voltage
15. Motor rated watts
16. Motor rated horsepower
17. Motor Amperage draw

**108/118 Power Units with AC Motor**

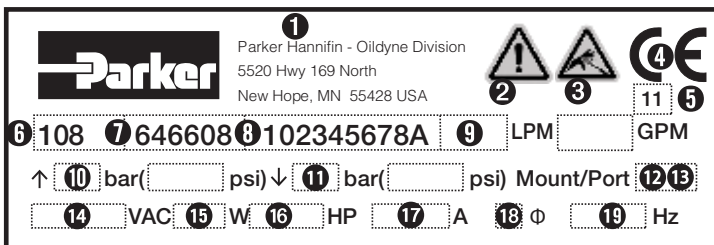

1. Name & address of manufacturer
2. WARNING - see page 4
3. WARNING - see page 4
4. CE Mark (if applicable)
5. Year of product manufacture (if CE marked)
6. Product type - 108/118
7. Part number
8. Unique identifier/serial number
9. Flow rate
10. UP port pressure setting
11. DN port pressure setting
- 12/13. Mount type / Port callout
14. Motor voltage
15. Motor rated watts
16. Motor rated horsepower
17. Motor Amperage draw
18. Motor phase
19. Motor Hz

**Introduction**

This manual provides descriptive operation and maintenance instructions for 108/118 Series and 165/175 Series Hydraulic Power Units manufactured by the Parker Hannifin Corporation, Oildyne Division. Any additional information may be obtained from Parker by referencing the unit part number stamped on the product label or by contacting your local authorized Parker Oildyne Distributor.

Some of the Information in this manual may not apply to all power units. Information about custom units may require service and application information from other sources.

**Warning**

**This Instruction Manual should be read in its entirety and understood prior to installing and operating Parker Oildyne 108/118 Series and 165/175 Series Hydraulic Power Units.**

It is imperative that personnel involved in the installation, service, and operation of these Parker Oildyne units be familiar with how the equipment is to be used. They should be aware of the limitations of the system and its component parts, and have knowledge of good hydraulic practices in terms of safety, installation, and maintenance.

**Explanation of Warning Labels**

The following labels will be used in this Instruction Manual and on all applicable Parker Oildyne products.



**Be careful; take precautions; examine instructions before operation.**



**There may be hydraulic liquid under pressure. Do not open unit or break pipe connections until hydraulic pressure has been released.**

**Description**



The 108 Series and 118 Series are identical power units with the exception of the porting surfaces. Likewise, the 165 Series and the 175 Series are identical with the exception of the porting surfaces.

Refer to ordering/shipping paperwork to determine the exact model code of your power unit. That model code can be used to evaluate the performance data in this manual. See page 21 for the Standard Product Model Code. The model code will appear similar to this:  
108AMS32-CLL-4V-15-08-B.

The 108/118 Series and 165/175 Series Hydraulic Power Units consist of an AC or DC electric motor (the 165/175 Series is available only with a DC motor), fixed displacement gear pump, relief valve(s), optional check valve(s), optional two position solenoid valve, and a reservoir. Multiple circuit types are available. The gear pump is driven through a coupling located between the electric motor shaft and the pump drive shaft. These power units are designed to be operated with an integral reservoir as the gear pumps themselves are not a sealed design.

For dimensional drawings, see pages 5 - 7.

108 Series ports:

- 7/16-20 SAE-4 o-ring type (model code -1)
- 7/16-24 inverted flare (model code -2)
- 1/8 in NPSF (model code -3)
- 1/8 in BSPP (model code -4)

165 Series ports:

- 7/16-20 SAE-4 o-ring type (model code -1)
- 1/8 in BSPP (model code -4)

108/165 Series port face example is shown below:



The 118/175 Series versions provide a flat port surface suitable for mounting a manifold; the ports are not threaded, as shown below:



For power unit schematics, see pages 8 - 9.

The life expectancy of Parker Oildyne hydraulic power units is directly tied to the frequency of use, the product in which it is incorporated and the application.

Shipping weights for the 108/118/165/175 Series Power Units range from 2.7 Kg (6 lbs) to 6.8 Kg (15 lbs). All combinations of these power units are light enough that one person can easily carry them alone.

Pressure Capability (depends on pump/motor):

- 108/118 Series: Up to 207 bar (3000 psi) maximum
- 165/175 Series: Up to 241 bar (3500 psi) maximum

Flow Output (at no load):

- 108/118 Series AC motor: .5 - 1.9 lpm (.15 - .5 gpm)
- 108/118 Series DC motor: .6 - 3.6 lpm (.16 - .9 gpm)
- 165/175 Series DC motor: 2.8 - 5.3 lpm (.75 - 1.4 gpm)

# Overall Dimensions

## 108 Series and 165 Series With 'C' Reservoir

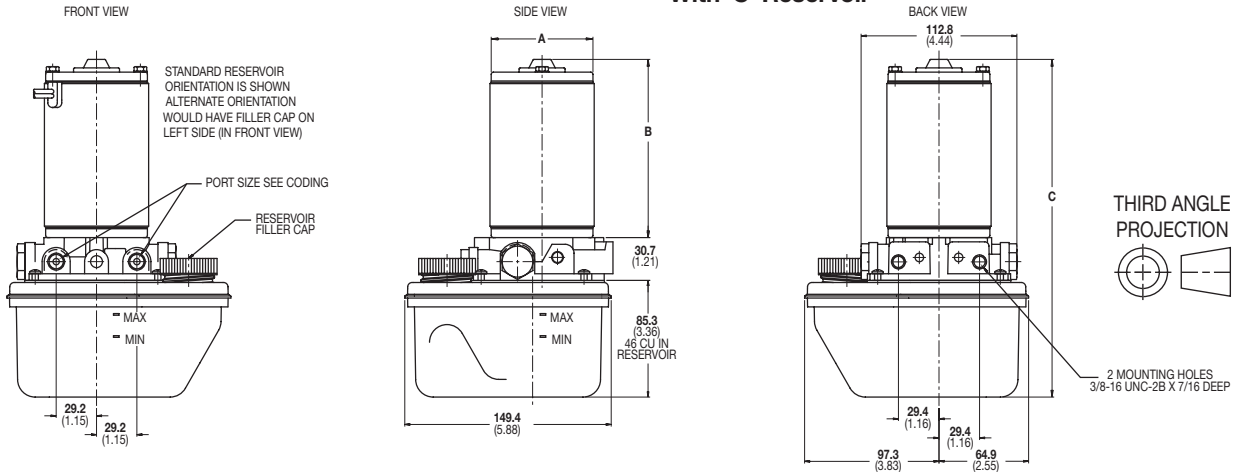

## With Solenoid Valve and 'D' Reservoir

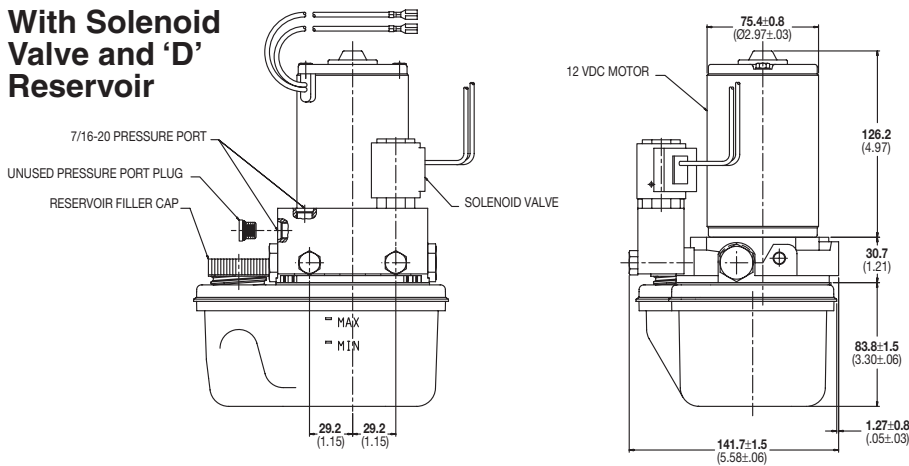

Motor Dimensions ±.1.3 (±.050)			
	A	B	C
AE/BE	75.4 (2.97)	126.2 (4.97)	241.3 (9.50)
AM/BI	95.8 (3.77)	151.4 (5.96)	266.4 (10.49)
IA	75.4 (2.97)	128.8 (5.07)	244.1 (9.61)
HA/HD	100.1 (3.94)	161.0 (6.34)	276.4 (10.88)

# Reservoir Dimensions

Note: refer to page 7 for information on the H, I, J, P, Q, R and S reservoirs.

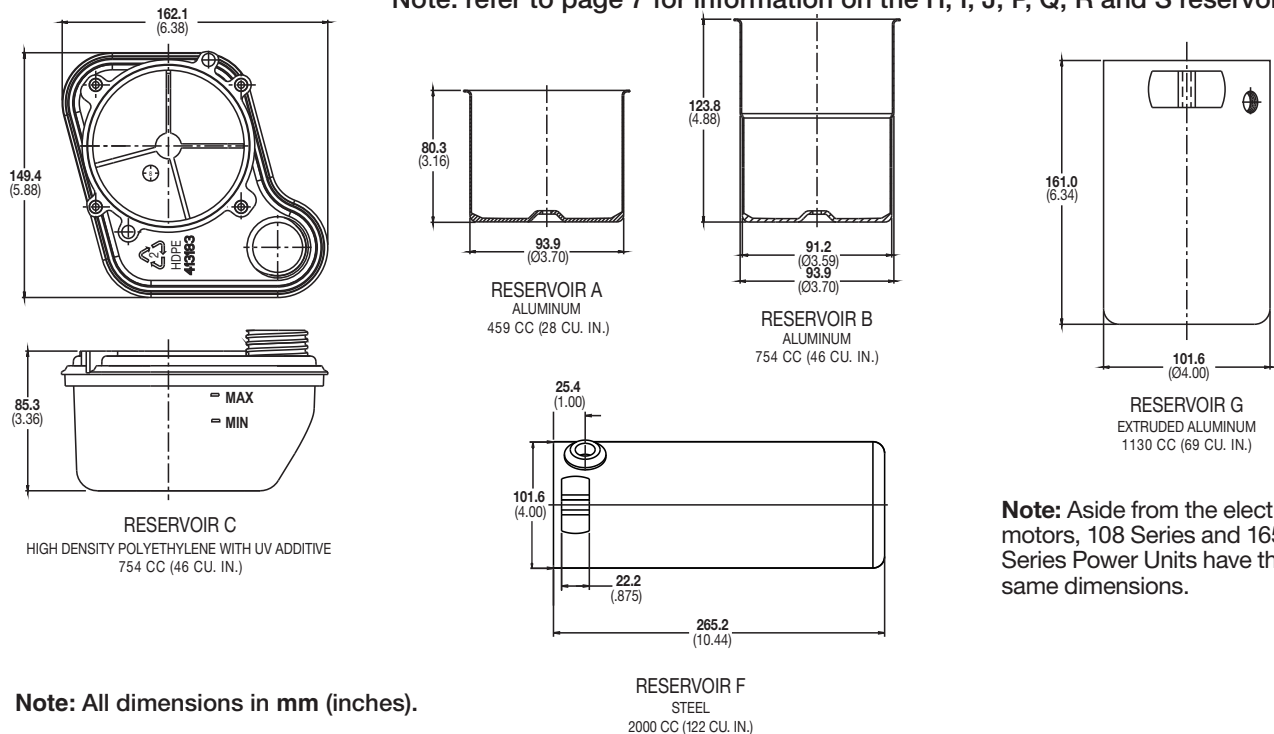

**Note:** Aside from the electric motors, 108 Series and 165 Series Power Units have the same dimensions.

**Note:** All dimensions in mm (inches).

# Dimensions

## 165 Series With G reservoir

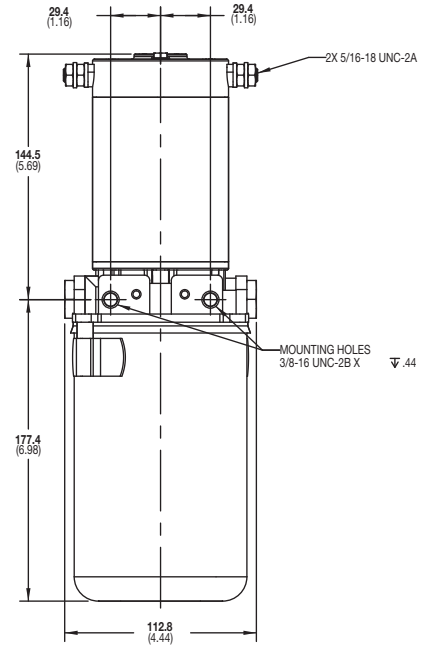
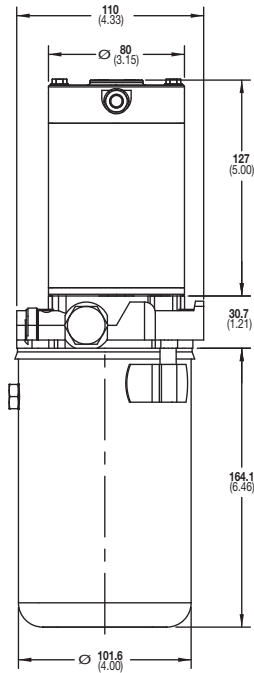
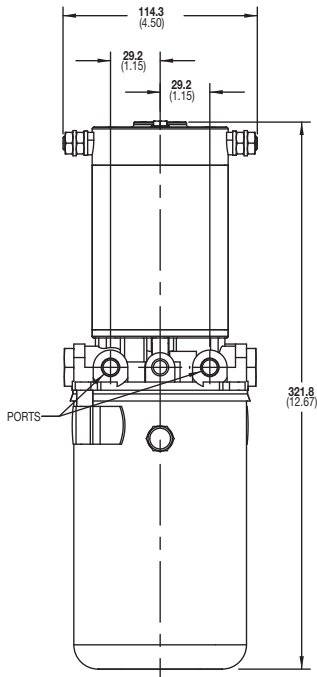

## With G reservoir and Solenoid Valve Manifold

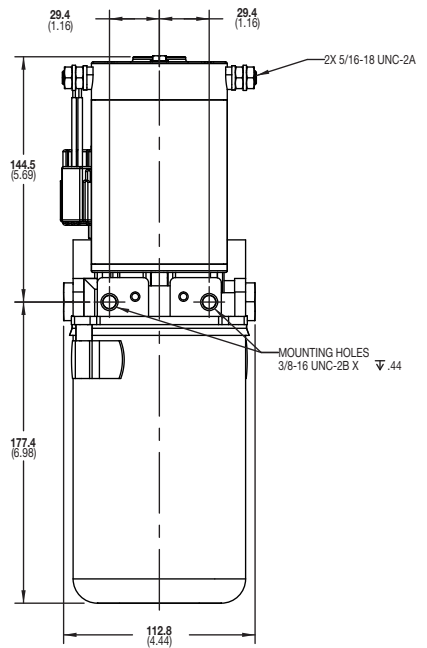
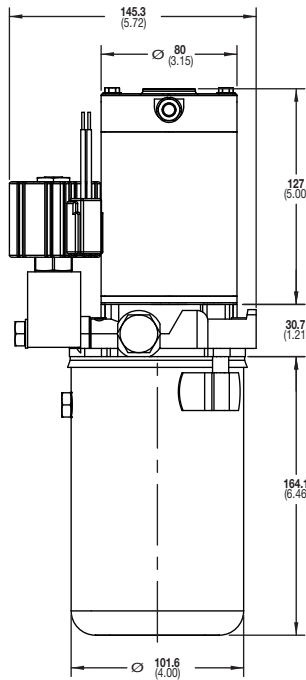
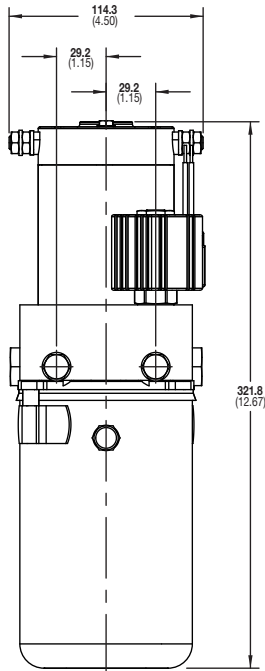
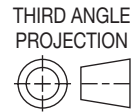

**Note:** All dimensions in mm (inches).

# Reservoir Dimensions

## 108 Series and 165 Series With H, I and J Reservoirs

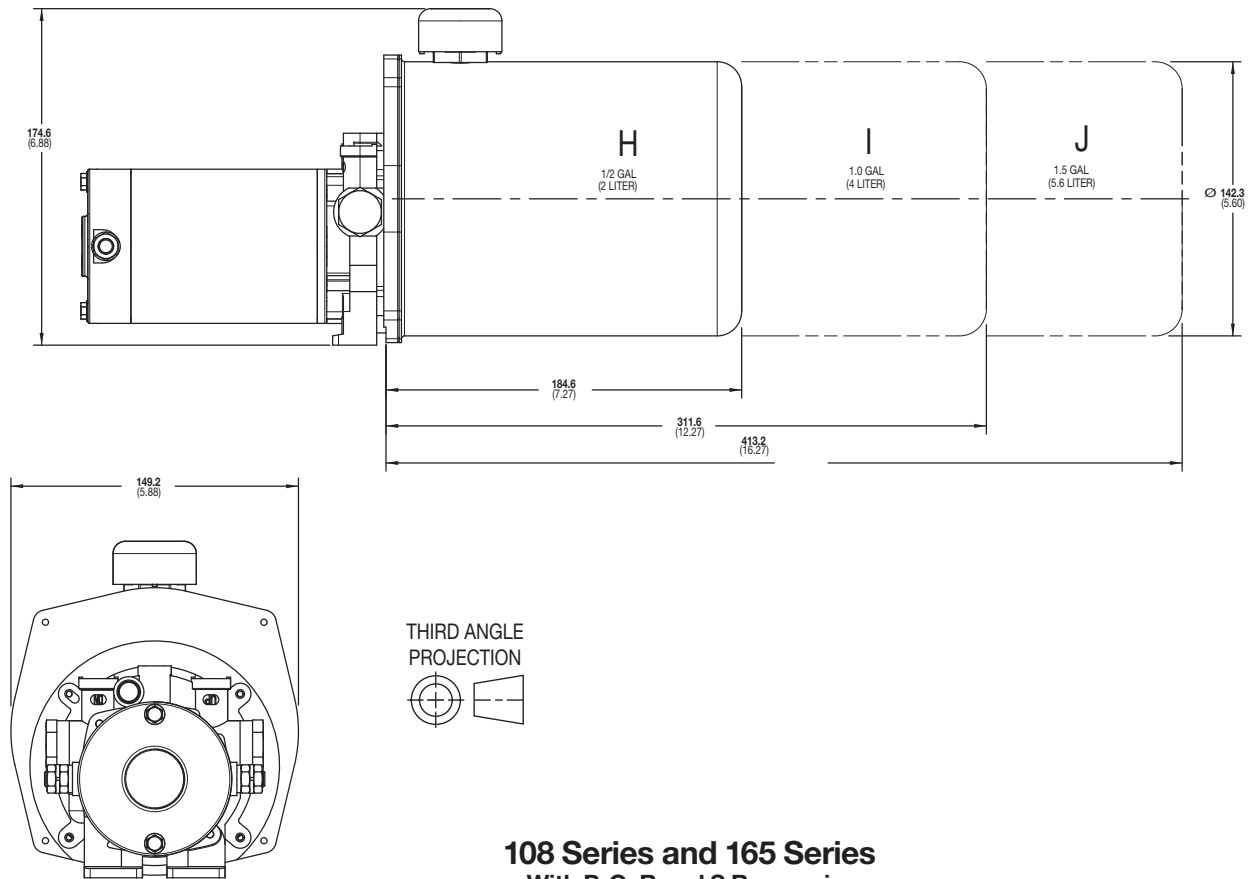

## 108 Series and 165 Series With P, Q, R and S Reservoirs

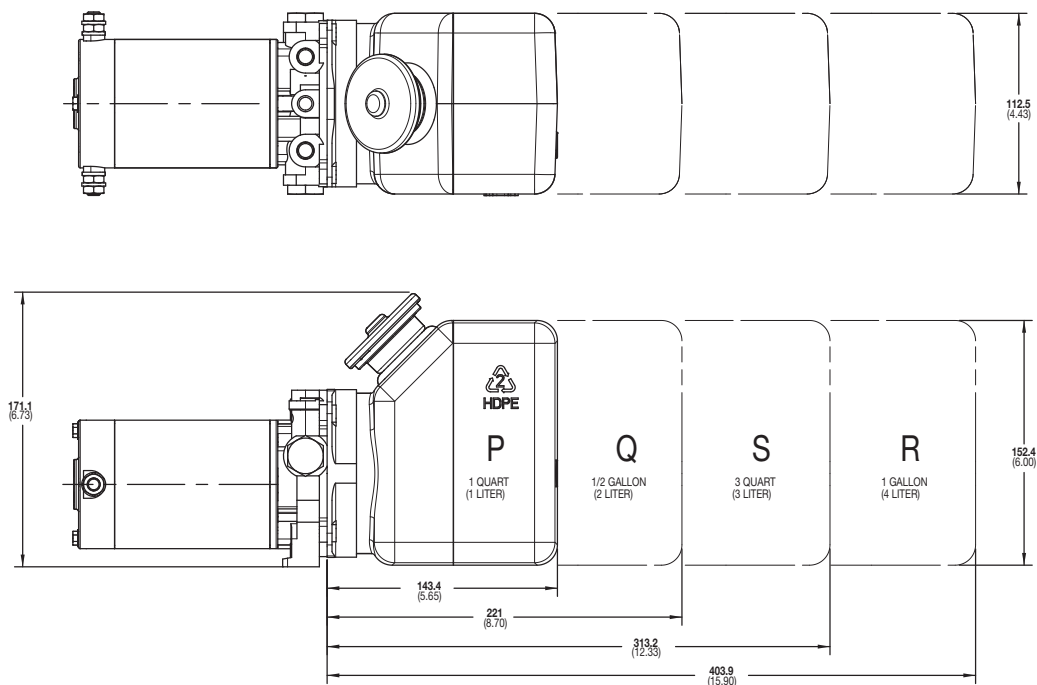

**Note:** All dimensions in mm (inches).

# Single Direction Circuits

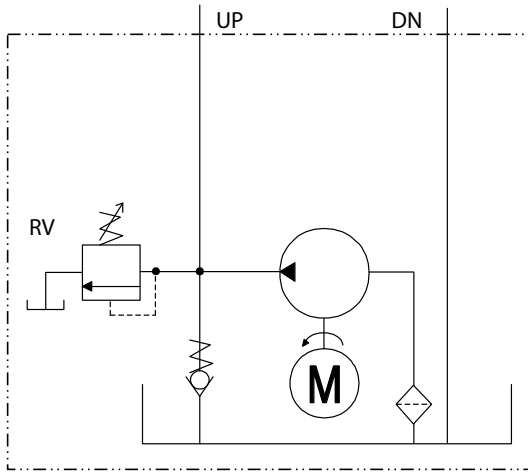

108/118 and 165/175 Series NN Circuit

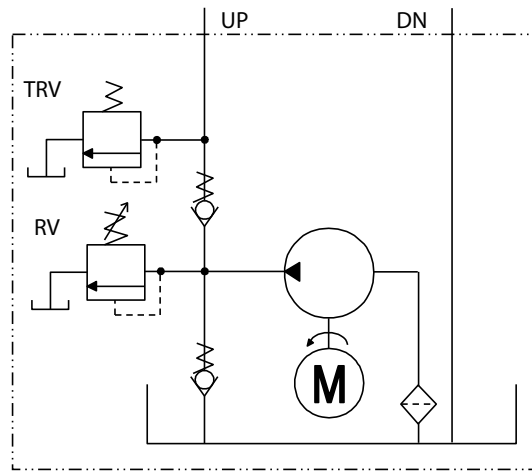

108/118 and 165/175 Series WW Circuit

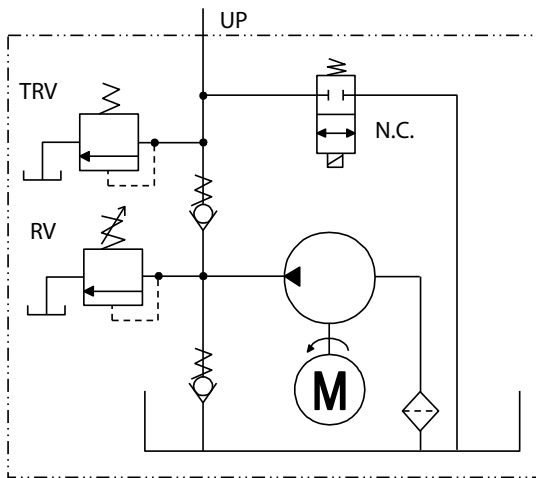

108/118 and 165/175 Series S1 - S4 Circuit (NC valve)

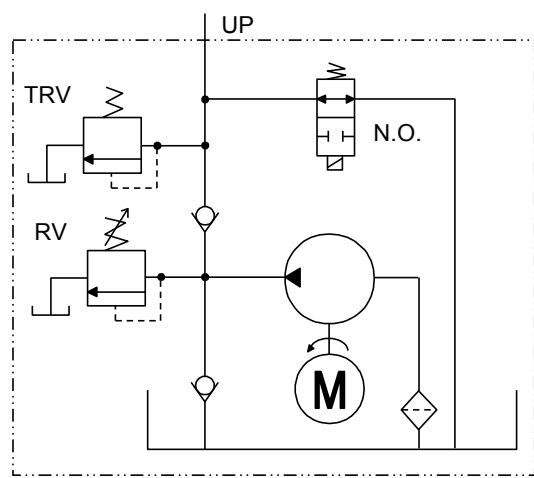

108/118 and 165/175 Series S5 - S8 Circuit (NO valve)



# Reversible Circuits

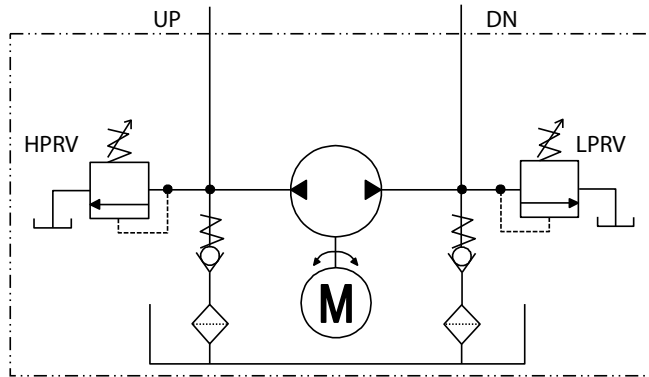

**108/118 and 165/175 Series RR Circuit  
 (Reversible)**

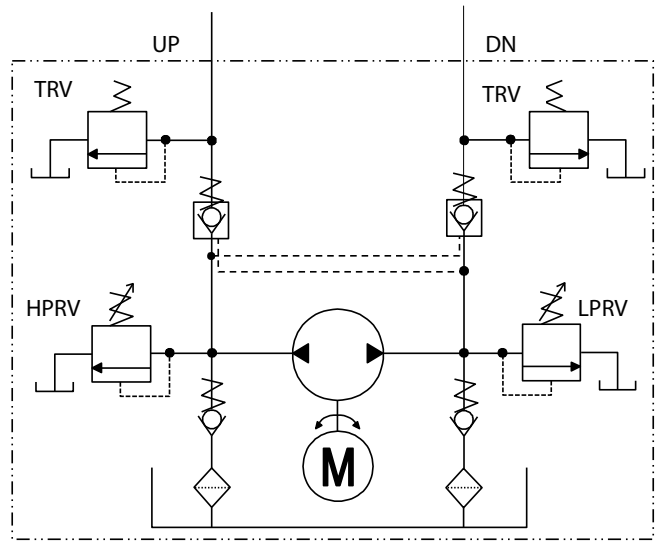

**108/118 and 165/175 Series LL Circuit  
 (Reversible Locking)**



**Note:** Back Pressure circuits (RB and LB) require the UP ports to be connected to the extend ports of cylinders.

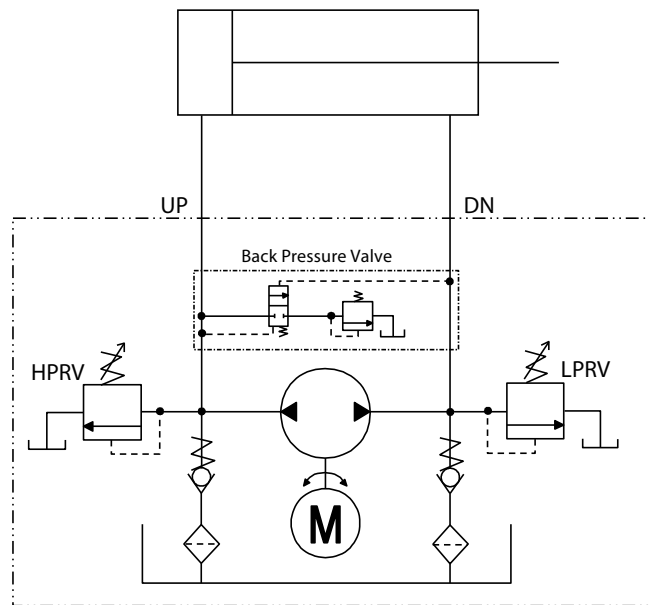

**108/118 and 165/175 Series RB Circuit  
 (Reversible with Back Pressure)**

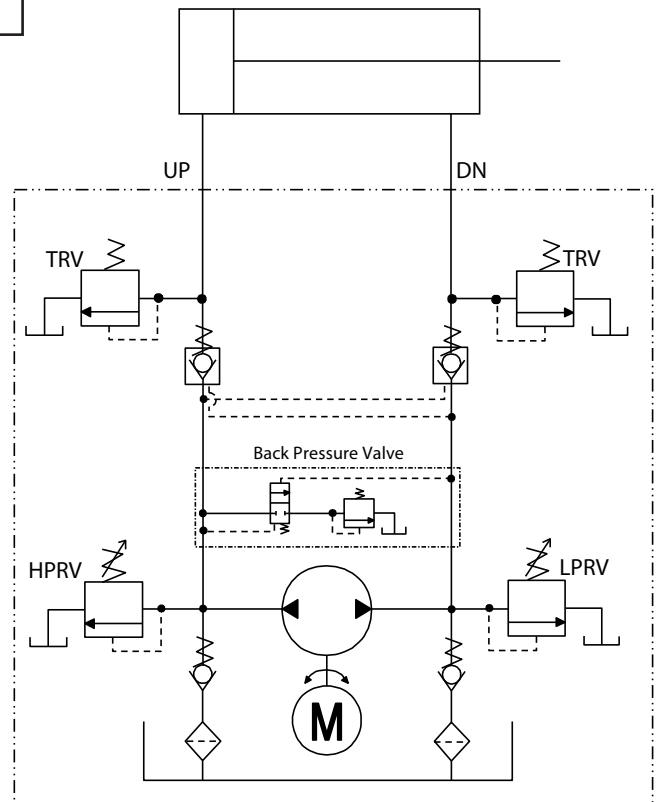

**108/118 and 165/175 Series LB Circuit  
 (Reversible Locking with Back Pressure)**

## Preparation for Use and Installation

The 108/118 Series DC motors are available in two types: Permanent Magnet (PM) and Series Wound (SW).

The 165/175 Series uses DC Permanent Magnet (PM) motors.

Motor Ratings (nominal):

- 108/118 Series AC motor 115/230 VAC: 246 W
- 108/118 Series DC PM 12, 24, 36 VDC: 250 W
- 108/118 Series DC SW 12, 24 VDC: 425 W
- 165/175 Series DC PM 12, 24 VDC: 800 W

The 108 and 165 Series Power Units provide two ports, marked UP for the left hand port and DN for the right hand port. In standard power unit configurations, the UP port is the pressure port for Single Direction models and the DN port is the return port. For Reversible models, the UP and DN ports alternate as pressure ports depending on the rotation of the electric motors. See below:



The 118 and 175 Series Power Units provide a flat surface for mounting a manifold. As in the 108 and 165 Series versions, these ports are also marked UP and DN. See below:



Acceptable fluids for 108/118/165/175 Series Power Units:

- Standard Automatic Transmission Fluid (ATF)
- Most mineral based hydraulic fluids

Viscosity range: 32-64 cSt (150-300 SSU) at 38°C (100°F).

Please contact Parker Oildyne to discuss any alternate fluids.

**Parker Oildyne takes no responsibility if unapproved alternatives are used.**

Temperature Ranges for 108/118/165/175 Series:

Operating: -7 to +60°C (+20 to +140°F)

Storage: -7 to +60°C (+20 to +140°F)

Please contact Parker Oildyne for usage outside of this range.

108/118 and 165/175 Series Power Units should be installed indoors in a clean environment.

**108/118 and 165/175 Series Power Units are designed for Intermittent Use Only.**

Only under very limited circumstances can a 108/118 Series Power Unit run continuously. These are when:

- The 108/118 Series 12 VDC Permanent Magnet motor is drawing less than 12.6 A
- The 108/118 Series 24 VDC Permanent Magnet motor is

## Oildyne 108/118 and 165/175 Series Hydraulic Power Units

drawing less than 9.6 A

The Series Wound motors are not designed for continuous duty. The 108/118 Series 115 VAC and 230 VAC motors are capable of operating a maximum of 5 minutes on continuously. The AC motors must then be off until they have cooled down to the ambient temperature. This could take 90 to 120 minutes, depending on the ambient conditions. The 165/175 Series PM motors are not intended for continuous operation. For Motor Duty Cycle Characteristics, see pages 17 - 20.

The 108/118 Series and 165/175 Series Power Units are intended to be used in a variety of applications, specified by the customer, where pressurized hydraulic fluid is required to move an actuator, charge an accumulator or supply test equipment.

Parker Hannifin Corporation takes no responsibility for the safety of any unit if it is not used for the intended purposes detailed in this Instruction Manual.

Some examples of abnormal uses of this unit would include:

- Use of unit with higher pressure than that for which it was intended
- Use with a higher or more frequent duty cycle than that for which it was intended
- Use with higher or lower voltage than required for optimal use
- Use in a mounting orientation other than that for which it was designed
- Use of fluids not recommended

### Preparation for Use

#### Unpacking and Checking

All units were carefully packed in containers or boxes, and may or may not be on skids. In any case, do not remove anything from the skid or any packaging until it has been carefully checked for damage that may have occurred in transit. Report all damage immediately to the carrier and send a copy to the vendor.

All open ports on the power unit were plugged at the factory to prevent the entry of contamination. These plugs must not be removed until just before piping connections are made to the unit.

#### Storage

If the unit is not going to be installed immediately, it should be stored indoors, covered with a waterproof sheet, with all open ports plugged. If long term storage is expected (six months or more) we recommend filling the reservoir completely with clean hydraulic fluid to prevent the entry of moisture.

### Installation

#### Locating Power Unit

The unit should preferably be installed indoors in a clean, dry environment with an ambient temperature of 16 to 37°C (60 to 100°F). However, if this is not possible, mount the power unit in a location that is protected from direct liquid contact.

Parker Oildyne power units should not be installed where there is a risk of objects falling from overhead or where there is any risk of impact with external objects.

#### Mounting the power unit

108/118 and 165/175 Series Power Units are factory assembled complete and tested based on the model codes ordered by the customers. They are also assembled specifically for the

**Installation**

orientation ordered, whether vertical mount (motor above reservoir) or horizontal mount (ports facing up). The power unit adapter section, located between the electric motor and the reservoir, provides two mounting holes by which the power unit can be mounted to the customer's machine. These holes are located on the mounting foot, 180° from the outlet ports. The mounting holes are threaded either 3/8-16 UNC-2B x 7/16 in deep (for 108/118 Series ordered with 7/16-20, 7/16-24 or 1/8 in NPSF ports and 165/175 Series ordered with 7/16-20 ports) or M10 x 1.5 x 15.2 mm deep (for both 108/118 Series and 165/175 Series ordered with 1/8 in BSPP ports).



Mount the power unit securely using the threaded holes provided in the foot of the adapter. Recommended mounting torques are 19.7 – 22.6 Nm (175 - 200 in-lbs) for both the 3/8-16 bolts and the M10 x 1.5 bolts.

**It is strongly recommended that the surface to which the power unit is mounted be bonded to earth to provide proper grounding in the event of a lightning strike.**

**Electrical Service Connections**

Connect the motor to the power source following the good practices as outlined in the national electric codes and any local codes which may apply. Verify that the available voltage is the same as the voltage identified on the label.

Refer to the performance data on pages 17 - 20 for your particular model to determine the current ratings needed for your electrical controls. Parker Oildyne does not supply controls for the 108/118 and 165/175 Series Power Units. However, the HA and HD motors (both AC) are shipped with a start relay and a start capacitor assembly specific to the motor voltage being used. These two components **MUST** be included in the controls circuit designed by the customer. Attempting to operate the HA and HD motors without the supplied start relay and start capacitor will result in unsatisfactory performance and excessive motor heat. **Parker Oildyne will not warranty a power unit which has not been wired properly.**

**Motor Electrical Connections**

AE	2 leads: 12 gauge
BE, IA	2 leads: 14 gauge
AM, BI	3 leads: 12 gauge
AY, BY	2 terminals: 5/16-18 UNF-2A
HA, HD	7 leads: 18 gauge

**Instruction Manual  
Oildyne 108/118 and 165/175 Series  
Hydraulic Power Units**

**BASIC MOTOR CONNECTIONS, BY MOTOR CODE (refer to model code on shipping/ordering paperwork)**

**108/118 Series PM Motors: AE only (12 VDC)**

1) For Single Direction only, and Reversible with UP port pressure:

- BLUE + 12 VDC
- GREEN Ground

2) Reversible with DN port pressure:

- BLUE Ground
- GREEN + 12 VDC

**108/118 Series PM Motors: BE/IA only (24/36 VDC)**

1) For Single Direction only, and Reversible with UP port pressure:

- BLACK + 24 or 36 VDC
- ORANGE Ground

2) Reversible with DN port pressure:

- BLACK Ground
- ORANGE + 24 or 36 VDC

**108/118 Series SW Motors: AM/BI (12/24 VDC)**

1) For Single Direction only, and Reversible with UP port pressure:

- BLUE + 12 or 24 VDC
- GREEN unused
- BLACK Ground

2) Reversible with DN port pressure:

- BLUE unused
- GREEN + 12 or 24 VDC
- BLACK Ground

**108/118 Series HA Motors (115 VAC)**

1) For Single Direction only, and Reversible with UP port pressure:

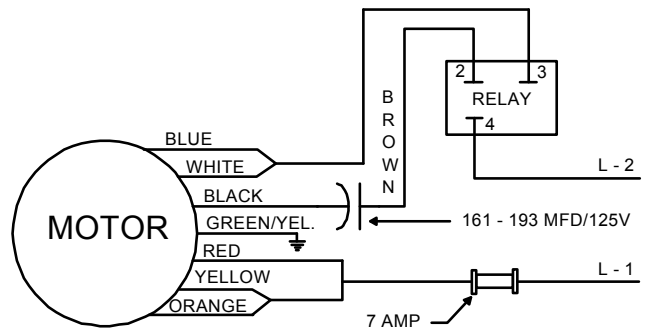

**115 VOLTAGE CONNECTION**

2) Reversible with DN port pressure (Black and Red wires are interchanged):

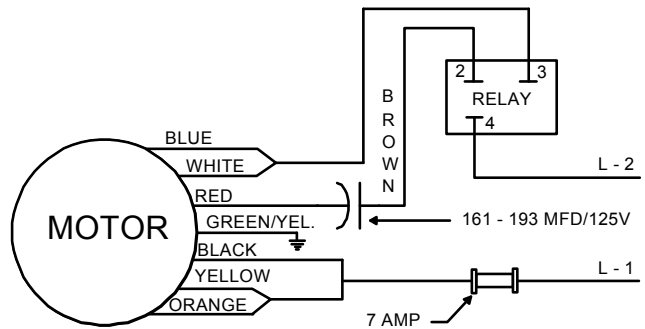

**115 VOLTAGE CONNECTION**

**108/118 Series HD Motors (230 VAC)**

1) For Single Direction only, and Reversible with UP port pressure:

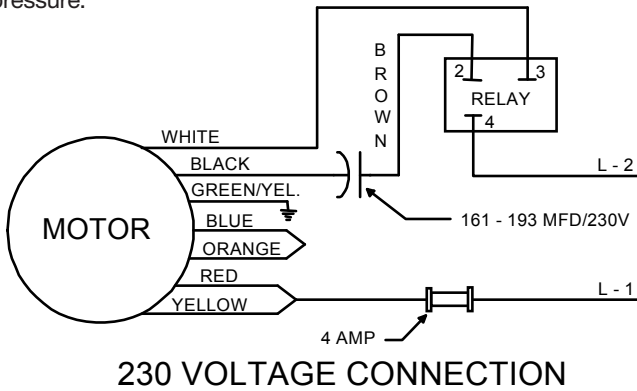

2) Reversible with DN port pressure (Black and Red wires are interchanged):

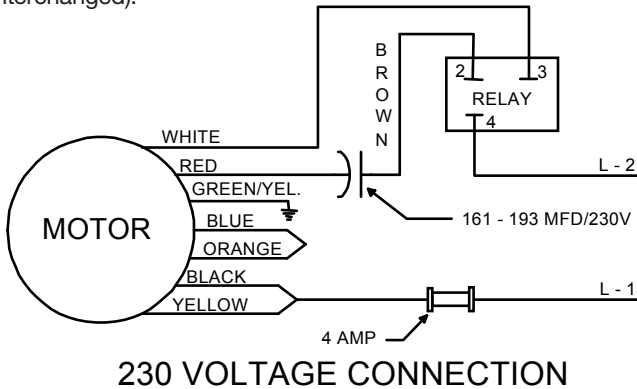

**165/175 Series AY Motor**

1) For Single Direction only, and Reversible with UP port pressure:

- Terminal 1      Ground
- Terminal 2      + 12 VDC

2) Reversible with DN port pressure:

- Terminal 1      + 12 VDC
- Terminal 2      Ground

**165/175 Series BY Motor**

1) For Single Direction only, and Reversible with UP port pressure:

- Terminal 1      Ground
- Terminal 2      + 24 VDC

2) Reversible with DN port pressure:

- Terminal 1      + 24 VDC
- Terminal 2      Ground

**Suggested reversing electrical schematics  
 108/118 Series PM Motors**

**Wiring Diagram: AE & BE**

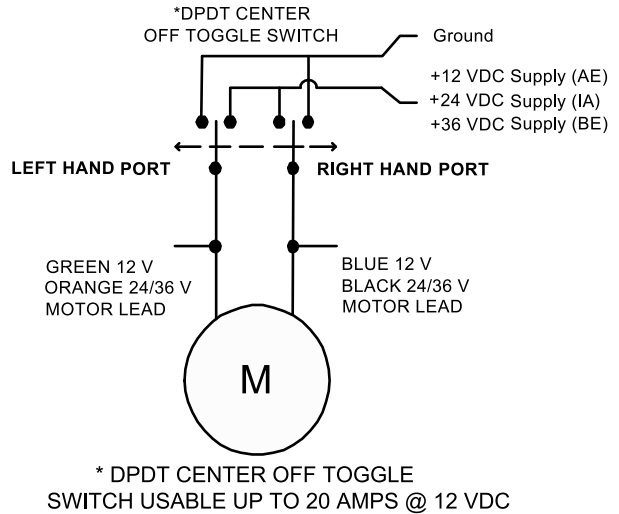

**NOTE:** if a Double Pole, Double Throw toggle switch with a current rating for your application is not available, refer to the schematic "108/118 AE/BE/IA and 165/175 AY/BY Motors" on the next page for a possible reversing circuit using control relays.

**Wiring Diagram: AM & BI**

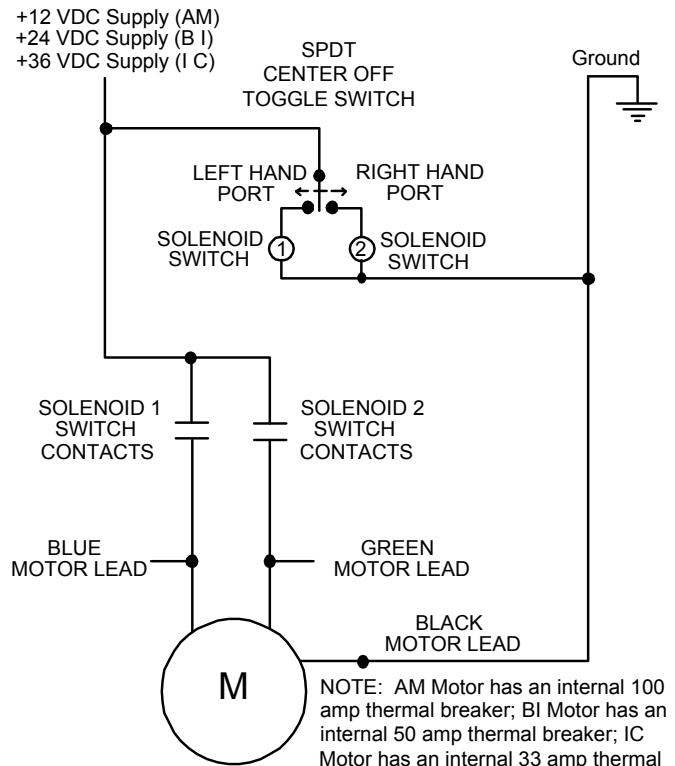

**Suggested reversing electrical schematics  
 108/118 Series HA Motors (115 VAC)**

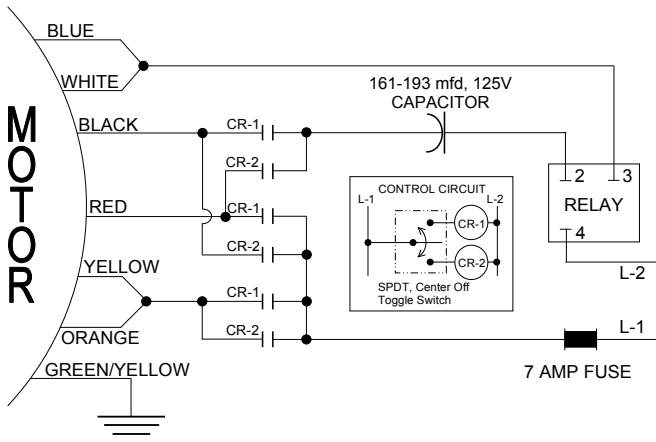

**108/118 Series HD Motors (230 VAC)**

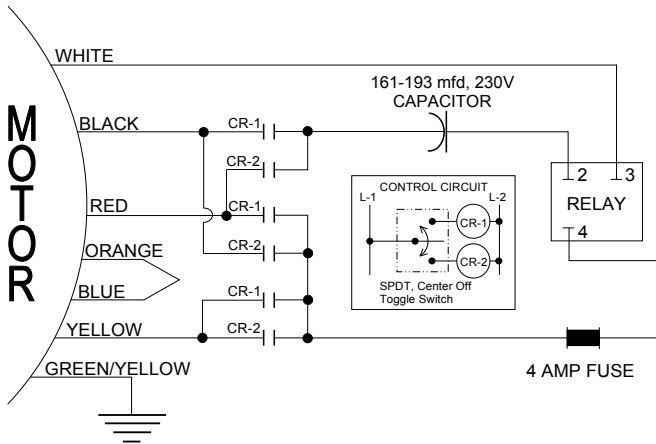

**Suggested reversing electrical schematics**

**108/118 AE/BE/IA and 165/175 AY/BY Motors**

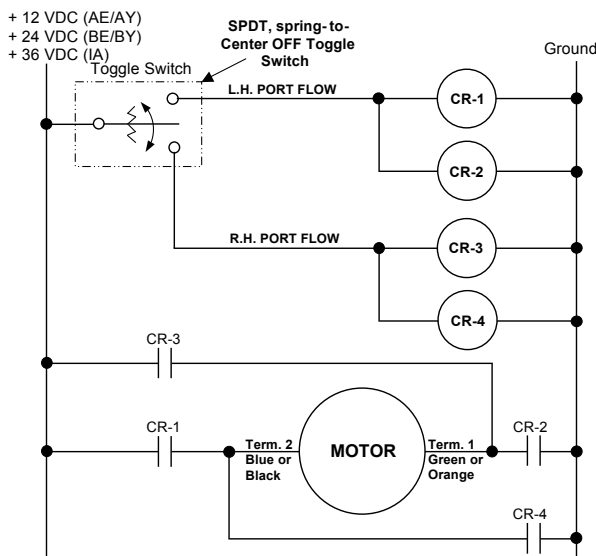

**Supply and Return Connections**

108 Series ports:

- 7/16-20 SAE-4 o-ring type (model code -1)
- 7/16-24 inverted flare (model code -2)
- 1/8 in NPSF (model code -3)
- 1/8 in BSPP (model code -4)

165 Series ports:

- 7/16-20 SAE-4 o-ring type (model code -1)
- 1/8 in BSPP (model code -4)

Fluid connectors and conductors installed by the customer should be selected based on an acceptable safety margin for the maximum pressure required in the application. 108/118 Series Power Unit are capable of up to 207 bar (3000 psi); 165/175 Series Power Units are capable of up to 241 bar (3500 psi). SAE-4 ports are recommended when selecting a power unit due to the integrity of the o-ring seal. 1/8 in NPSF ports will use standard 1/8 in NPT tapered fittings. **Use great caution when installing these tapered fittings as the aluminum adapter casting will crack if the fittings are overtightened.** Use of a thread sealant, whether a PTFE tape or paste, is permitted, however, ensure neither the excess tape nor paste is allowed to enter the fluid passageways as these contaminants could cause problems.

The 118/175 Series versions will not have connectors or conductors installed directly, but, instead, will have a customer-supplied manifold bolted to the flat port surface. Fluid connectors and conductors will be installed into the customer-supplied manifold.

Line sizes should be determined based on oil flow, operating pressure and allowable pressure drop between the power unit and actuator.

**Warning**

Check to insure that the proper rated hose or pipe is used on pressure lines.

One of the key ingredients for good service and long life from a hydraulic system is cleanliness. Because most dirt infiltrates a hydraulic system during installation, we recommend the following:

- All open ports on the power unit, cylinders, etc. must remain plugged with tape or plastic plugs until just before the hydraulic connections are made.
- All interconnecting tubing, pipe, or hose should be clean, and free of rust, scale and dirt. The ends of all connectors should be plugged until just before they are to be installed in the system.
- All openings in the reservoir such as the filler/breather or access end covers holes must remain closed during installation.

**Hydraulic Fluids**

Follow all vendor-supplied instructions for safe handling, use and disposal of the fluid selected for operation in this power unit.

It is strongly recommended that the customer have available the MSDS for the fluid chosen for use in the 108/118 and 165/175 Series Power Units. Follow all instructions should the fluid spill or come in contact with an operator.

It is critical that the reservoir be filled with an approved fluid prior to startup of the power unit. Any system failures due to improper fluids being used or operating without the reservoir being full of an approved fluid will result in voiding the warranty.

The reservoir must be filled with clean fluid through the filler



**Installation**

cap/breather. The filler cap may be located in the adapter casting between the UP and DN ports, next to the DN port on the motor side, or in the reservoir.

The type of fluid must be compatible with the Nitrile (Buna N) seals used on the power unit, and must comply with the recommendations of the manufacturers of the component parts. Acceptable fluids include standard Automatic Transmission Fluid (ATF) and most mineral based hydraulic fluids with viscosities between 32 cSt (150 SSU) and 64 cSt (300 SSU) at 38°C (100°F). For fluids other than these, contact Parker Oildyne with the details. If users wish to use alternative oil, hydraulic fluid or ATF, they are warned to check that they have the same properties as those recommended. **Parker Oildyne takes no responsibility if unapproved alternatives are used.**

**Reservoir Filling**

The filler location may be between the UP and DN ports as shown in 1) below, next to the DN port on the motor side as shown in 2) or in the reservoir as shown in 3), 4) and 5):

1) Will be either a 1/8-27 NPT thread with an 11 mm (7/16 in) hex head or a 1/4-18 NPT thread with a 14 mm (9/16 in) hex head. Tighten until snug. See below:



2) A breather/dipstick is installed in 108/118 Series Power Units using the 'A' and 'B' reservoirs in a vertical configuration. The dipstick head requires a flat-blade screwdriver with a blade width of between 9-13 mm (.35 to .5 in). After filling, with the dipstick tightened all the way in, loosen the dipstick by 1.5 turns to enable the breather function. See below:



3) 1/4-18 NPT thread with a 14 mm (9/16 in) hex head. Tighten until snug. See below:



4) The cylindrical steel reservoirs have filler/breathers with a 3/8-18 NPT thread. The head of the breather is circular allowing the breather to be removed and installed by hand only – no tools are necessary. Tighten until snug. See below:



**Instruction Manual  
Oildyne 108/118 and 165/175 Series  
Hydraulic Power Units**

5) The rectangular plastic reservoirs have a filler/breather which is a 'push in/pull out' design, installable by hand – no tools are required. See below:



**Reservoir volumes**

Vertical Mount (approximate)

In general, when filled to about 12 mm (.5 in) from the filler port location.

Exceptions:

A and B reservoirs filled to "FULL" mark on dipstick.  
P, Q, R and S tanks filled to the shoulder below the filler/breather. See below:



Code	Vertical Mount (motor above reservoir)			
	Total Volume		Usable Volume	
	Liter	Gallon	Liter	Gallon
A	.45	.12	.34	.09
B	.72	.19	.60	.16
C	.75	.2	.41	.11
D	.75	.2	.41	.11
F	1.6	.44	1.5	.41
G	.87	.23	.75	.20
H	1.9	.50	1.7	.45
I	3.8	1.0	3.7	.98
J	5.6	1.5	5.3	1.4
P	1.0	.28	.95	.25
Q	2.2	.58	1.9	.51
R	4.9	1.3	4.5	1.2
S	3.5	.94	3.2	.87

Horizontal Mount (approximate)

In general, when filled to about 12 mm (.5 in) from the filler port location.

Exceptions: when the filler port is located between the UP and DN ports, fill until oil just becomes visible. See below:



P, Q, R and S tanks filled to the shoulder below the filler/breather: See below:



Horizontal Mount (ports face up)				
Code	Total Volume		Usable Volume	
	Liter	Gallon	Liter	Gallon
A	.49	.13	.41	.11
B	.75	.20	.64	.17
C	Vertical Only			
D	Vertical Only			
F	1.8	.48	1.5	.40
G	1.1	.29	.91	.24
H	2.6	.71	2.4	.65
I	4.5	1.2	4.2	1.1
J	6.0	1.6	5.6	1.5
P	1.2	.32	.94	.25
Q	1.9	.52	1.5	.41
R	3.7	1.0	3.0	.80
S	2.8	.75	2.3	.61

It is strongly recommended that the customer have available the MSDS for the fluid chosen for use in the 108/118 and 165/175 Series Power Units. Follow all instructions should the fluid be spilled or come in contact with an operator.

### Start-Up Procedures

The product label on the power unit provides the maximum current (Amperes) that the motor will draw at full power. For the AC motors used on the 108/118 Series Power Units, fuses and circuit breaker protection must conform to national electrical code and your local codes and practices. For DC motors, refer to the power unit model code and the performance curves to determine the maximum current your pump and motor combination will draw at your relief valve setting(s). Fuse and circuit breaker protection must conform to national electrical codes and your local codes and practices.

#### For Single Direction Circuits of 108 and 165 Series (codes NN and WW)

Ensure the reservoir is filled with an approved fluid. Jog the motor until oil flows from the 'UP' port. If oil does not flow from the 'UP' port, reverse the wire leads on the motor, and repeat. The pump is now primed. When using an externally mounted directional control valve (DCV), connect the tank port of the DCV to the 'DN' port of the power unit. Connect the 'UP' port of the power unit to the inlet port of the DCV. If using an externally mounted two-way release (dump) valve, tee the valve into the pressure line and plumb the oil return line to the 'DN' port. Cycle the system a few times to ensure the air is out of the circuit.

#### For Solenoid Valve Circuits of 108 and 165 Series (codes S1 to S8)

Ensure the reservoir is filled with an approved fluid. If the solenoid valve is a normally open type, energize the coil with appropriate voltage to close the valve. Jog the motor on and off until oil shows at the outlet port of the solenoid manifold. If no oil appears, check the motor wiring for the proper rotation, and then repeat. Once oil

is visible, connect one end of your fluid conductor to the power unit manifold port and tighten. Connect the other end of the fluid conductor to the actuator port, leaving the connection loose. Jog the motor again until oil appears at the actuator port, and then tighten the conductor fitting. Energize the motor now to fully rotate/extend the actuator. If a normally open valve is used, de-energize the coil to allow the oil from the actuator to return to the power unit reservoir. (Note: the oil from the actuator will only exit the actuator if an external force, or spring, is moving the actuator back to its home position.) If a normally closed valve is being used, energize the coil with the appropriate voltage to open the valve allowing the oil from the actuator to return to the power unit reservoir. Cycle the system a few times to ensure the air is out of the circuit.

#### For Reversible Circuits of 108 and 165 Series (codes RR, RB, LL, LB)

Ensure the reservoir is filled with an approved fluid. Using a port plug of your adapter's port type, plug the 'DN' port. This forces the pump to draw fluid from the reservoir instead of drawing in air from the open DN port. Jog the motor until oil flows from the 'UP' port. If oil does not flow from the 'UP' port, reverse the wire leads on the motor, and repeat. The pump is now primed.

Connect the fluid conductor to the 'UP' port and tighten. Connect the other conductor end to the piston end of a fully retracted actuator. With the conductor fitting loose, operate the power unit until oil (and no air) bleeds from the loose actuator fitting. Tighten the fitting. Refill the reservoir. Operate the power unit in the 'UP' port rotation (same direction as previously run). Continue until the actuator is fully stroked, adding only enough fluid to the reservoir to get the actuator fully stroked. (Adding too much oil at this point could cause the reservoir to overflow when the actuator is reversed.)

Remove the plug from the 'DN' port and connect one end of the second fluid conductor to it, then tighten. Jog the power unit in the 'DN' port rotation (opposite direction of earlier), until oil (with no air) flows from the loose conductor end. Connect and tighten the fluid conductor end onto the rod end actuator fitting. Operate the power unit to fully retract the actuator. Once retracted, check the oil level in the reservoir and add as needed to maintain full capacity.

Functional testing is considered complete with the successful priming of these power units and cycling of the actuators.

**NOTE: These reversible systems are not self-priming nor self-bleeding. Failure to follow these instructions can cause the power unit to not prime, not build pressure, and operate the actuator erratically.**

#### For 118 and 175 Series (all circuit codes)

Because of the variety of customer-supplied manifolds, valves and circuits which can be mounted to the 118/175 Series Power Units, please consult Oildyne for specific startup instructions. Please provide a hydraulic schematic of your circuit to assist Parker Oildyne.

#### Additional Testing

If required, any tests for radiated and conducted emissions should be performed in accordance with the Electromagnetic Compatibility (EMC) Generic Emissions standards for environments appropriate to the end use product to confirm compliance with the EMC Directive.

If required, any tests for radiated and conducted immunity should be performed in accordance with the Electromagnetic Compatibility (EMC) Generic Immunity standards for environments appropriate to the end use product to confirm compliance with the EMC Directive.

**Special Tools**

All normal service and maintenance on standard power units can be accomplished with standard hand tools. No special tools are required.

**Safe Operating Procedures**

**Should a failure of the electrical power supply occur, power should not be returned to these power units without a conscious action by the operator.**

108/118/165/175 Series Power Units using the Series Wound motors may approach 70 dB(A) at low pressure operation but testing shows these motors will average about 65 dB(A) at low pressure. At higher pressures the noise level will decrease.

All other AC and DC motors used in these power units should be well under 70 dB(A). In the unlikely event of noise levels exceeding 70 dB(A) it is recommended that ear protection be worn. If noise levels should exceed 80 dB(A) it is necessary to take measures to reduce noise. This is normally achieved by placing machinery in an acoustically lined enclosure.

Some 108/118/165/175 Series Power Units will be supplied with one or two solenoid cartridge valves. These must be operated at the voltage stated on the valve coils. Failure to do so may result in damage to the coils and valves and will also void warranty.

**108/118 and 165/175 Series Power Units are designed for Intermittent Use Only.** Only under very limited circumstances can a 108/118 Series Power Unit run continuously.

1. The 108/118 Series 12 vdc Permanent Magnet motor is drawing less than 12.6 A
2. The 108/118 Series 24 vdc Permanent Magnet motor is drawing less than 9.6 A.

The Series Wound motors are not designed for continuous duty. The 108/118 Series 115 VAC and 230 VAC motors are capable of operating a maximum of five minutes on continuously. The AC motors must then be off until they have cooled down to the ambient temperature. This could take 90-120 minutes, depending on the ambient conditions. The 165/175 Series PM motors are not intended for continuous operation. If pressure must be maintained on an actuator, let the internal check valves (if ordered) hold the pressure; do not operate the power unit over the relief valve as this will create heat which could damage the power unit. For Motor Duty Cycle Characteristics, see pages 17 - 20.

**Removal from service**

**There may be hydraulic liquid under pressure. Do not open unit or break pipe connections until hydraulic pressure has been released.**

If, for some reason, the power unit must be removed from service, follow these instructions:

1. Wear protective eye gear.
2. Remove electrical power from the motor and solenoid valve (if applicable).
3. Mechanically hold/block the actuator load to prevent its movement once pressure is relieved in the fluid conductors.
4. Only after the load is mechanically held in place, put a rag around the UP or DN port fitting and loosen the port connection. The rag should absorb oil leakage as any locked pressure is relieved. Repeat this process for the other port.
5. Immediately cap the fluid conductor ends and the power unit ports to prevent the introduction of contaminants until the power unit is reconnected.

6. When reinstalling the power unit, follow all the procedures and startup instructions given previously.

**Operating these power units with a voltage other than that called for by the ordering model code may damage the electric motor and will void the warranty. Other voltages may also cause the power unit to operate unreliably.**

For both 108/118 and 165/175 Series Power Units, standard operating and storage temperature range is -7 to +60°C (+20 to +140°F). Please contact Parker Oildyne for usage outside of this range.

**Operation**

Suitable lighting requirements for operation of this unit are the responsibility of installing manufacturer.

See pages 17 - 20 for performance information.

See pages 17 - 20 for Motor Duty Cycle Characteristics.



**There may be hydraulic liquid under pressure. Do not open unit or break pipe connections until hydraulic pressure has been released.**

**Maintenance**

Parker Oildyne power units require relatively low maintenance due to the intermittent operating nature. Any maintenance should only be conducted when units are disconnected from their power supply, depressurized and removed from service.

It is strongly recommended that the customer have available the MSDS for the fluid chosen for use in the Parker Oildyne power unit. Follow all instructions should the fluid be spilled or come in contact with an operator.

**Reservoir removal for suction screen maintenance**

The 'A' and 'B' reservoirs are held to the power unit by a single screw located at the flat end of the reservoir. These screws fasten into a 'leg' of the pump. To remove the 'A' or 'B' reservoir:

1. Wear protective eye gear.
2. Mechanically hold/block the actuator load to prevent its movement once pressure is relieved in the fluid conductors.
3. Remove electrical power from the motor and solenoid valve (if applicable).
4. Remove the oil from the tank using a siphon through the reservoir filler port. If no filler port exists in the reservoir itself, the power unit will have to be inverted to allow the oil out of the reservoir.
5. Only after the load is mechanically held in place, put a rag around the UP or DN port fitting and loosen the port connection. The rag should absorb oil leakage as any locked pressure is relieved. Repeat this process for the other port.
6. Immediately cap the fluid conductor ends and the power unit ports to prevent the introduction of contaminants until the power unit is reconnected.
7. Remove the fasteners bolting the power unit to the mounting surface.
8. Remove the reservoir filler plug or dipstick.
9. Invert the power unit to drain the fluid into a container for recycling purposes. It is recommended that upon restarting the equipment new, clean fluid is used.



# Performance Data

## 108/118 Series: Permanent Magnet Motors - AE/BE

Note: IA motor (36 VDC) flow will be equivalent to the AE/BE curves: current draw will be about 1/3 of the AE motor values

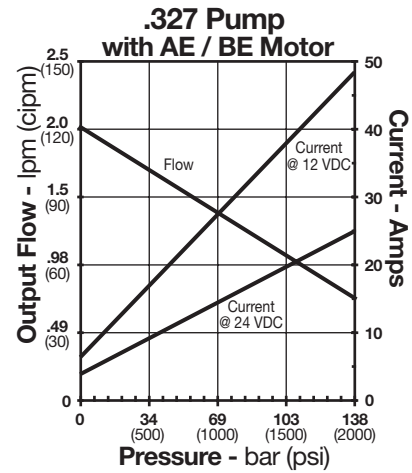
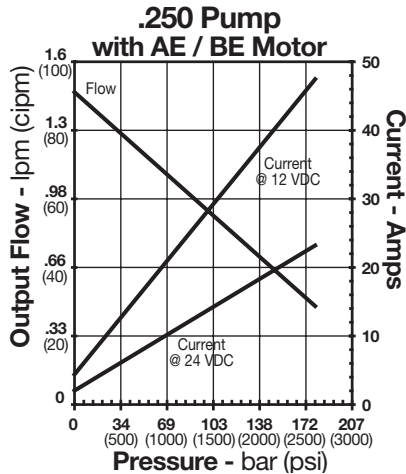
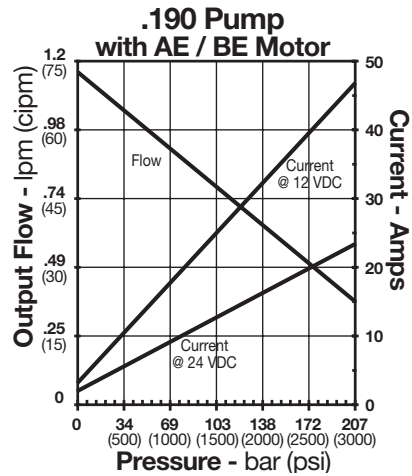
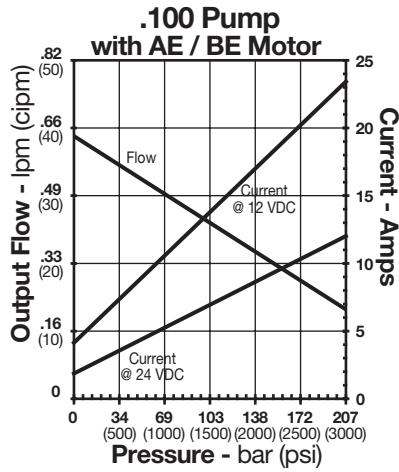

## DC Motor Duty Cycle Characteristics

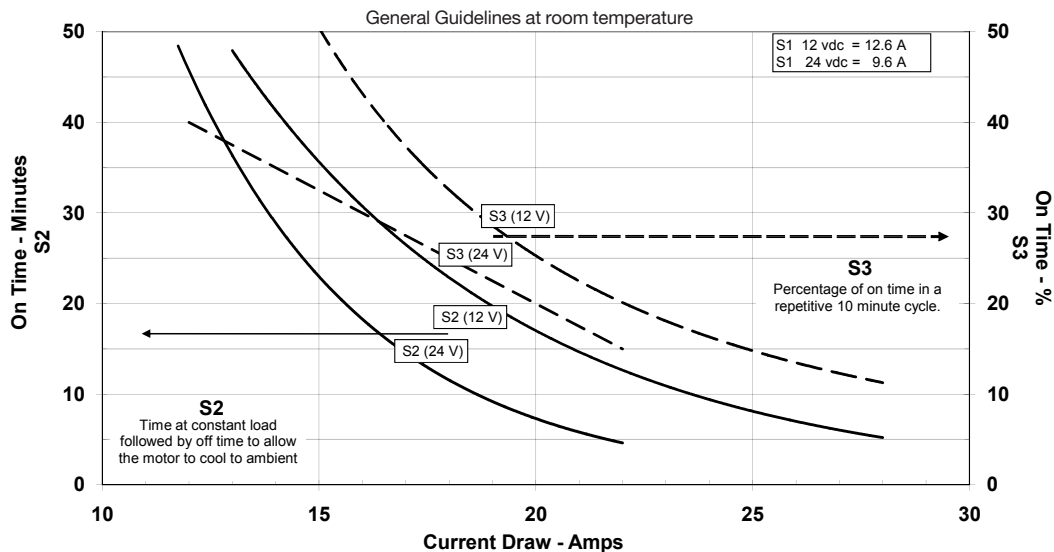

# Performance Data

## 108/118 Series: Series Wound Motors - AM/BI

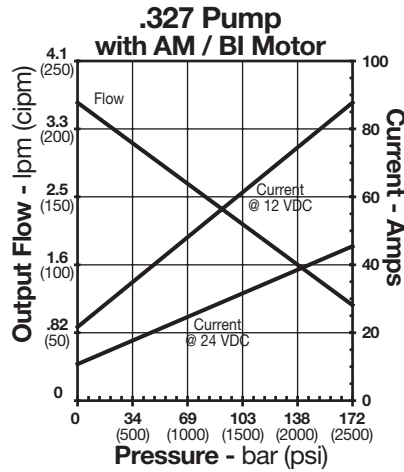
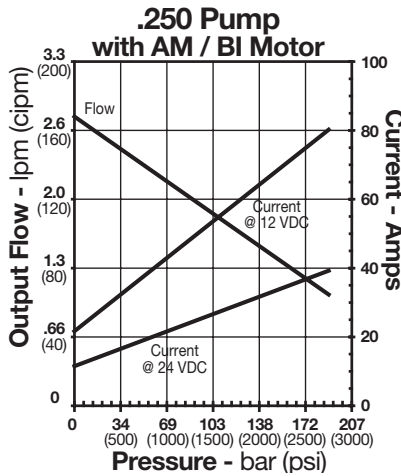
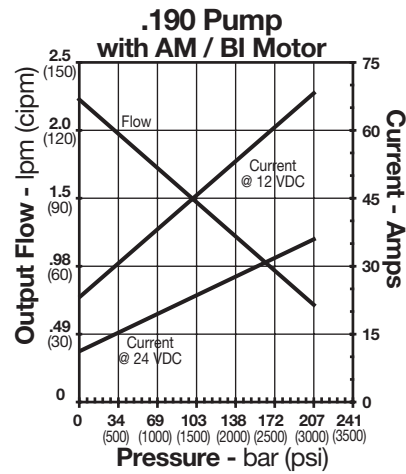
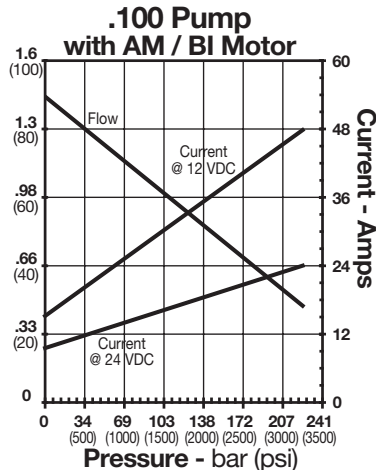

## DC Motor Duty Cycle Characteristics Series Wound Motors - AM/BI

Current Draw vs On Time General Guidelines at room temperature  
Current Draw vs On Time General Guidelines at 21°C (70°F)

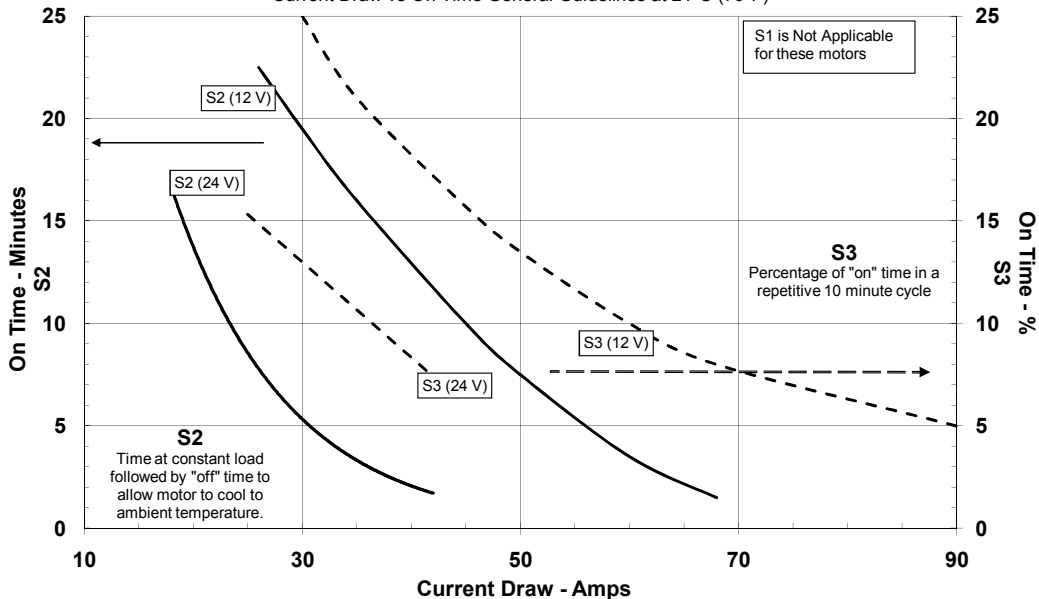

# Performance Data

## 108/118 Series: AC Motors - HA/HD

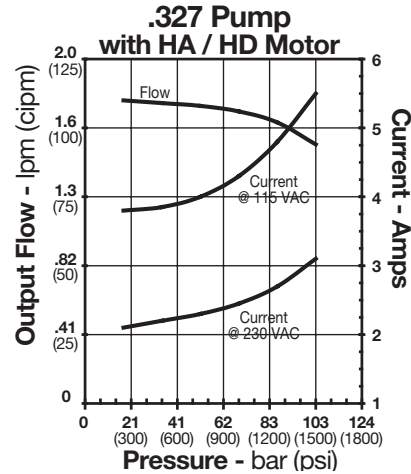
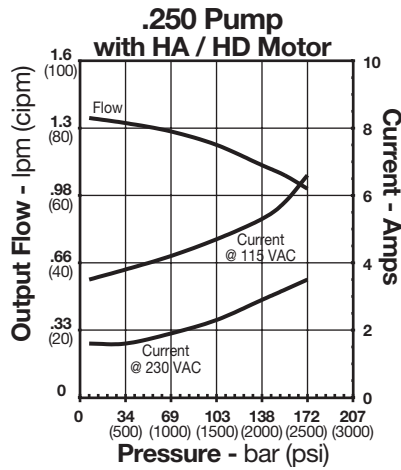
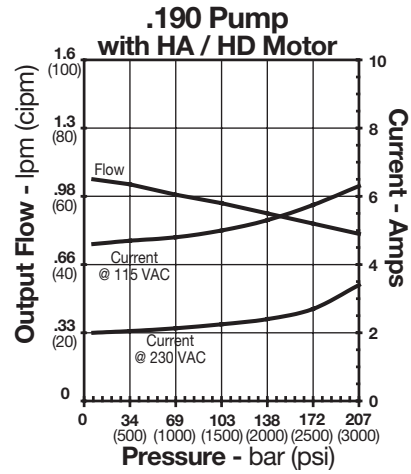
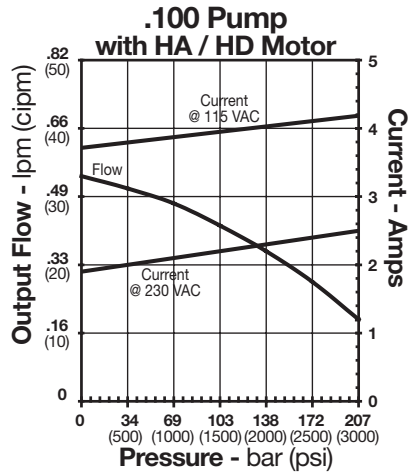

NOTE: S2 = 5

Maximum recommended ON time for the HA/HD motors is 5 minutes, after which the motors must be OFF until cooled to ambient temperature

# Performance Data

**165/175 Series: Permanent Magnet Motors - AY**  
 Note: BY motor (24 VDC) flow will be equivalent to the AY curves;  
 current draw will be about 1/2 of the AY motor values.

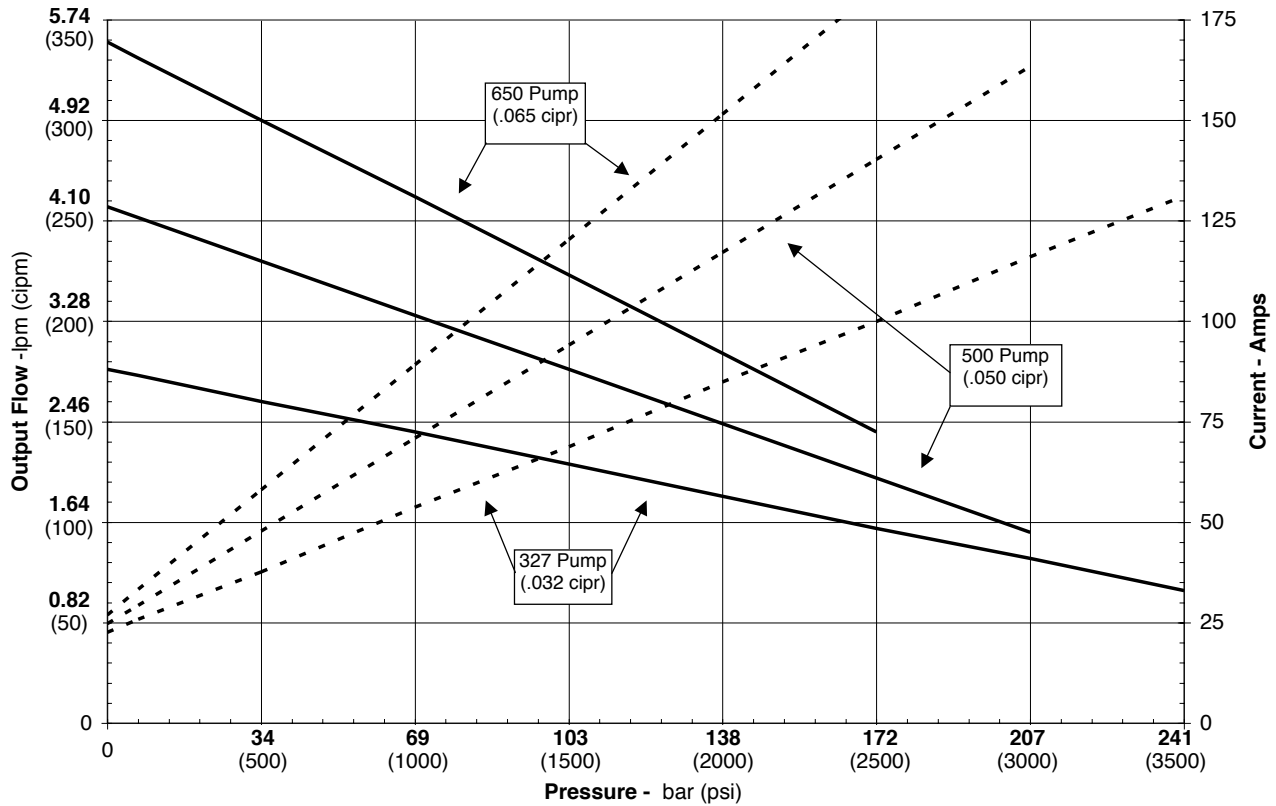

## DC Motor Duty Cycle Characteristics

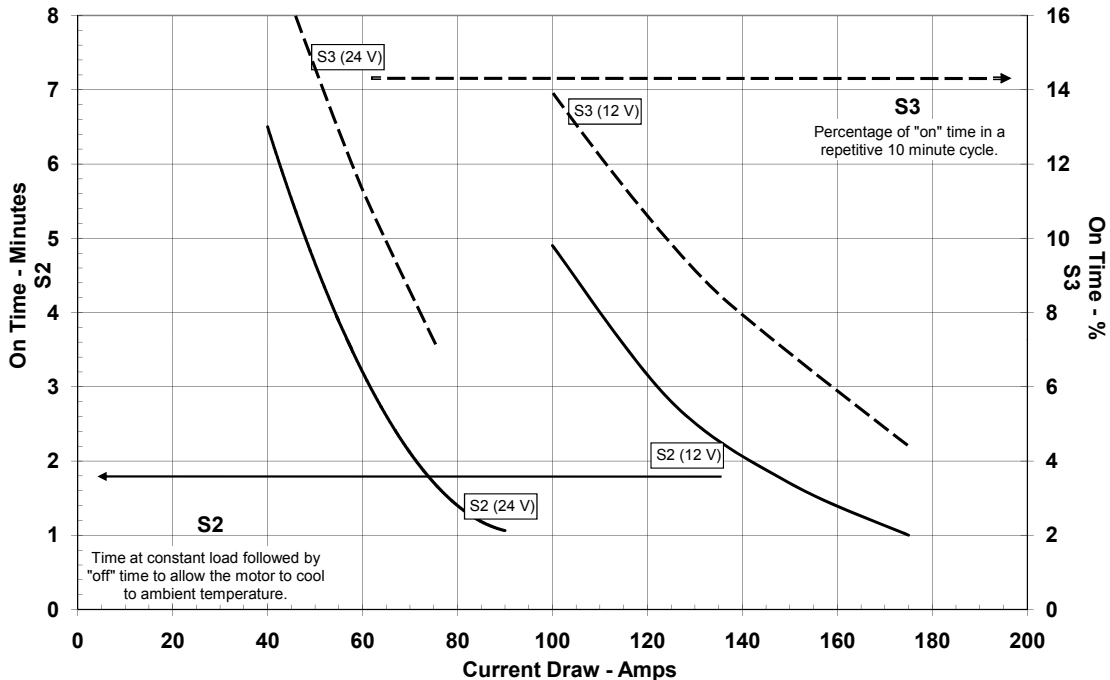

**Standard Product Model Codes**

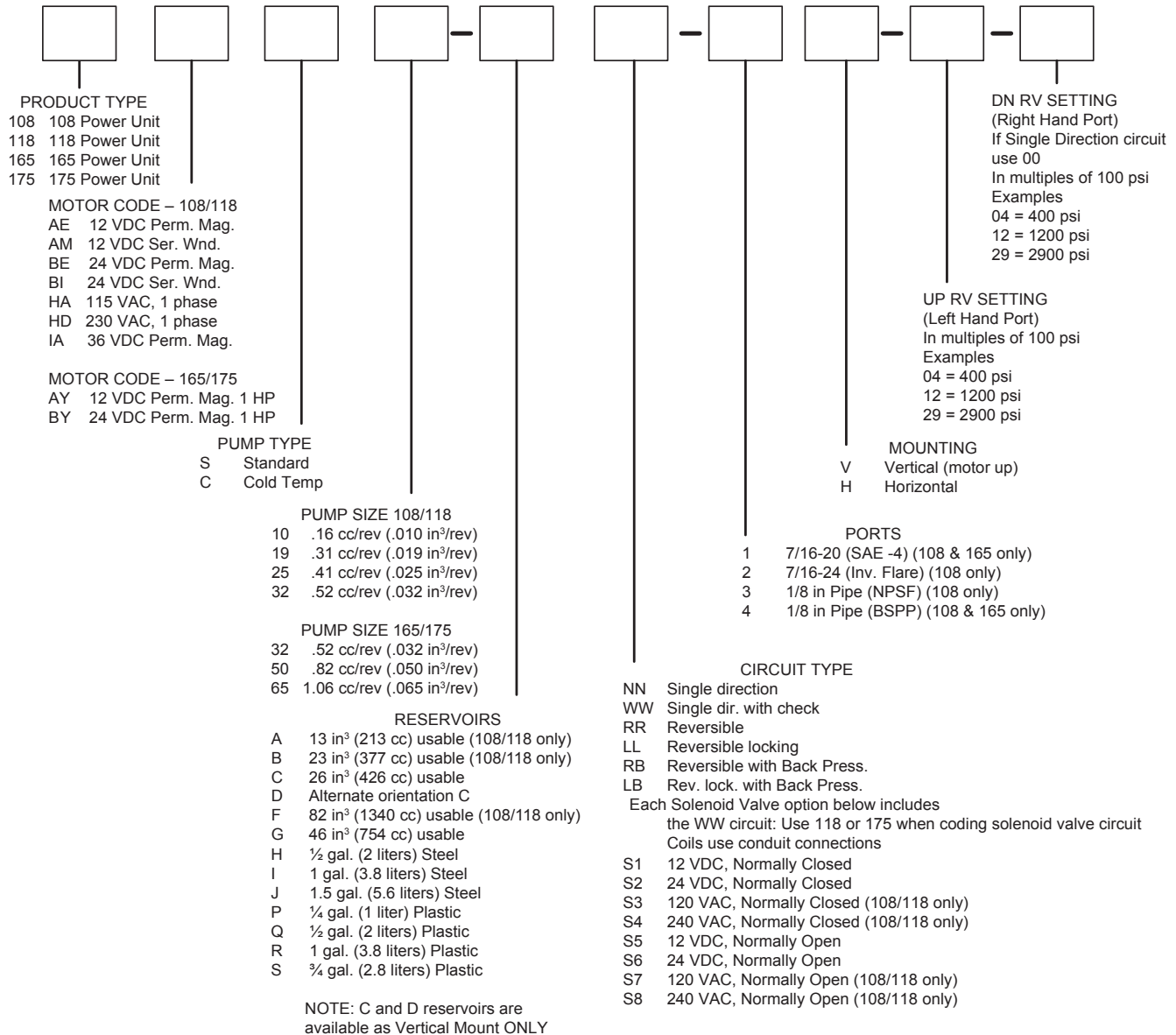

RELIEF VALVE TOLERANCES	
Pressure Range - Bar (PSI)	Tolerance - Bar (PSI)
14 – 34.4 bar (200 – 499 psi)	+/- 5.2 bar (+/- 75 psi)
35.5 – 68.9 bar (500 – 999 psi)	+/- 6.9 bar (+/- 100 psi)
70 – 137.9 bar (1000 – 1999 psi)	+/- 10.3 bar (+/- 150 psi)
138+ bar (2000+ psi)	+/- 13.8 bar (+/- 200 psi)

Remove the 'A' reservoir screw using an 8 mm (5/16 in) socket head wrench/nut driver. Retain the screw/o-ring for reassembly.



'A' reservoir screw

Remove the 'B' reservoir screw using a 4 mm (5/32 in) hex key. Retain the screw for reassembly. It is recommended that the bonded washer/rubber seal is replaced. It is Parker Oildyne part number 415067.



'B' reservoir screw

The 'C', 'D', 'P', 'Q', 'R' and 'S' reservoirs are held to the power unit by four Phillips-head screws. Remove the oil from the tank using a siphon through the reservoir filler port. Remove the four screws and separate the reservoir from the power unit. Retain the screws for reassembly.

The 'F' and 'G' reservoirs are held to the power unit by two screws located in the welded mounting 'ears' of the reservoirs. Remove the oil from the tank using a siphon through the reservoir filler port. Remove the 'F' and 'G' reservoir screw using an 8 mm (5/16 in) socket head wrench/nut driver. Keep the two plastic spacers positioned between the power unit adapter and reservoir 'ears'. They will be needed for reassembly. Retain the screws and the reservoir seal for reassembly also.

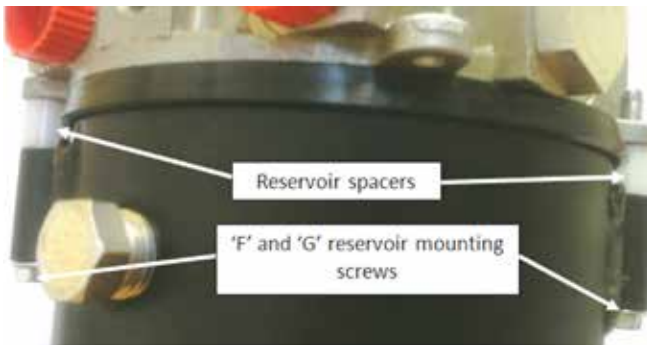

The 'H', 'I' and 'J' reservoirs use an adapter plate between the power unit adapter and the larger reservoir flange. Remove the oil from the tank using a siphon through the reservoir filler port. Remove the four screws holding the reservoir flange to the adapter plate using an 8 mm (5/16 in) socket head wrench/nut driver. Keep the screws for reassembly.

Inspect the suction screen – one for single direction power units, two for reversible circuits. If any screen is damaged or in any way plugged up, it should be replaced. In vertically mounted configurations, the strainer is pressed onto the pump suction leg. With a pair of pliers clamped on the strainer's aluminum ring, gently pull the strainer off of the pipe. If necessary, twisting the pliers will help remove the strainer. In horizontally mounted configurations, the suction strainer is

usually installed over an o-ring of the suction elbow. Again, using a pair of pliers clamped on the strainer's aluminum ring gently pull the strainer from the elbow.

### Suction Screen Installation

#### Vertical mount reservoirs:

Insert the suction screen into a 16 mm (5/8 in) socket. Using a hammer, tap the socket and strainer onto the pump suction leg so that it is secure on the pump leg, but before the bottom of the suction leg touches the strainer screen itself. **NOTE: If the suction leg end is touching the screen itself, the useful screening area of the strainer is greatly reduced.**



#### Horizontal mount reservoirs:

Using fingers only, grasp the aluminum ring of the strainer and push the strainer onto, and over the o-ring on the elbow. When the strainer is properly installed the o-ring on the elbow will retain it.



### Reservoir reinstallation

#### 'A' reservoir

Invert the power unit so the motor end is down. Ensure the rubber seal is in place in the power unit adapter pilot, against which the reservoir will mount. Insert the reservoir screw/o-ring through the hole in the reservoir end. The pump's mounting leg will be very close to the reservoir end. Align the screw with pump's mounting leg threaded hole. **This is a self tapping screw so following these instructions is critical to ensure a proper installation.** Failure to ensure the screw thread and pump mounting thread are aligned can cause a new thread to be formed or cross-threading. Either outcome will not provide an adequate tightness. Turn the screw counter-clockwise in the pump's mounting leg hole thread, until an audible 'click' is heard and felt by the fingers. Only at this point will you turn the screw clockwise to begin tightening the screw into the pump mounting leg. Tighten to a torque of 2.8 +/- .5 Nm (25 +/- 5 in-lbs). Follow the complete mounting, filling, bleeding and startup instructions on page 15.

#### 'B' reservoir

Invert the power unit so the motor end is down. Ensure the rubber seal is in place in the power unit adapter pilot, against which the reservoir will mount. Insert the reservoir screw and new bonded washer/rubber seal (with the seal end facing the



tank), through the hole in the reservoir end. With the screw vertical, locating the pump's mounting leg will take some effort. Once the pump leg is found, turn the screw counter-clockwise until an audible 'click' is heard and felt by the fingers. At this point turn the screw clockwise to begin tightening the screw into the pump mounting leg. Tighten to a torque of 1.9 +/- .3 Nm (17 +/- 3 in-lbs). Follow the complete mounting, filling, bleeding and startup instructions on page 15.

#### 'C', 'D', 'P', 'Q', 'R' and 'S' reservoirs

Ensure the reservoir seal is in place in the power unit adapter pilot. With the reservoir sitting upright on a flat surface, orient the power unit adapter to correctly align with the 'tabs' on the power unit adapter with the brass inserts by the reservoir opening. Push the power unit gently down onto the reservoir to engage the reservoir seal. Once the power unit is firmly on the reservoir, reinstall the four Phillips-head screws through the power unit adapter 'tabs' into the reservoir brass inserts and tighten to 2.8 +/- .5 Nm (25 +/- 5 in-lbs). Follow the complete mounting, filling, bleeding and startup instructions on page 15.

#### 'F' and 'G' reservoirs

With the reservoir vertical, ensure the 'V-lip' seal is in place on the reservoir mouth. The reservoir wall is positioned inside the 'V'. Orient the power unit over the reservoir so the reservoir filler/breather is on the same side as the ports surface of the power unit adapter. The 'tab' on the power unit adapter to the left of the UP port should align with the welded reservoir 'ear'. Insert the screws from the underside of the 'ears' up toward the power unit, ensuring the plastic spacers are in place between the reservoir 'ears' and the power unit adapter 'tabs'. **These are self tapping screws so following these instructions is critical to ensure a proper installation.** When the screw touches the power unit adapter 'tab', turn the screw slowly counter-clockwise (when viewed from the screw head) until an audible 'click' is heard and felt, confirming the screw thread is properly engaged with the power unit 'tab' threaded hole. Then turn the screw in the opposite direction to tighten the screw. Torque both screws to 2.8 +/- .5 Nm (25 +/- 5 in-lbs). Follow the complete mounting, filling, bleeding and startup instructions on page 15.

#### 'H', 'I' and 'J' reservoirs

Ensure the o-ring is in place in the groove of the reservoir adapter plate. Position the reservoir so the filler/breather is aligned between the power unit's UP and DN ports. Gently push the reservoir into the reservoir adapter plate until the reservoir is snug against the plate. Install the four screws from the reservoir end into the reservoir flange holes into the brass inserts of the reservoir adapter plate. Hand-tighten all four screws then alternately tighten each screw to 2.2 to 2.8 Nm (20 to 25 in-lbs). Follow the complete mounting, filling, bleeding and startup instructions on page 15.

#### All Reservoirs

Maintain oil level at all times. The oil should be checked after the first 100 hours and verified that the class of oil meets the requirements of the pump being used. Change the oil every 1000 to 2000 hours depending on the application and operation environment.

#### Hydraulic Fluids

The type of fluid must be compatible with the Nitrile (Buna N) seals used on the power unit, and must comply with the recommendations of the manufacturers of the component parts. Acceptable fluids include standard Automatic Transmission Fluid (ATF) and most mineral based hydraulic fluids with viscosities between 32 cSt (150 SSU) and 64 cSt (300 SSU) at 38°C (100°F). For fluids other than these please contact Parker Oildyne with the details. If users wish to use

alternative oil, hydraulic fluid or ATF, they are warned to check that they have the same properties as those recommended.

**Parker Oildyne takes no responsibility if alternatives are used.**

### **Maintenance Suggestions**

1. Never return to the system any fluid which has leaked out.
2. Always keep the supply of fresh fluid covered tightly.
3. Use clean containers, hoses, and funnels when filling the reservoir. Using a filter cart when adding oil is highly recommended.
4. Use common sense precautions to prevent entry of dirt into components that have been temporarily removed from the circuit.
5. Make sure that all filler/breathers on the reservoir are properly fastened.
6. Do not run the system unless all normally provided suction strainers are in place.
7. Make certain that the fluid used in the system is of a type recommended by the manufacturers of the system or components.
8. Parker Hannifin offers an oil sampling kit which can be used to ascertain the condition of the system fluid.

### **Check Oil Samples Periodically**

Checking oil temperature periodically is good preventive maintenance. Periodically siphon an oil sample from the reservoir and compare it with a sample of clean, new oil.

Oil that has been running too hot will look darker and feel thinner than new oil. It will also smell burned. Normally it will contain more contaminants, because hot oil leads to accelerated wear of component parts.

### **Recommended Spare Parts**

- Suction strainer, Parker Oildyne part number 410521.
- 'A' reservoir mounting screw, Parker Oildyne part number 411355; screw o-ring part, number 409815.
- 'B' reservoir mounting screw – is power unit specific – please contact Parker Oildyne with the power unit 6-digit part number.
- 'C', 'D', 'P', 'Q', 'R' and 'S' reservoirs mounting screw, Parker Oildyne part number 415222.
- 'F' and 'G' reservoir mounting screw, Parker Oildyne part number 415020; plastic spacer, part number 412051.
- 'H', 'I' and 'J' reservoir mounting screw, Parker Oildyne part number 415939.

For any other requirements please contact Parker Oildyne with the 6-digit part number of your power unit. This number is located on the power unit Parker Oildyne label.

Be aware of risk of hazards if poor quality replacement parts are used or are obtained from an unauthorized source.

### **Troubleshooting**

Personnel involved with maintaining these units are advised to wear gloves and protective clothing.

See pages 24 and 25 for troubleshooting help.

### **Conclusive Unit Failure**

If the operation of the unit cannot be restored after attempts at the trouble shooting suggestions listed previously, please contact your local distributor or the Parker Oildyne directly to arrange for warranty replacement/repair if within the warranty period.

FAILURE MODE	CAUSE(S)	CORRECTIVE ACTION
<b>Motor doesn't run</b>	Not wired properly	Follow wiring schematics
	Faulty on/off switch	Replace switch
	Power source is dead	Check fuse
		Turn on power supply
		Replace with good battery
	Dead spot in motor	If all above are ruled out, replace motor
Faulty motor	Replace motor	
<b>Motor runs backward</b>	Wired incorrectly	Follow wiring schematics
	Switch in wrong position	Change switch position
<b>Motor runs too fast</b>	Input voltage is too high	Check power supply for correct voltage
	Nothing is wrong – Series Wound motor is a high speed motor (when under no load)	Applies to 108 Series only
<b>Motor runs too slow</b>	Input voltage is too low	Check power supply for correct voltage
	Pump is running against a load	Ensure test valves are open (unrestricted)
<b>Amp draw is too high</b>	Incorrect motor input voltage	Verify correct voltage is used
<b>Motor stalls out or quits</b>	Fuse blown	Ensure correct fuse size is used
	Motor thermal breaker kicked off	Allow motor to cool, shorten duty cycle
	Motor incorrectly wired	Check wiring per drawing
<b>Pump flow low</b>	Motor turning too slow	Ensure correct input voltage
	Solenoid valve is open	Ensure valve is closed
<b>Pump flow too high</b>	Motor running too fast	Ensure correct input voltage
<b>No flow</b>	Motor isn't running	Ensure motor is connected and power is on
	Air in the pump – not primed	Follow startup instructions for bleeding
	Oil level in tank too low	Fill tank to proper level
	Solenoid valve is open	Ensure valve is closed
<b>Won't build pressure</b>	No load valve in circuit	Apply resistance to flow in circuit
	Oil temperature too high/viscosity too low	Check oil temperature, cool as necessary, ensure oil is thick enough for application conditions
	Motor or voltage is incorrect	Ensure motor and voltage are right
	Solenoid valve is open	Ensure solenoid valve is closed



FAILURE MODE	CAUSE(S)	CORRECTIVE ACTION
<b>Pressure decays rapidly</b>	Fittings not tightened	Check hoses and fittings for leaks
	Solenoid valve opened	Check solenoid for proper operation
	No check valves installed	Verify ordering code includes checks
<b>Pressure decays slowly</b>	Fittings not tightened	Tighten all fittings
<b>Won't release opposite check</b>	Pilot check ratio exceeded	Maintain a high pressure to low pressure RV ratio of no more than 5:1
<b>Chatters on operation</b>	Over-running load condition	Install counterbalance valve
<b>Tank overflows during retract</b>	Tank was overfilled when cylinder was extended	Remove some oil from tank
<b>Pump runs dry</b>	Reservoir too small	Install correctly sized reservoir
	Oil level in tank too low	Add oil to reservoir
<b>Leaks at port</b>	Fitting is cross-threaded	If not damaged, reinstall fitting
	Fitting isn't tight	Tighten to fitting torque spec
	Fitting o-ring damaged	Replace o-ring or fitting
	Incorrect fitting type	Examine adapter threads for damage. If none, install correct fitting type
<b>Motor loose</b>	Motor mounting screws loose	Tighten to proper torque
<b>Back pressure circuit not working</b>	Connections to cylinder(s) not made correctly	Ensure 'UP' port is connected to Piston End of cylinder(s)
<b>Reservoir leaks</b>	Tank is overfilled	Remove some fluid
	O-ring seal at adapter is missing	Install new reservoir seal
	O-ring seal at adapter is damaged	Install new reservoir seal
	Reservoir mount screw is loose	Torque screw to spec
	Not properly mounted	Check for incorrect mounting
<b>Solenoid not releasing</b>	Coil not energized (if N.C.)	Apply proper voltage to coil
	Coil not de-energized (if N.O.)	De-energize coil



**EC Declaration of Incorporation.**

**Manufacturer's Name:** Parker Hannifin Corporation  
**Manufacturer's Address:** Oildyne Division  
 5520 Highway 169 North  
 New Hope, MN 55428 USA

Declare that the partially complete machinery described below conforms to applicable health and safety requirements of Part 1 of Annex I of Machinery Directive 2006/42/EC taking full account of requirements for pressure equipment. This partly completed machinery must not be put into service until the machinery into which it is to be incorporated has been declared in conformity with the provisions of the Machinery Directive. Confidential technical documentation has been compiled as described in Part B of Annex VII of Machinery Directive 2006/42/EC and is available to European national authorities on written request. If a request is received documentation will be transmitted either electronically or by post.

**Description:** Oildyne 108/118 & 165/175 Series Power Units  
**Model Number:** As Applies  
**Sizes:** All  
**Serial Number:** All

The following standards have either been referred to or complied with in part or in full as relevant:

ENISO 12100 – 2	Machinery Safety	-	Basic concepts, general principles for design – Part 2: Technical principles and specifications.
EN13849	Machinery Safety	-	Safety Related Parts of Control Systems – Part 1: General Principles for Design.
EN 982:1996	Machinery Safety	-	Safety requirements for fluid power systems and their components – Hydraulics.

**Full Name of responsible person** Van Mancuso

**Place of signing:**

Parker Hannifin Corporation  
 Oildyne Division  
 5520 Highway 169 North  
 New Hope, MN 55428 USA

**Position** General Manager, Oildyne Division

**Signature** 

**Date** March 17, 2011

**Full Name of Authorized European Representative** Stephen Fryer

**Place of signing:**

Parker Hannifin Ltd.  
 Cylinder Division Europe  
 6 Greycaine Road,  
 Watford, Hertfordshire. WD24 7QA, UK

**Position** General Manager, Cylinder Division Europe

**Signature** 

**Date** March 17, 2011

# Parker Worldwide

**AE – UAE, Dubai**

Tel: +971 4 8127100  
parker.me@parker.com

**AR – Argentina, Buenos Aires**

Tel: +54 3327 44 4129

**AT – Austria, Wiener Neustadt**

Tel: +43 (0)2622 23501-0  
parker.austria@parker.com

**AT – Eastern Europe, Wiener Neustadt**

Tel: +43 (0)2622 23501 900  
parker.easteurope@parker.com

**AU – Australia, Castle Hill**

Tel: +61 (0)2-9634 7777

**AZ – Azerbaijan, Baku**

Tel: +994 50 2233 458  
parker.azerbaijan@parker.com

**BE/LU – Belgium, Nivelles**

Tel: +32 (0)67 280 900  
parker.belgium@parker.com

**BR – Brazil, Cachoeirinha RS**

Tel: +55 51 3470 9144

**BY – Belarus, Minsk**

Tel: +375 17 209 9399  
parker.belarus@parker.com

**CA – Canada, Milton, Ontario**

Tel: +1 905 693 3000

**CH – Switzerland, Etoy**

Tel: +41 (0) 21 821 02 30  
parker.switzerland@parker.com

**CL – Chile, Santiago**

Tel: +56 2 623 1216

**CN – China, Shanghai**

Tel: +86 21 2899 5000

**CZ – Czech Republic, Klecany**

Tel: +420 284 083 111  
parker.czechrepublic@parker.com

**DE – Germany, Kaarst**

Tel: +49 (0)2131 4016 0  
parker.germany@parker.com

**DK – Denmark, Ballerup**

Tel: +45 43 56 04 00  
parker.denmark@parker.com

**ES – Spain, Madrid**

Tel: +34 902 330 001  
parker.spain@parker.com

**FI – Finland, Vantaa**

Tel: +358 (0)20 753 2500  
parker.finland@parker.com

**FR – France, Contamine s/Arve**

Tel: +33 (0)4 50 25 80 25  
parker.france@parker.com

**GR – Greece, Athens**

Tel: +30 210 933 6450  
parker.greece@parker.com

**HK – Hong Kong**

Tel: +852 2428 8008

**HU – Hungary, Budapest**

Tel: +36 1 220 4155  
parker.hungary@parker.com

**IE – Ireland, Dublin**

Tel: +353 (0)1 466 6370  
parker.ireland@parker.com

**IN – India, Mumbai**

Tel: +91 22 6513 7081-85

**IT – Italy, Corsico (MI)**

Tel: +39 02 45 19 21  
parker.italy@parker.com

**JP – Japan, Fujisawa**

Tel: +(81) 4 6635 3050

**KR – South Korea, Seoul**

Tel: +82 2 559 0400

**KZ – Kazakhstan, Almaty**

Tel: +7 7272 505 800  
parker.easteurope@parker.com

**LV – Latvia, Riga**

Tel: +371 6 745 2601  
parker.latvia@parker.com

**MX – Mexico, Apodaca**

Tel: +52 81 8156 6000

**MY – Malaysia, Shah Alam**

Tel: +60 3 7849 0800

**NL – The Netherlands, Oldenzaal**

Tel: +31 (0)541 585 000  
parker.nl@parker.com

**NO – Norway, Asker**

Tel: +47 66 75 34 00  
parker.norway@parker.com

**NZ – New Zealand, Mt Wellington**

Tel: +64 9 574 1744

**PL – Poland, Warsaw**

Tel: +48 (0)22 573 24 00  
parker.poland@parker.com

**PT – Portugal, Leca da Palmeira**

Tel: +351 22 999 7360  
parker.portugal@parker.com

**RO – Romania, Bucharest**

Tel: +40 21 252 1382  
parker.romania@parker.com

**RU – Russia, Moscow**

Tel: +7 495 645-2156  
parker.russia@parker.com

**SE – Sweden, Spånga**

Tel: +46 (0)8 59 79 50 00  
parker.sweden@parker.com

**SG – Singapore**

Tel: +65 6887 6300

**SK – Slovakia, Banská Bystrica**

Tel: +421 484 162 252  
parker.slovakia@parker.com

**SL – Slovenia, Novo Mesto**

Tel: +386 7 337 6650  
parker.slovenia@parker.com

**TH – Thailand, Bangkok**

Tel: +662 717 8140

**TR – Turkey, Istanbul**

Tel: +90 216 4997081  
parker.turkey@parker.com

**TW – Taiwan, Taipei**

Tel: +886 2 2298 8987

**UA – Ukraine, Kiev**

Tel +380 44 494 2731  
parker.ukraine@parker.com

**UK – United Kingdom, Warwick**

Tel: +44 (0)1926 317 878  
parker.uk@parker.com

**US – USA, Cleveland (industrial)**

Tel: +1 216 896 3000

**US – USA, Lincolnshire (mobile)**

Tel: +1 847 821 1500

**VE – Venezuela, Caracas**

Tel: +58 212 238 5422

**ZA – South Africa, Kempton Park**

Tel: +27 (0)11 961 0700  
parker.southafrica@parker.com

**US Product Information Centre**

Free phone: 1-800-272-7537

**European Product Information Centre**

Free phone: 00 800 27 27 5374  
www.parker.com

**Parker Hannifin Corporation**

Hydraulic Pump and Power Systems Division  
Oildyne Business Unit  
5520 Highway 169 North  
New Hope, MN 55428 USA  
Ph: 937-644-3915  
Fax: 937-642-3738  
www.parker.com/hps

