

Solenoid directional valves type DPHI and DPHE

two stage, ISO 4401 size 10, 16, 25 and 32

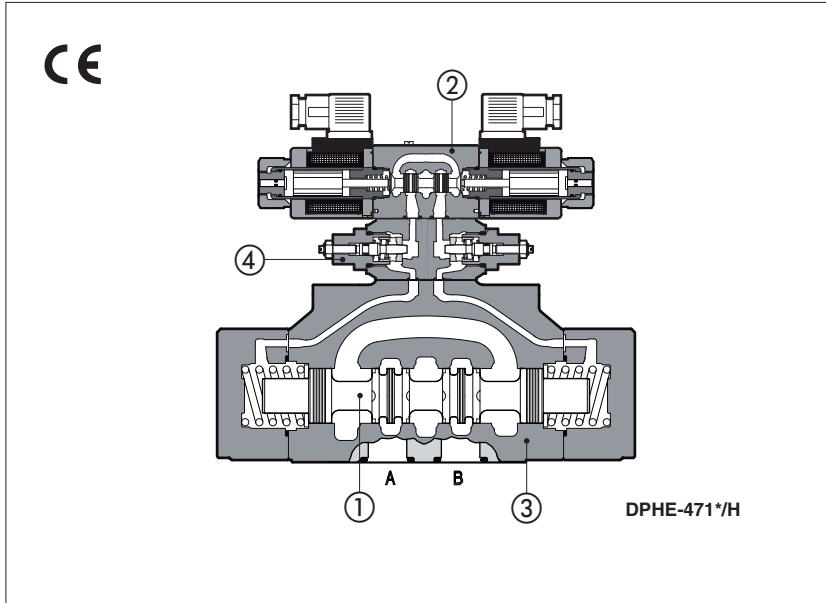

Spool type, two stage directional valves with solenoids certified according to North American standard **cURus**, available in two different executions:

- DPHI for AC and DC supply, solenoid pilot ① type DHI, see tech. table E010
- DPHE high performances, for AC and DC supply, solenoid pilot ① type DHE see tech. table E015

Single and double solenoids versions are available in two or three position configurations and with a wide range of interchangeable spools ②, see section ②. Standard coils protection **IP65** and they are easily replaceable without tools.

The valve body is made by shell-moulding casting ③ with wide internal passages.

The valves can be supplied with optional devices, see section ④ for available options.

Surface mounting: ISO 4401, size 10, 16, 25 and 32

Max flow up to 160, 300, 700, 1000 l/min. Pressure up to 350 bar

1 MODEL CODE

DPH	I	-	2	71	1	/A	-	X	24DC	**	/*
Two stage directional control valve	Solenoid pilot valve: I = DHI for AC and DC supply with cURus certified solenoids E = DHE for AC and DC supply, high performances with cURus certified solenoids		Valve size: 1 = 10 2 = 16 4 = 25 6 = 32	Valve configuration, see section ②: 61 = single solenoid, center plus external position, spring centered 63 = single solenoid, 2 external positions, spring offset 67 = single solenoid, center plus external position, spring offset 70 = double solenoid, 2 external positions, without springs 71 = double solenoid, 3 positions, spring centered 75 = double solenoid, 2 external positions, with detent Other configurations are available on request				X = without connector See section ⑤ for available connectors, to be ordered separately 00 = solenoid valve without coils (for DPHI) 00-AC = AC solenoid valve without coils (for DPHE) 00-DC = DC solenoid valve without coils (for DPHE)		Series number	Seals material: omit for NBR (mineral oil & water glycol) PE = FPM
Voltage code, see section ⑥											
Options, see section ④											
Spool type, see section ②											

2 CONFIGURATIONS and SPOOLS (representation according to ISO 1219-1, for functional scheme, see section ④)

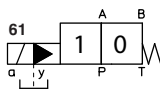
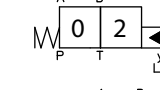
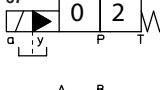
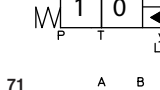
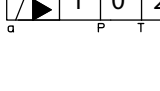
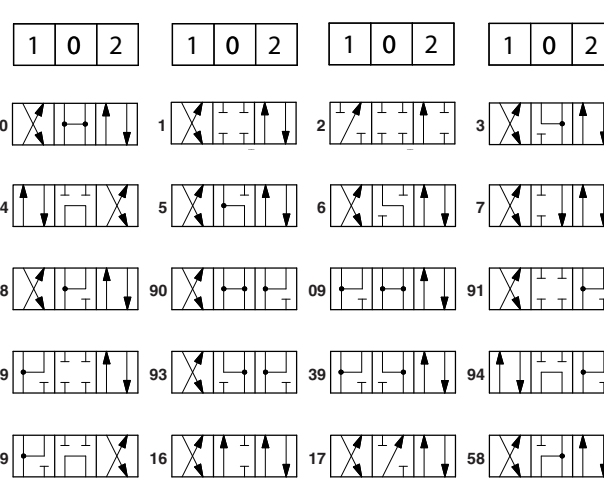
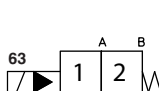
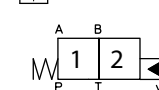
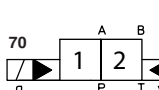
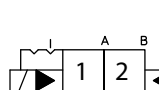
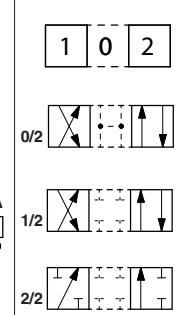
Configurations	Spoils	Configurations	Spoils
    		   	
<p>NOTES (see also section 4.2 for special shaped spools):</p> <ul style="list-style-type: none"> - For DP*-1 are available only spools: 0, 0/2, 1, 1/2, 3, 4, 5, 58, 6, 7 - For DP*-6 are available only spools: 0, 1, 1/2, 2, 3, 4, 5, 58, 6, 7, 8, 19, 91 			

3 MAIN CHARACTERISTICS OF SOLENOID DIRECTIONAL VALVES TYPE DPHI, DPHE and DPHER

Installation position	Any position for all valves except for type -*70 (without springs) that must be installed with horizontal axis if operated by impulses.
Subplate surface finishing	Roughness index Ra 0,4 - flatness ratio 0,01/100 (ISO 1101)
MTTFd values according to EN ISO 13849	150 years, for further details see technical table P007
Ambient temperature	from -30°C to +70°C (standard seals) -20°C to +70°C (/PE seals) (1)
Fluid	Hydraulic mineral oil HL, HLP as per DIN 51524
Recommended viscosity	15 ÷ 100 mm ² /s - max allowed range 2,8 ÷ 500 mm ² /s
Fluid contamination class	ISO 4406 class 21/19/16 NAS 1638 class 10, in line filters of 25 µm (β ₂₅ ≥ 75 recommended)
Fluid temperature	-30°C +60°C (standard seals) -20°C +80°C (/PE seals)
Flow direction	As shown in the symbols of tables 2
Operating pressure	P, A, B, X = 350 bar T = 250 bar for external drain (standard) T and Y with internal drain (option /D) = 120 bar DPHI; 210 bar DPHE (DC); 160 bar DPHE (AC) Ports Y and L (if required): 0 bar Minimum pilot pressure for correct operation is 8 bar
Rated flow	See diagrams Q/Δp at section 6
Maximum flow	DPH*-1: 160 l/min ; DPH*-2: 300 l/min ; DPH*-4: 700 l/min ; DPH*-6: 1000 l/min (see rated flow at section 6 and operating limits at section 7)

(1) Option /BT = special version for ambient temperature -40°C +60°C available on request

3.1 Coils characteristics

Insulation class	H (180°C) for DC coils (all versions) and AC coils (only DPHI) F (155°C) for AC coils (only DPHE) Due to the occurring surface temperatures of the solenoid coils, the European standards EN ISO 13732-1 and EN ISO 4413 must be taken into account
Protection degree to DIN EN 60529	IP 65 (with connectors 666, 667, 669 or E-SD correctly assembled)
Relative duty factor	100%
Supply voltage and frequency	See electric feature 5
Supply voltage tolerance	± 10%
Certification	cURus North American standard

4 NOTES

4.1 Options

/A = Solenoid mounted at side of port A of main body (only for single solenoid valves).
In standard version, solenoid is mounted at side of port B.

/D = Internal drain (standard configuration is external drain)

/E = External pilot pressure (standard configuration is internal pilot pressure).

/FV = With proximity switch for spool position monitoring: see tab. E110.

/R = Pilot pressure generator (4 bar on port P - not for DPH*-1, see section 9).

/S = Main spool stroke adjustment (not for DPH*-1).

/WP = Prolonged manual override protected by rubber cap.

⚠ The manual override operation can be possible only if the pressure at T port is lower than 50 bar

Devices for main spool switching control and to reduce the hydraulic shocks at the valve operation

/H = Adjustable chokes (meter-out to the pilot chambers of the main valve).

/H9 = Adjustable chokes (meter-in to the pilot chambers of the main valve).

/L1, /L2, /L3 = calibrated restrictors on A and B ports of the pilot valve: **L1** = 0,8mm, **L2** = 1mm, **L3** = 1,25mm)

/L9 = (only for DP-2 and DP-4) plug with calibrated restrictor in P port of pilot valve - see section 10

FUNCTIONAL SCHEME (config. 71)
example of switching control options

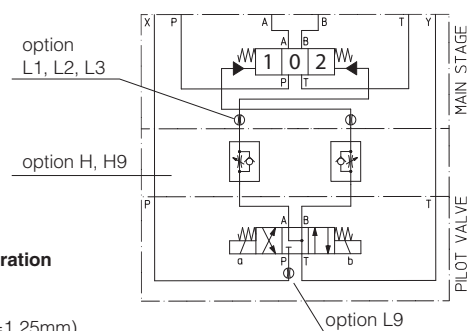

4.2 Special shaped spools

- spools type **0** and **3** are also available as **0/1** and **3/1** with restricted oil passages in central position, from user ports to tank.

- spools type **1, 4, 5, 58, 6** and **7** are also available as **1/1, 4/8, 5/1, 58/1, 6/1** and **7/1** that are properly shaped to reduce water-hammer shocks during the switching (to use with option /L*).

Shaped spool availability	0/1	3/1	1/1	4/8	5/1	58/1	6/1	7/1
DPH*-1	•	•		•				
DPH*-2, DPH*-4	•	•	•	•	•	•	•	•
DPH*-6		•	•	•				

5 ELECTRIC FEATURES

Valve	External supply nominal voltage ± 10%	Voltage code	Type of connector	Power consumption (2)	Code of spare coil		
					DPHI	Colour of coil label DPHI	DPHE
DPHI DPHE	6 DC	6 DC (4)	666 or 667	33 W (DPHI) 30 W (DPHE)	COU-6DC/80	brown	-
	12 DC	12 DC			COU-12DC/80	green	COE-12DC/10
	14 DC	14 DC			COU-14DC/80	brown	COE-14DC/10
	24 DC	24 DC			COU-24DC/80	red	COE-24DC/10
	28 DC	28 DC			COU-28DC/80	silver	COE-28DC/10
	48 DC	48 DC			COU-48DC/80	silver	COE-48DC/10
	110 DC	110 DC			COU-110DC/80	gold	COE-110DC/10
	125 DC	125 DC			COU-125DC/80	blue	COE-125DC/10
	220 DC	220 DC			COU-220DC/80	black	COE-220DC/10
	24/50 AC	24/50/60 AC (4)			COI-24/50/60AC/80 (1)	pink	-
	24/60 AC						
	48/50 AC	48/50/60 AC (4)			COI-48/50/60AC/80 (1)	white	-
	48/60 AC						
	110/50 AC	110/50/60 AC			COI-110/50/60AC/80 (1)	yellow	COE-110/50/60AC/10
115/60 AC (5)				COE-115/60AC/10			
120/60 AC (4)	120/60 AC	COI-120/60AC/80	white	-			
230/50 AC	230/50/60 AC	COI-230/50/60AC/80 (1)	light blue	COE-230/50/60AC/10			
230/60 AC			silver	COER-230/60AC/10			
110/50 AC	110RC	COU-110RC/80	gold	COE-110RC/10			
120/60 AC							
230/50 AC	230RC	COU-230RC/80	blue	COE-230RC/10			
230/60 AC							

(1) Coil can be supplied also with 60 Hz of voltage frequency: in this case the performances are reduced by 10-15% and the power consumption is 55 VA (DPHI) and 58 VA (DPHE)

(2) Average values based on tests performed at nominal hydraulic condition and ambient/coil temperature of 20°C.

(3) When solenoid is energized, the inrush current is approx 3 times the holding current. Inrush current values correspond to a power consumption of about 150 VA.

(4) Only for DPHI (5) Only for DPHE

6 FLOW VERSUS PRESSURE DIAGRAMS Based on mineral oil ISO VG 46 at 50°C

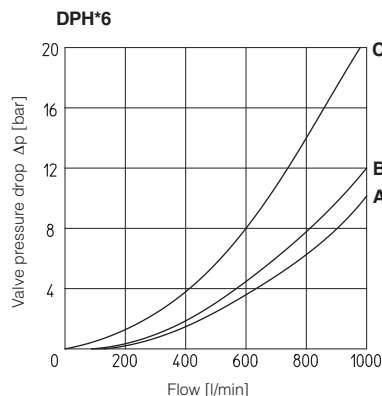
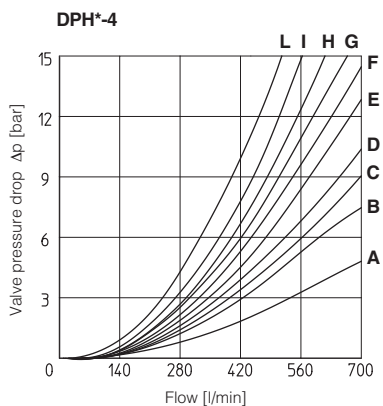
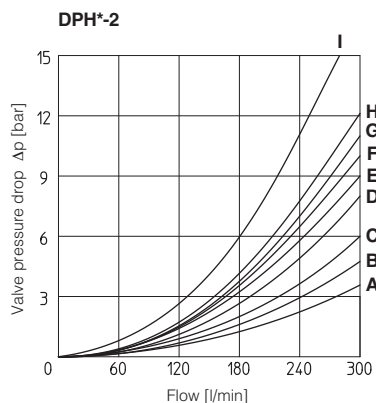
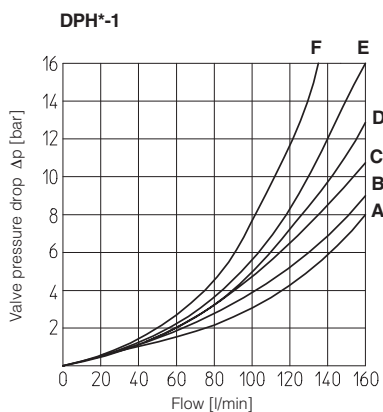

DPH*-1

Spool type	Flow direction				
	P→A	P→B	A→T	B→T	P→T
0/2, 1/2	D	E	D	C	-
0	D	E	C	C	E
1	A	B	D	C	-
3, 6, 7	A	B	C	C	-
4, 4/8	B	C	D	D	-
5, 5/8	A	E	C	C	F

DPH*-2

Spool type	Flow direction				
	P→A	P→B	A→T	B→T	P→T
0/2, 1, 3, 6, 7, 8	A	A	D	A	-
1/1, 1/2, 7/1	B	B	D	E	-
0	A	A	D	E	C
0/1	A	A	-	-	-
2	A	A	-	-	-
2/2	B	B	-	-	-
3/1	A	A	D	D	-
4	C	C	H	I	F
4/8	C	C	G	I	F
5	A	B	F	H	G
5/1	A	B	D	F	-
6/1	B	B	C	E	-
09	A	-	-	G	-
16	A	C	D	F	-
17	C	A	E	F	-
19	C	-	-	G	-
39	C	-	-	H	-
49	-	D	-	-	-
58	B	A	F	H	H
58/1	B	A	D	F	-
90	A	A	E	-	D
91	C	C	E	-	-
93	-	C	D	-	-
94	D	-	-	-	-

DPH*-4

Spool type	Flow direction				
	P→A	P→B	A→T	B→T	P→T
1	B	B	B	D	-
1/1	D	E	E	F	-
1/2	E	D	B	C	-
0	D	C	D	E	F
0/1, 3/1, 5/1, 6, 7	D	D	D	F	-
0/2	D	D	D	E	-
2	B	B	-	-	-
2/2	E	D	-	-	-
3	B	B	D	F	-
4	C	C	H	L	L
5	A	D	D	D	H
6/1	D	E	D	F	-
7/1	D	E	F	F	-
8	D	D	E	F	-
09	D	-	-	F	F
16	C	D	E	F	-
17	E	D	E	F	-
19	F	-	-	E	-
39	G	F	-	F	-
58	E	A	B	F	H
58/1	E	D	D	F	-
90	D	D	D	-	F
91	F	F	D	-	-
93	-	G	D	-	-

DPH*6

Spool type	Flow direction				
	P→A	P→B	A→T	B→T	P→T
0	A	A	B	B	B
1	A	A	A	B	-
3	A	-	A	B	-
4	A	A	C	C	C

7 OPERATING LIMITS For a correct valve operation do not exceed the max recommended flow rates (l/min) shown in the below tables

DPH*-1

Spool	Inlet pressure [bar]			
	70	160	210	350
	Flow rate [l/min]			
0, 1, 3, 6, 7	160	160	160	145
4, 4/8	160	160	135	100
5, 58	160	160	145	110
0/1, 0/2, 1/2	160	160	145	135

DPH*-2

Spool	Inlet pressure [bar]			
	70	140	210	350
	Flow rate [l/min]			
0, 1, 3, 6, 7, 8	300	300	300	300
2, 4, 4/8	300	300	240	140
5	260	220	180	100
0/1, 0/2, 1/2	300	250	210	180
16, 17, 56, *9, 9*	300	300	270	200

DPH*-4

Spool	Inlet pressure [bar]			
	70	140	210	350
	Flow rate [l/min]			
1, 6, 7, 8	700	700	700	600
2, 4, 4/8	500	500	450	400
5, 0/1, 0/2, 1/2	600	520	400	300
0, 3	700	700	600	540
16, 17, 58, *9, 9*	500	500	500	450

DPH*-6

Spool	Inlet pressure [bar]			
	70	140	210	350
	Flow rate [l/min]			
1, 3, 6, 7, 8	1000	950	850	700
0	950	900	800	650
2, 4, 4/8, 5	850	800	700	450
0/1, 58, 19, 91	950	850	650	450

8 SWITCHING TIMES (average values in m sec)

Valve model	Configuration	Switch	Piloting pressure					
			70 bar		140 bar		250 bar	
			Alternating current	Direct current	Alternating current	Direct current	Alternating current	Direct current
DPH*-1	71, 61, 67, 61*/A, 67*/A	Switch ON	35	50	30	45	20	35
		Switch OFF	50					
	63, 63*/A	Switch ON	50	75	40	65	30	50
		Switch OFF	80					
DPH*-2	71, 61, 67, 61*/A, 67*/A	Switch ON	40	55	30	50	20	40
		Switch OFF	60					
	63, 63*/A	Switch ON	55	80	45	70	35	55
		Switch OFF	95					
DPH*-4	71, 61, 67, 61*/A, 67*/A	Switch ON	60	80	45	60	30	45
		Switch OFF	80					
	63, 63*/A	Switch ON	95	115	75	95	50	65
		Switch OFF	130					
DPH*-6	71, 61, 67, 61*/A, 67*/A	Switch ON	70	95	55	70	40	55
		Switch OFF	150					
	63, 63*/A	Switch ON	115	145	95	110	70	90
		Switch OFF	280					

Notes:

- For configuration 70 and 75, times of switching ON and switching OFF are the same: this value is equal to time of switch ON of configuration 63.
- TEST CONDITIONS
 - Nominal voltage supply DC (direct) and AC (alternating) with connector type SP-666. The use of other connectors can affect the switching time;
 - 2 bar of counter pressure on port T;
 - mineral oil: ISO VG 46 at 50°C
- The response time is affected by elasticity of the hydraulic circuit, by variation of hydraulic characteristics and temperature.

9 PILOT PRESSURE GENERATOR (OPTION /R)

The device /R generates an additional pressure drop, in order to ensure the minimum pilot pressure, for correct operation of the valves with internal pilot and fitted with spools type 0, 0/1, 4, 4/8, 5, 58, 09, 90, 94, 49. The device /R has to be fitted when the pressure drop in the valve, verified on flow versus pressure diagrams, is lower than the minimum pilot pressure value.

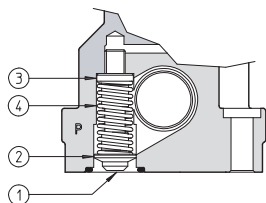

- 1 Flapper-guide
- 2 Flapper
- 3 Spring stop-washer
- 4 Spring

Ordering code of spare pilot pressure generator

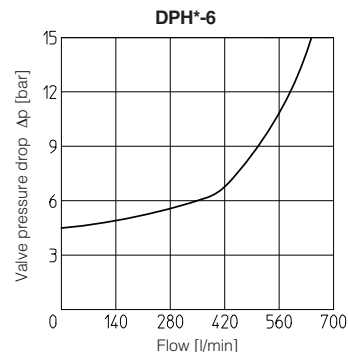
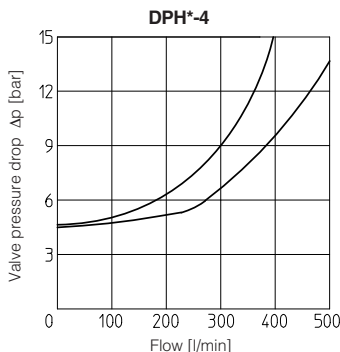
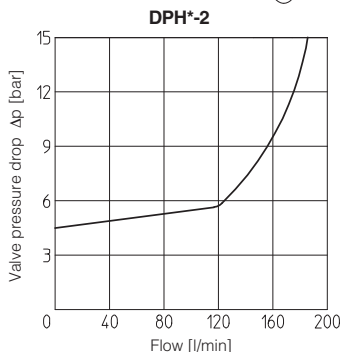
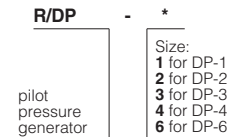

10 PLUGS LOCATION FOR PILOT/DRAIN CHANNELS

Depending on the position of internal plugs, different pilot/drain configurations can be obtained as shown below. To modify the pilot/drain configuration, proper plugs must only be interchanged. The plugs have to be sealed using loctite 270. Standard valves configuration provides internal pilot and external drain

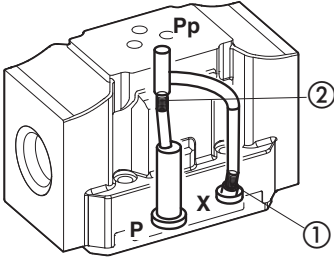
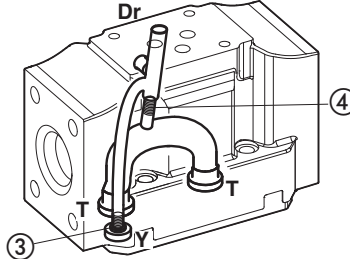
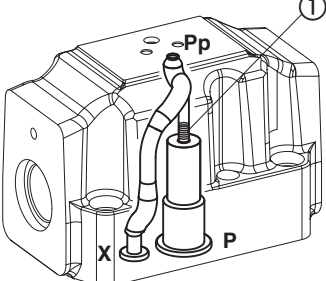
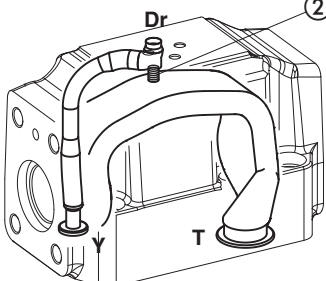
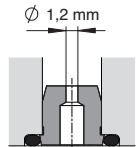
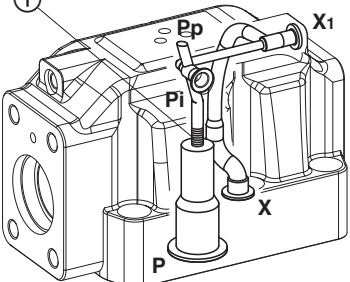
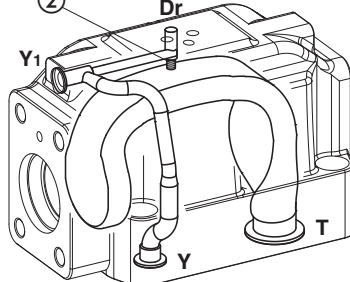
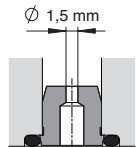
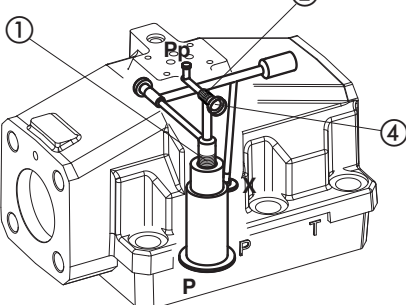
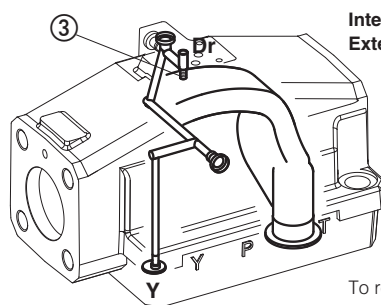
DPH*-1	Pilot channels 	Drain channels 	<p>Internal piloting: blinded plug SP-X300F ① in X; plug SP-X310F ② in Pp;</p> <p>External piloting: blinded plug SP-X300F ② in Pp; plug SP-X310F ① in X;</p> <p>Internal drain: blinded plug SP-X300F ③ in Y;</p> <p>External drain: blinded plug SP-X300F ④ in Dr.</p>	
DPH*-2	Pilot channels 	Drain channels 	<p>Internal piloting: Without blinded plug SP-X300F ①;</p> <p>External piloting: Add blinded plug SP-X300F ①;</p> <p>Internal drain: Without blinded plug SP-X300F ②;</p> <p>External drain: Add blinded plug SP-X300F ②.</p>	<p>Option L9 This option provides a calibrated restrictor PLUG-H-12A (Ø 1,2 mm) in the P port of the pilot valve</p>  <p>PLUG-12A</p>
DPH*-4	Pilot channels 	Drain channels 	<p>Internal piloting: Without blinded plug SP-X500F ①;</p> <p>External piloting: Add blinded plug SP-X500F ①;</p> <p>Internal drain: Without blinded plug SP-X300F ②;</p> <p>External drain: Add blinded plug SP-X300F ②.</p>	<p>Option L9 This option provides a a calibrated restrictor PLUG-H-15A (Ø 1,5 mm) in the P port of the pilot valve</p>  <p>PLUG-15A</p>
DPH*-6	Pilot channels 	Drain channels 	<p>Internal piloting: Without plug ①;</p> <p>External piloting: Add DIN-908 M16x1,5 in pos ①; plug SP-X325A in pos ②;</p> <p>Internal drain: Without blinded plug SP-X300F ③;</p> <p>External drain: Add blinded plug SP-X300F ③.</p>	<p>To reach the orifice ②, remove plug ④ = G 1/8"</p>

DPH*-1*

ISO 4401: 2005

Mounting surface: 4401-05-05-0-05

Fastening bolts:

4 socket head screws M6x40 class 12.9

Tightening torque = 15 Nm

Diameter of ports A, B, P, T: $\varnothing = 11$ mm;

Diameter of ports X, Y: $\varnothing = 5$ mm;

Seals: 5 OR 2050, 2 OR 108

Mass (Kg)	
DPHI-16	6,8
DPHI-17	7,1
DPHE-16	6,9
DPHE-17	7,3
Option H, H9	+1,0

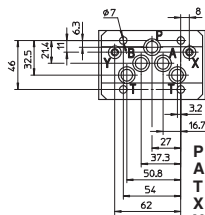

View from X

- P = PRESSURE PORT
- A, B = USE PORT
- T = TANK PORT
- X = EXTERNAL OIL PILOT PORT
- Y = DRAIN PORT

DPHI-1*/H
/H9

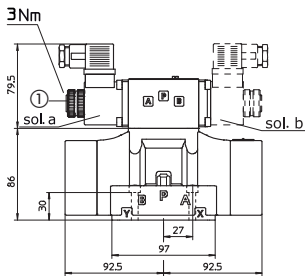
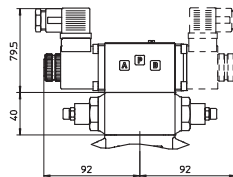

DPHI-1*

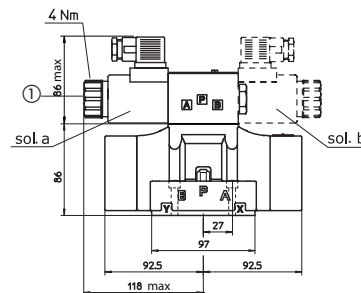

DPHE-1*

① Standard manual override PIN

DPH*-2*

ISO 4401: 2005

Mounting surface: 4401-07-07-0-05

Fastening bolts:

4 socket head screws M10x50 class 12.9

Tightening torque = 70 Nm

2 socket head screws M6x45 class 12.9

Tightening torque = 15 Nm

Diameter of ports A, B, P, T: $\varnothing = 20$ mm;

Diameter of ports X, Y: $\varnothing = 7$ mm;

Seals: 4 OR 130, 2 OR 2043

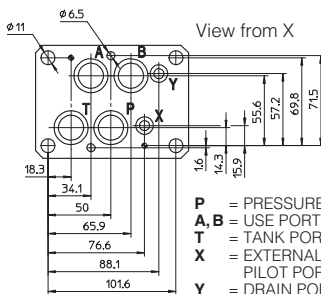

View from X

- P = PRESSURE PORT
- A, B = USE PORT
- T = TANK PORT
- X = EXTERNAL OIL PILOT PORT
- Y = DRAIN PORT

DPHI-2*/H
/H9

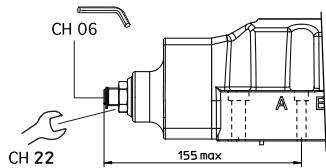
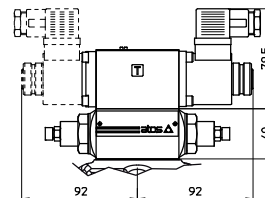

Stroke adjustment device for option /S

Mass (Kg)	
DPHI-26	9,8
DPHI-27	10,1
DPHE-26	9,9
DPHE-27	10,3
Option /S	+1,0
Option H, H9	+1,0

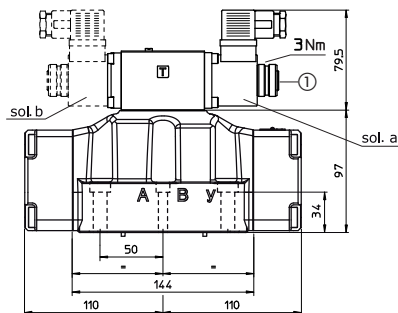

DPHI-2*

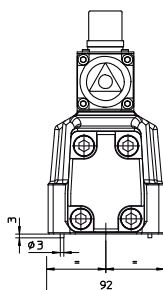

DPHE-2*

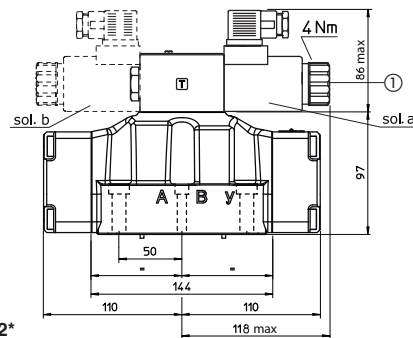

① Standard manual override PIN

Overall dimensions refer to valves with connectors type 666

DPH*-4*

ISO 4401: 2005

Mounting surface: 4401-08-08-0-05 (see table P005)

Fastening bolts:

6 socket head screws M12x60 class 12.9

Tightening torque = 125 Nm

Seals: 4 OR 4112; 2 OR 3056

Diameter of ports A, B, P, T: $\varnothing = 24$ mm;

Diameter of ports X, Y: $\varnothing = 7$ mm;

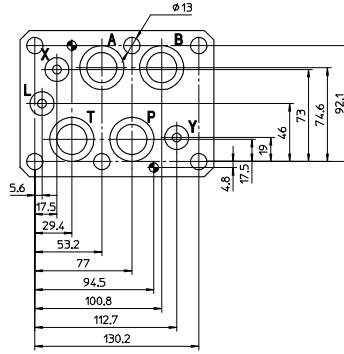

P = PRESSURE PORT
A, B = USE PORT
T = TANK PORT
X = EXTERNAL OIL PILOT PORT
Y = DRAIN PORT
 For the max pressures on ports, see section

Mass (Kg)	
DPHI-46	17,3
DPHI-47	17,6
DPHE-46	17,4
DPHE-47	17,8
Option /S	+1,5
Option H, H9	+1,0

DPHI-4*
 Stroke adjustment device for option /S

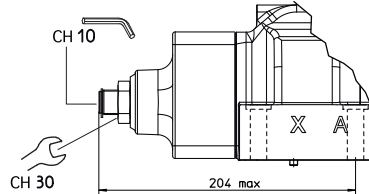

DPHI-4*/H /H9

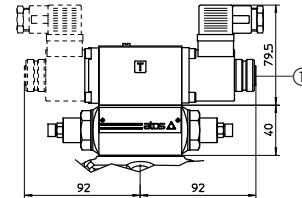

DPHI-4*

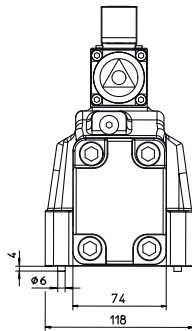
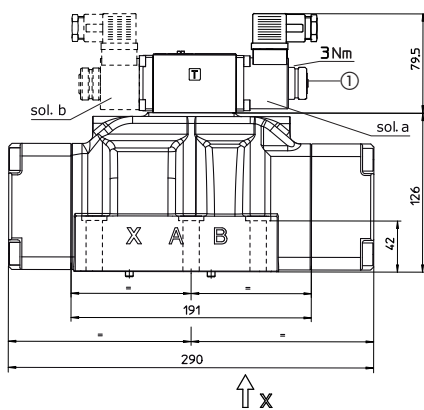

DPHE-4*

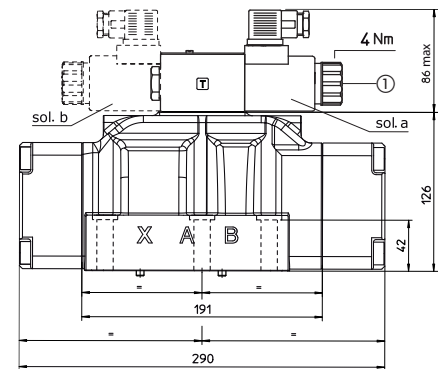

① Standard manual override PIN

Overall dimensions refer to valves with connectors type 666

13 DIMENSIONS FOR DPH*-6 [mm]

DPH*-6*

ISO 4401: 2005

Mounting surface: 4401-10-09-0-05

Fastening bolts:
6 socket head screws M20x80 class 12.9
Tightening torque = 600 Nm
Diameter of ports A, B, P, T: $\varnothing = 34$ mm;
Diameter of ports X, Y: $\varnothing = 7$ mm;
Seals: 4 OR 144, 2 OR 3056

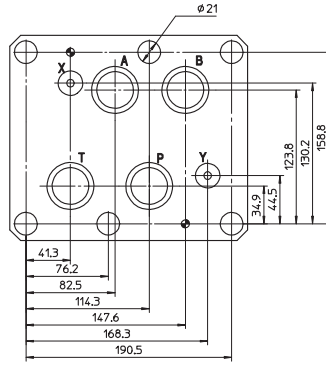

View from X

- P = PRESSURE PORT
- A, B = USE PORT
- T = TANK PORT
- X = EXTERNAL OIL PILOT PORT
- Y = DRAIN PORT

Stroke adjustment device for option/S

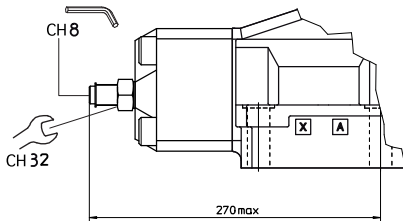

Mass (Kg)	
DPHI-66	43,8
DPHI-67	44,1
DPHE-66	44
DPHE-67	44,5
Option /S	+3,5
Option H, H9	+1,0

DPHI-6*/H /H9

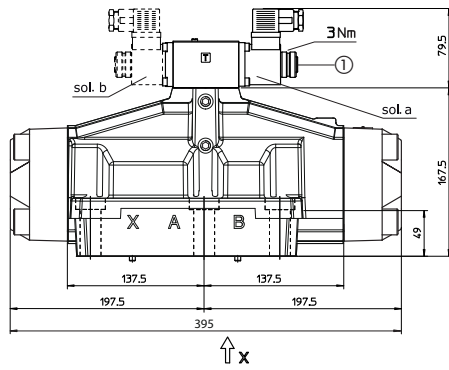
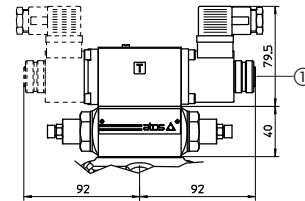

DPHI-6*

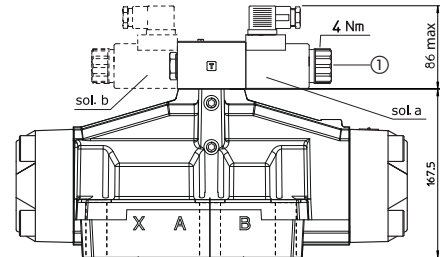
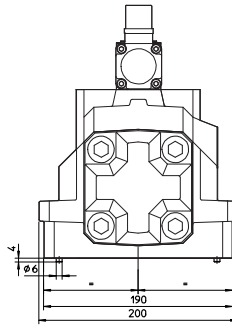

DPHE-6*

① Standard manual override PIN

Overall dimensions refer to valves with connectors type 666

14 ELECTRONIC CONNECTORS ACCORDING TO DIN 43650 - the connectors must be ordered separately

Connector code	Function
666	Connector IP65, suitable for direct connection to electric supply source
667	As 666 connector IP65 but with built-in signal led, suitable for direct connection to electric supply source
669	With built-in rectifier bridge for supplying DC coils by alternating current (AC 110V and 230V - I _{max} 1A)

For other available connectors, see tab. E010, E015 and K500

15 MOUNTING SUBPLATES FOR DPH*-1, DPH*-2, DPH*-4 AND DPH*-6

Valve	Subplate model	Ports location	Ports		Ø Counterbore [mm]		Mass [Kg]
			A, B, P, T	X, Y	A, B, P, T	X, Y	
DPH*-1	BA-428	Ports A, B, P, T, X, Y underneath;	G 3/4"	G 1/4"	36,5	21,5	5,6
DPH*-1	BA-434	Ports P, T, X, Y underneath; ports A, B on lateral side	G 3/4"	G 1/4"	36,5	21,5	5,5
DPH*-2	BA-418	Ports A, B, P, T, X, Y underneath;	G 3/4"	G 1/4"	36,5	21,5	3,5
DPH*-2	BA-518	Ports A, B, P, T, X, Y underneath;	G 1"	G 1/4"	46	21,5	8
DPH*-2	BA-519	Ports P, T, X, Y underneath; ports A, B on lateral side	G 1"	G 1/4"	46	21,5	8
DPH*-4	BA-508	Ports A, B, P, T, X, Y underneath;	G 1"	G 1/4"	46	21,5	7
DPH*-4	BA-509	Ports P, T, X, Y underneath; ports A, B on lateral	G 1"	G 1/4"	46	21,5	12,5
DPH*-6	BA-708	Ports A, B, P, T, X, Y underneath;	G 1 1/2"	G 1/4"	63,5	21,5	17

The subplates are supplied with fastening bolts. For further details see table K280