

General Description

Series R4V and R6V proportional pressure relief valves feature onboard electronics based on the functionality of the digital amplifier PCD00.

The digital onboard electronic is situated in a robust metal housing and can be used in rough environments.

The nominal values of the valves are factory set. Additionally the ProPxD software permits the editing of all parameters. The software is also used for the digital electronic modules. The cable for connection to a serial RS-232 interface is available as accessory.

The electrical connection is available in 2 options:

Code 10V: 6 + PE central connection
0...+10V command signal (preset)
+10V reference voltage output

Code 4MA: 6 + PE central connection
4...20mA command signal (preset)

The proportional solenoid operated pilot stage with integrated electronics controls a seated type main stage. The valves are available with an optional mechanical maximum pressure adjustment.

Features

- Pilot operated pressure relief valve.
- Onboard electronics.
- Factory set.
- Ramp time adjustment.
- Linearized characteristics.



R6V06

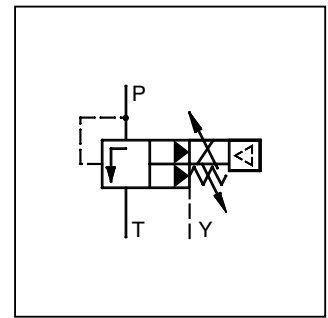

R6V

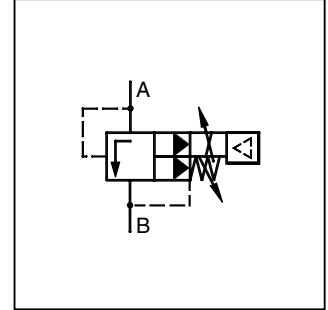

R4V

- 3 pressure ranges.
- 2 interfaces:
R4V Subplate, ISO 6264 (DIN 24340 Form D)
R6V Subplate, ISO 6264 (DIN 24340 Form E)
- Optional mechanical maximum pressure adjustment.

R4V OBE

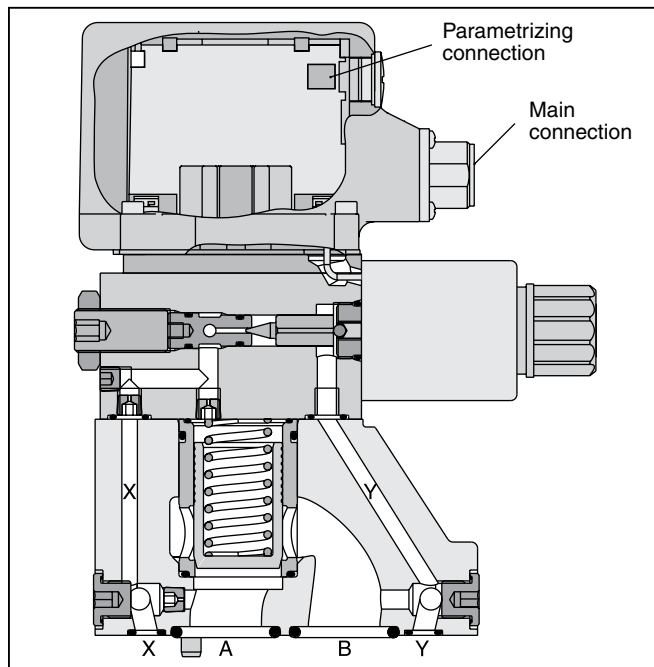

R6V OBE

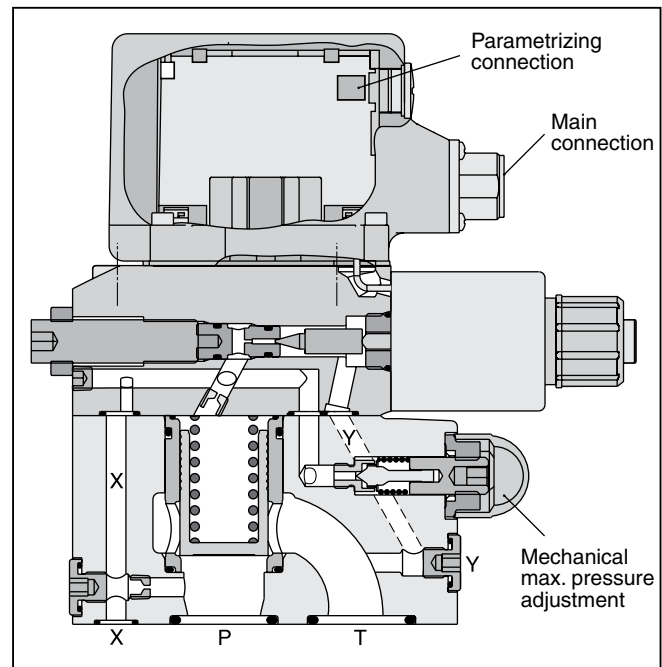

R4V-R6V-OBE.indd, ddp

Ordering Information

B

R		V		5			P						
Pressure Relief Valve	Interface	Relief Function	Size	Maximum Pressure 350 Bar (5075 PSI)	Drain Port	Pressure Range	Proportional Operation	Pilot Oil	Options	Input Signal	Design Series	Seal	Options Check with Factory

Code	Description
03	NG10
06	NG25
10	NG32

Code	Interface	Drain
3	R4V	Y-port in mounting pattern
9	R6V	Y-port = G1/8"

Code	Description
1	up to 105 Bar (1523 PSI)
3	up to 210 Bar (3045 PSI)
5	up to 350 Bar (5075 PSI)

Code	Description
10V	0...+10V with ref. output +10V
4MA	4...20mA

Code	Description
A	R4V
B	R6V

Code	Description
PN	without Mechanical maximum adjustment
PM	with Mechanical maximum adjustment

Code	Description
4	Subplate Mounting ISO 6264
6	ISO 6264

Code	Drain Port
0	Internal
1 ¹⁾	External from Subplate
2	External from Valve Body (Y-port)

¹⁾ R4V only

Bolt Kits:

R4V03	BK505
R4V06	BK485
R4V10	BK506
R6V03	BK494
R6V06	BK366
R6V10	BK507

Weight:

R4V03	4.5 kg (9.9 lbs.)
R4V06	6.3 kg (13.9 lbs.)
R4V10	7.8 kg (17.2 lbs.)
R6V03	5.4 kg (11.9 lbs.)
R6V06	6.6 kg (14.6 lbs.)
R6V10	8.6 kg (19.0 lbs.)

Performance Curves

Signal/Pressure Curve – R4V

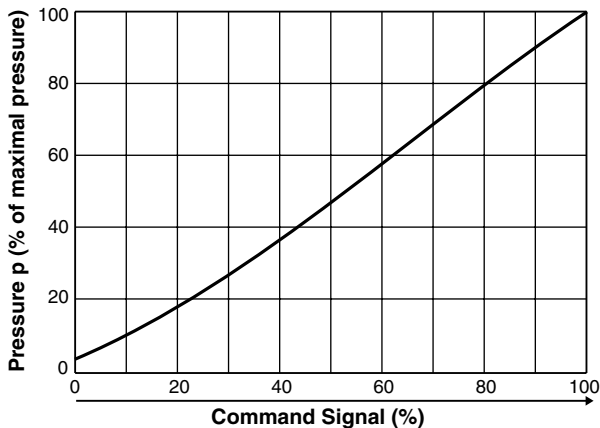

Signal/Pressure Curve – R6V

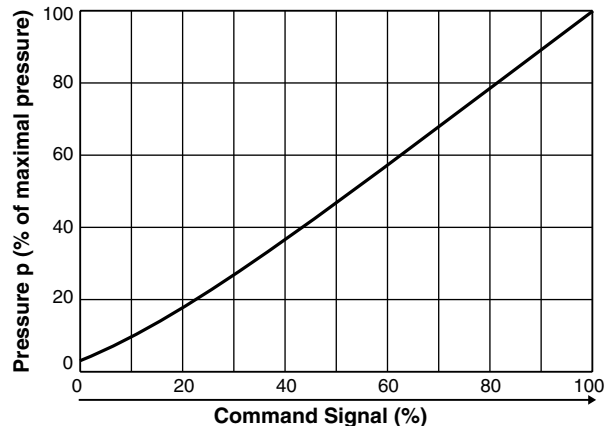

R4V-R6V-OBE.indd, ddp



General				
Size		NG10	NG25	NG32
Interface		Subplate mounting acc. ISO 6264		
Mounting Position		as desired, horizontal mounting preferred		
Ambient Temperature	[°C]	-20...+60; (-4°F ... +140°F)		
MTTF _D Value	[years]	50		
Vibration Strength	[g]	10 sinus 5...2000 Hz acc. to IEC 68-2-6 30 noise 20...2000 Hz acc. to IEC 68-2-36 15 shock acc. to IEC 68-2-27		
Hydraulic				
Maximum Operating Pressure		Ports P (or A) and X up to 350 Bar (5075 PSI), port T (or B) and Y 30 Bar (435 PSI)		
Pressure Range		105 Bar (1523 PSI), 210 Bar (3045 PSI), 350 (5075 PSI)		
Nominal Flow				
Series R4V		150 LPM (39.7 GPM)	350 LPM (92.6 GPM)	650 LPM (172.0 GPM)
Series R6V		250 LPM (66.1 GPM)	500 LPM (132.3 GPM)	650 LPM (172.0 GPM)
Fluid		Hydraulic oil according to DIN 51524...51535, other on request		
Viscosity				
Recommended	[cSt] / [mm ² /s]	30 ... 50 (139 ... 232 SSU)		
Permitted	[cSt] / [mm ² /s]	20 ... 380 (93 ... 1761 SSU)		
Fluid Temperature	[°C]	-20 ... +60; (-4°F ... +140°F)		
Filtration		ISO 4406 (1999); 18/16/13 (acc. NAS 1638: 7)		
Hysteresis	[%]	< 1.5		
Electrical				
Duty Ratio	[%]	100 ED; CAUTION: Coil temperature up to 150°C (302°F) possible		
Supply Voltage	VDC	18...30, ripple < 5% eff., surge free		
Current Consumption Maximum	[A]	2.0		
Pre-fusing	[A]	2.5 medium lag		
Potentiometer Supply	[V]	+10 / ±5% max. 10mA		
Command Signal				
Code 10V Voltage	[V]	0...+10, ripple < 0.01 % eff., surge free, Ri = 100 kOhm		
Code 4MA Current	[mA]	4...20, ripple < 0.01 % eff., surge free, Ri = 200 Ohm < 3.6 mA = enable off, > 3.8 mA = enable on (acc. NAMUR NE43)		
Differential Input Voltage Max.	[V]	30 for terminal D and E against PE (terminal G)		
	[V]	11 for terminal D and E against 0V (terminal B)		
Adjustment Ranges				
Minimum current	[%]	0...50		
Maximum current	[%]	50...100		
Ramp	[s]	0...32.5		
Interface		RS-232, parametrizing connection 5 pole		
EMC		EN 61000-6-2, EN 61000-6-4		
Central Connection		6 + PE acc. EN 175201-804		
Cable Specification	[mm ²]	7 x 1.0 (AWG 18) overall braid shield		
Cable Length Maximum	[m]	50 (164 ft.)		

B

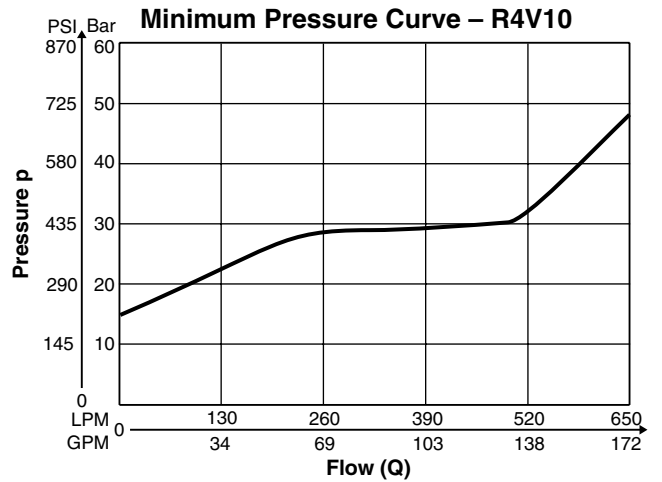
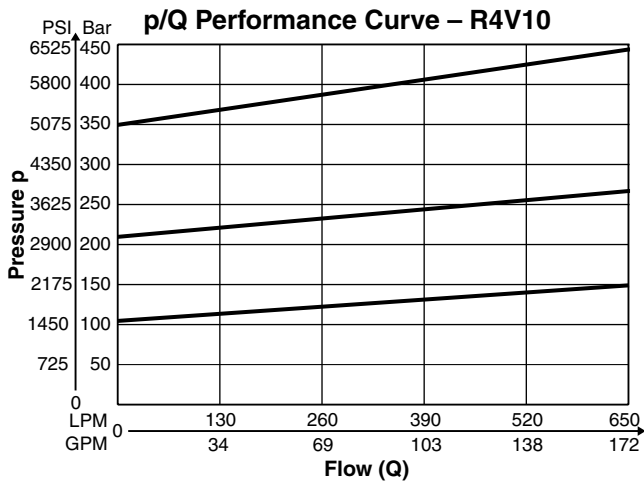
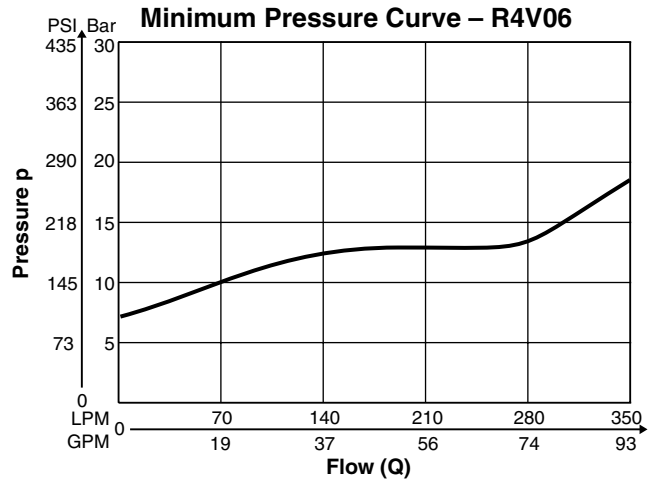
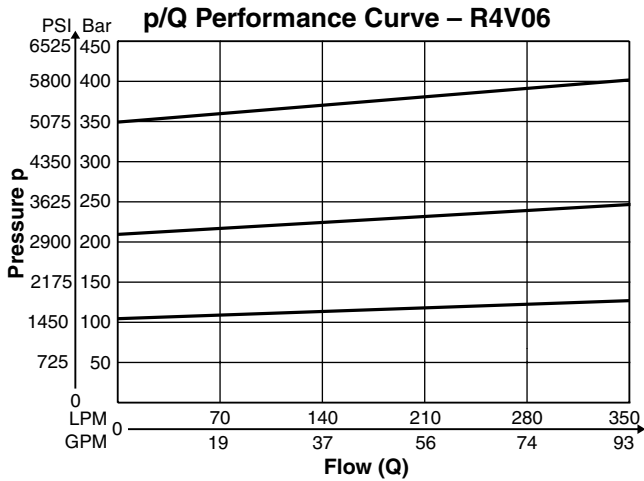
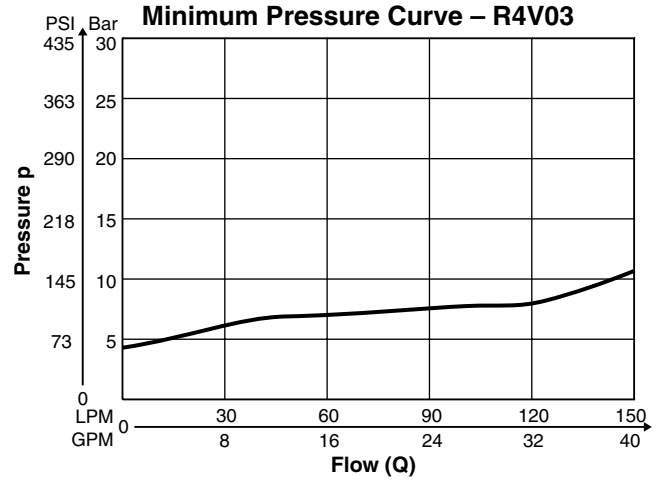
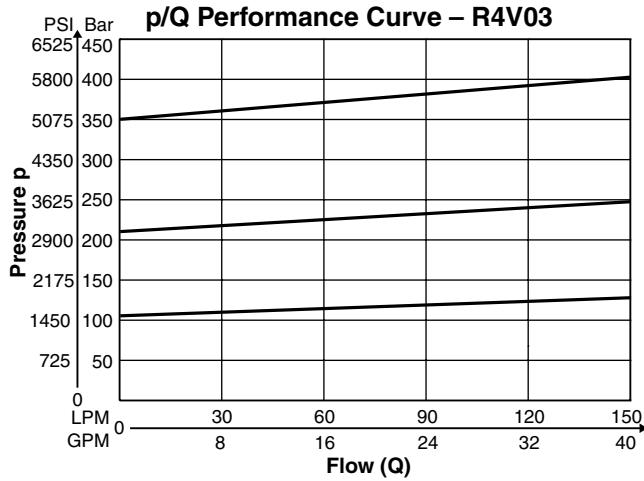

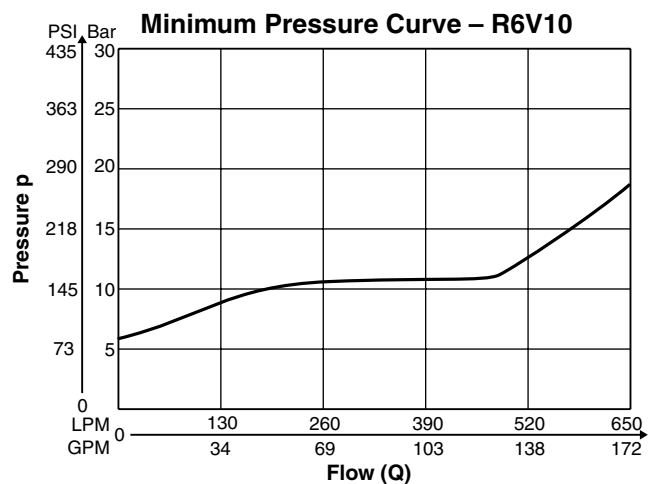
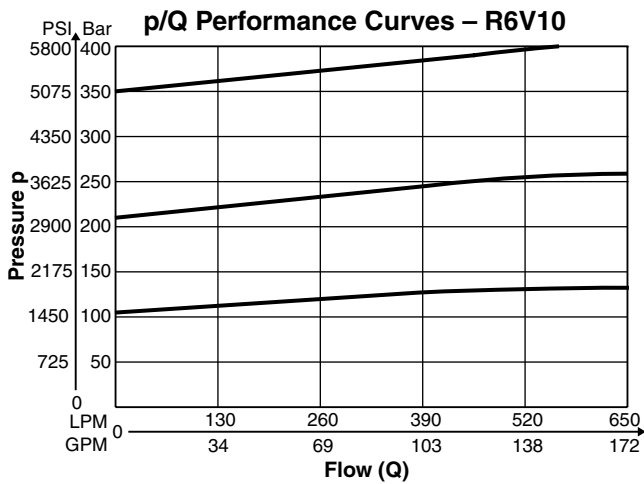
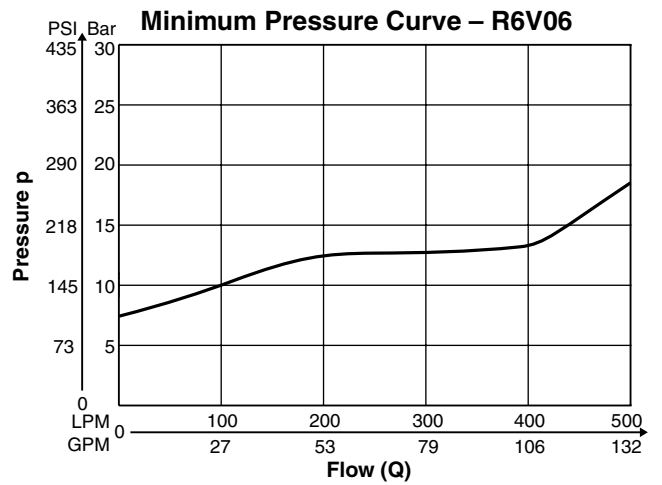
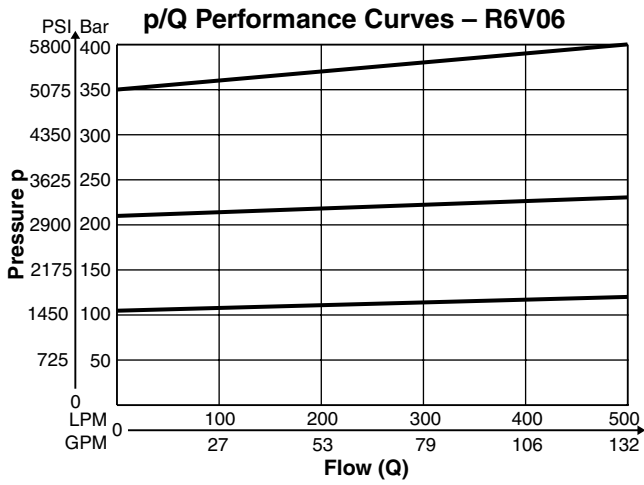
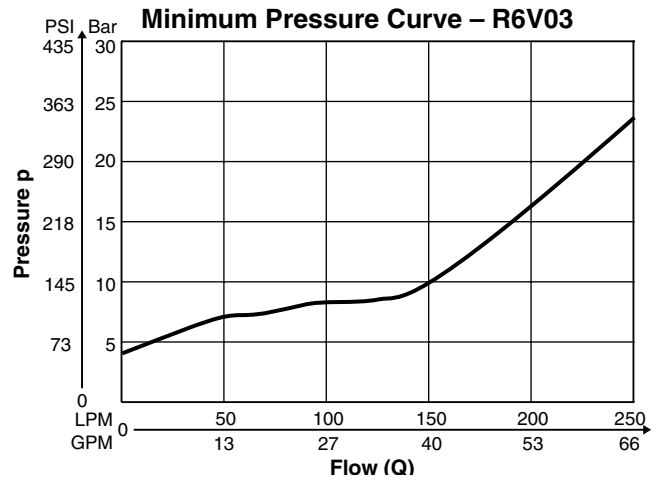
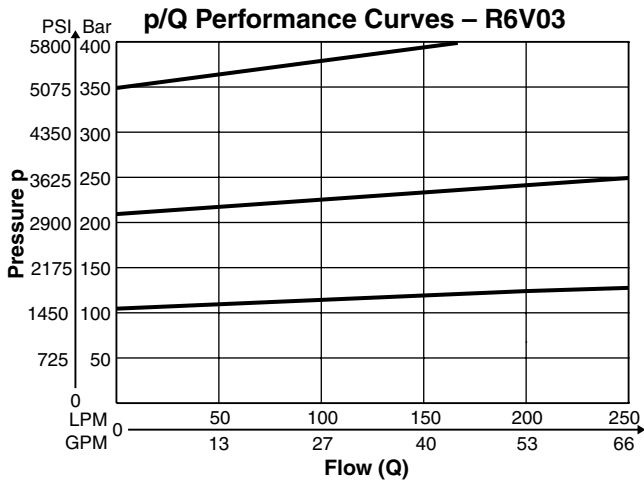

Code 10V
 6 + PE acc. EN 175201-804

B

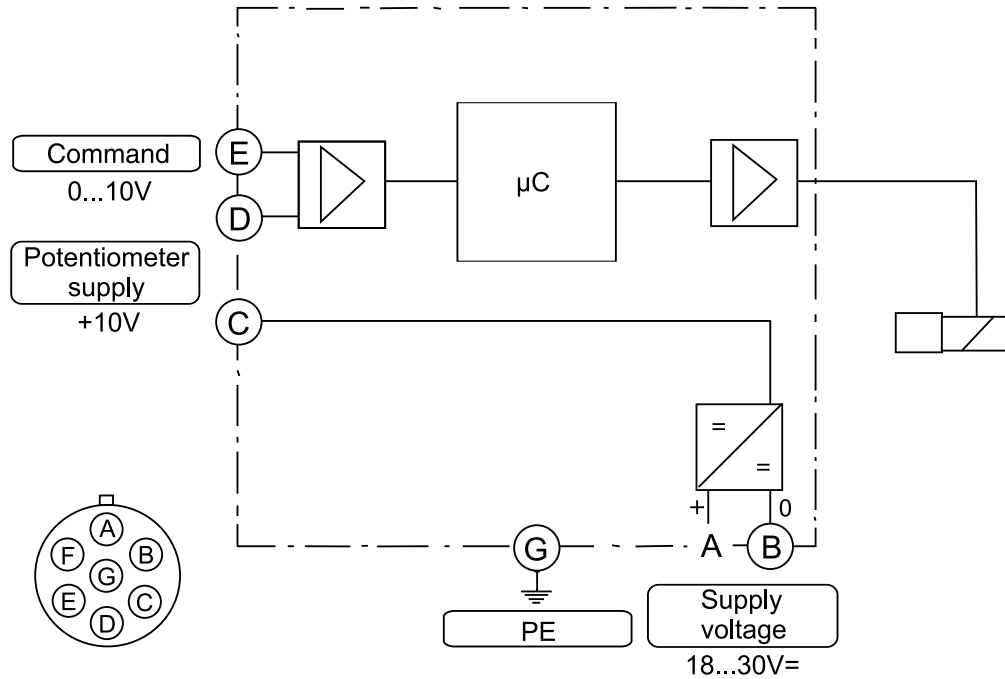

Code 4MA
 6 + PE acc. EN 175201-804

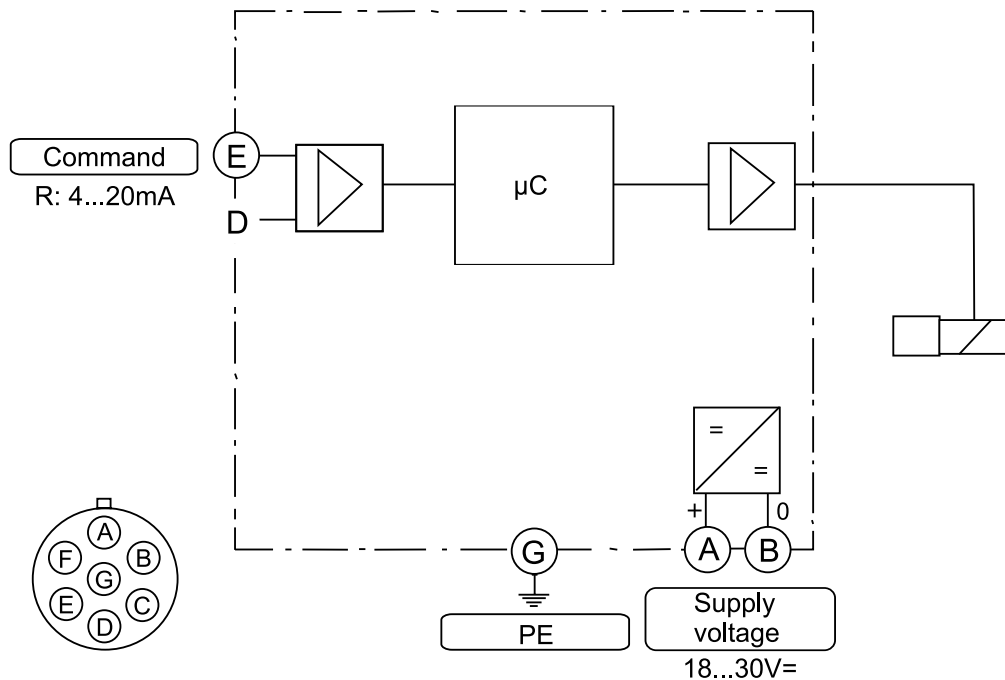

ProPxD Interface Program

The ProPxD software allows quick and easy setting of the digital valve electronics. Individual parameters as well as complete settings can be viewed, changed and saved via the comfortable user interface. Parameter sets saved in the non-volatile memory can be loaded to other valves of the same type or printed out for documentation purposes.

Features

- Simple editing of all parameters.
- Storage and loading of optimized parameter adjustments.
- Executable with all Windows® operating systems from Windows® 95 upwards.
- Communication between PC and electronics via serial interface RS-232.

The valve electronics cannot be connected to a PC with a standard USB cable – this can result in damages of PC and/or valve electronics.

Simple to use interface program. Download free of charge www.parker.com/euro_hcd → **Services** → **downloads**

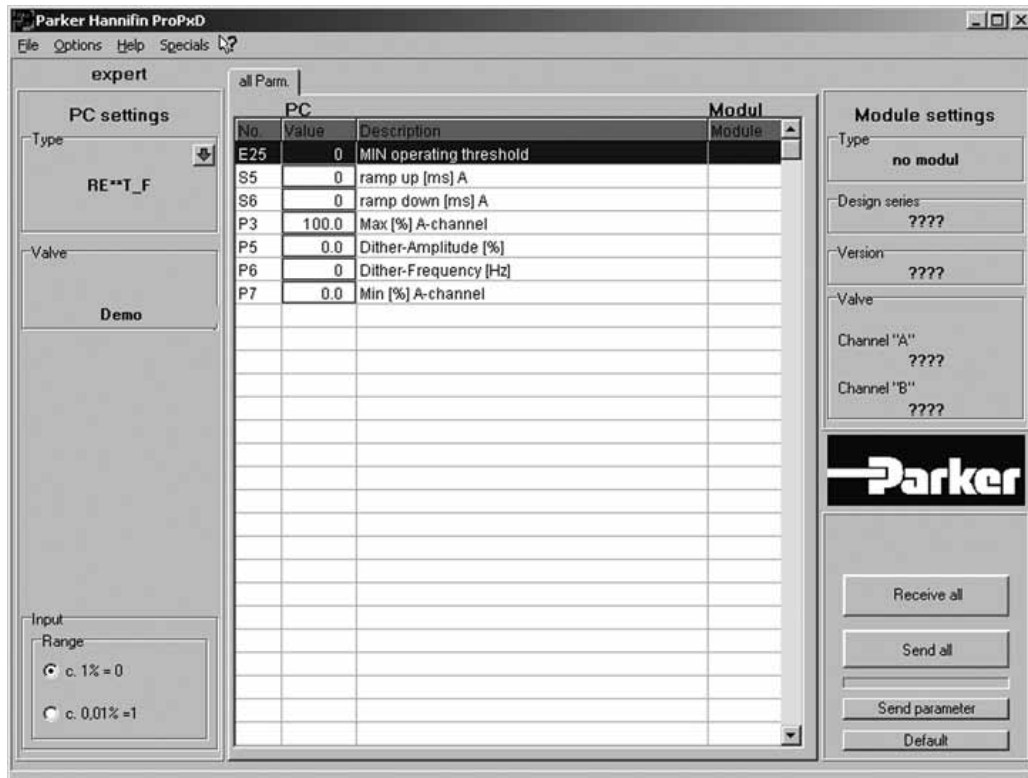

The parametrizing cable may be ordered under item no. 40982923.

B

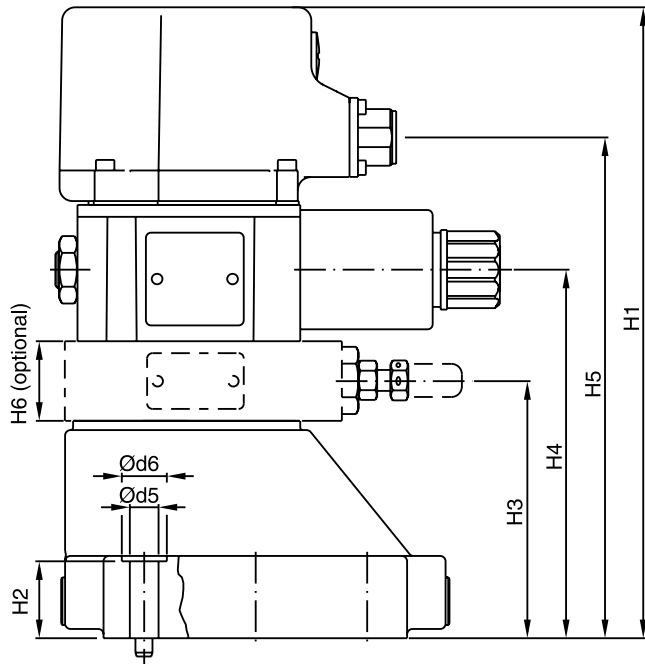
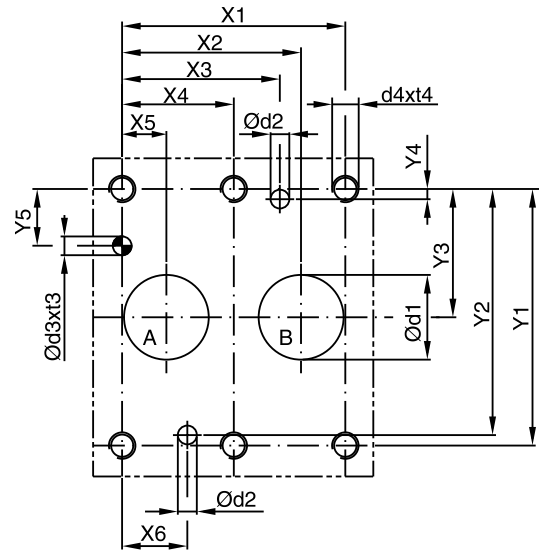
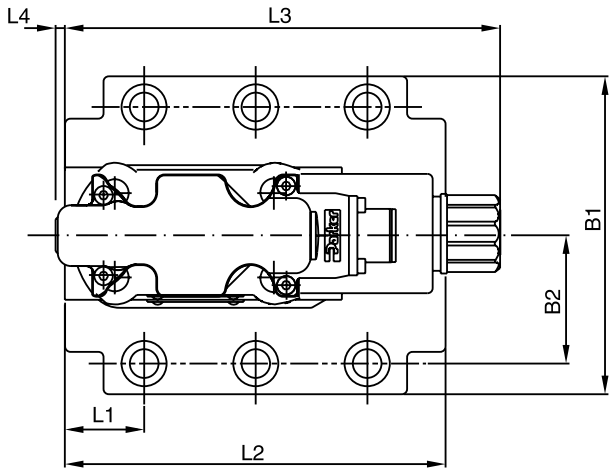

Dimensions

**Proportional Pressure Relief Valves
Series R4V (Onboard Electronics)**

Return to
ALPHA
TOC

Return to
SECTION
TOC



Inch equivalents for millimeter dimensions are shown in (**)

NG	ISO-Code	x1	x2	x3	x4	x5	x6	x7	y1	y2	y3	y4	y5	y6
10	6264-06-07-*-97	42.9 (1.69)	35.8 (1.41)	21.5 (0.85)	-	7.2 (0.28)	21.5 (0.85)	0	66.7 (2.63)	58.8 (2.31)	33.4 (1.31)	7.9 (0.31)	14.3 (0.56)	-
25	6264-08-11-*-97	60.3 (2.37)	49.2 (1.94)	39.7 (1.56)	-	11.1 (0.44)	20.6 (0.81)	0	79.4 (3.13)	73 (2.87)	39.7 (1.56)	6.4 (0.25)	15.9 (0.63)	-
32	6264-10-15-*-97	84.2 (3.31)	67.5 (2.66)	59.5 (2.34)	42.1 (1.66)	16.7 (0.66)	24.6 (0.97)	0	96.8 (3.81)	92.8 (3.65)	48.4 (1.91)	3.8 (0.15)	21.4 (0.84)	-

Tolerance at X and Y pin holes and screw holes ±0.1, at port holes ±0.2.

NG	ISO-Code	B1	B2	H1	H2	H3	H4	H5	H6	L1	L2	L3	L4	L5	L6
10	6264-06-07-*-97	87.3 (3.44)	33.4 (1.31)	200.3 (7.89)	21.0 (0.83)	60.0 (2.36)	102.0 (4.02)	151.0 (5.94)	30.0 (1.18)	25.0 (0.98)	90.8 (3.57)	164.2 (6.46)	4.5 (0.18)	-	-
25	6264-08-11-*-97	105.0 (4.13)	39.7 (1.56)	226.8 (8.93)	29.0 (1.14)	86.5 (3.41)	128.5 (5.06)	184.0 (7.24)	30.0 (1.18)	30.9 (1.22)	123.0 (4.84)	164.2 (6.46)	4.5 (0.18)	-	-
32	6264-10-15-*-97	120.0 (4.72)	48.4 (1.91)	237.3 (9.34)	29.0 (1.14)	97.0 (3.82)	139.0 (5.47)	194.5 (7.66)	30.0 (1.18)	29.8 (1.17)	143.5 (5.65)	164.2 (6.46)	4.5 (0.18)	-	-

NG	ISO-Code	d1max	d2max	d3	t3	d4	t4	d5	d6	Subplate
10	6264-06-07-*-97	15.0 (0.59)	7.0 (0.28)	7.1 (0.28)	8.0 (0.31)	M10	16.0 (0.63)	10.8 (0.43)	17.0 (0.67)	SPP3M6B910
25	6264-08-11-*-97	23.4 (0.92)	7.1 (0.28)	7.1 (0.28)	8.0 (0.31)	M10	18.0 (0.71)	10.8 (0.43)	17.0 (0.67)	SPP6M8B910
32	6264-10-15-*-97	32.0 (1.26)	7.1 (0.28)	7.1 (0.28)	8.0 (0.31)	M10	20.0 (0.79)	10.8 (0.43)	17.0 (0.67)	SPP10M12B910

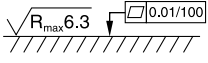
NG	ISO-Code	Bolt Kit			Seal  Kit		Surface Finish
					Nitrile	Fluorocarbon	
10	6264-06-07-*-97	BK505	4x M10 x 35 DIN912 12.9	63 Nm (46.5 lb.-ft.) ±15%	S26-58507-0*	S26-58507-5*	
25	6264-08-11-*-97	BK485	4x M10 x 45 DIN912 12.9	63 Nm (46.5 lb.-ft.) ±15%	S26-58475-0*	S26-58475-5*	
32	6264-10-15-*-97	BK506	6x M10 x 45 DIN912 12.9	63 Nm (46.5 lb.-ft.) ±15%	S26-58508-0*	S26-58508-5*	
Prop. Section P2*					S26-58473-0	S26-58473-5	

* Please combine seal kit of one size with seal kit of Prop. Section P2 for complete seal kit.

B

B

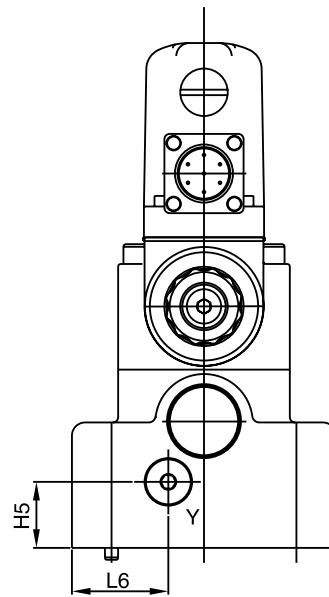
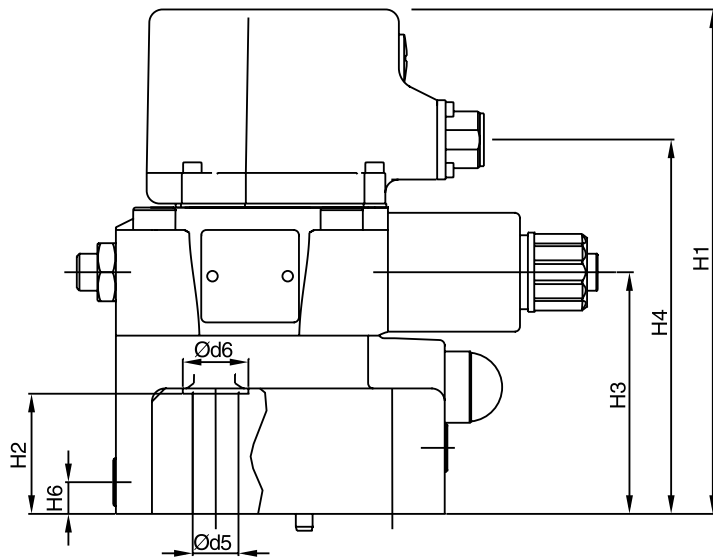
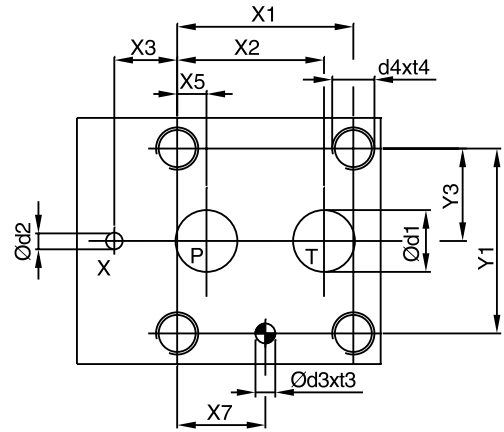
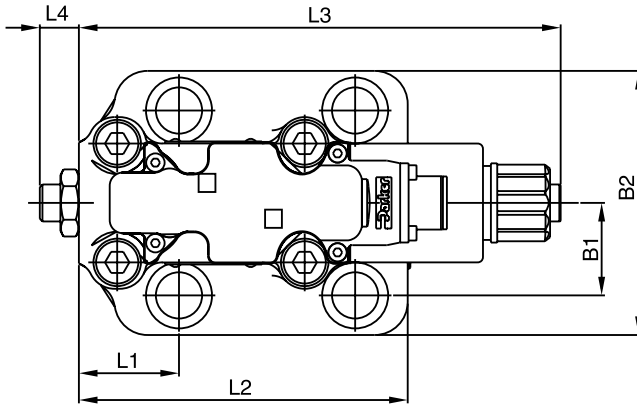

Y: external drain
port G 1/8"

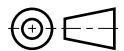

Dimensions

**Proportional Pressure Relief Valves
Series R6V (Onboard Electronics)**

Return to
ALPHA
TOC

Return to
SECTION
TOC



Inch equivalents for millimeter dimensions are shown in (**)

NG	ISO-Code	x1	x2	x3	x4	x5	x6	x7	y1	y2	y3	y4	y5	y6
10	6264-06-09-*-97	53.8 (2.12)	47.5 (1.87)	0.0 (0.00)	-	22.1 (0.87)	-	22.1 (0.87)	53.8 (2.12)	-	26.9 (1.06)	-	-	-
25	6264-08-13-*-97	66.7 (2.63)	55.6 (2.19)	23.8 (0.94)	-	11.1 (0.44)	-	33.4 (1.31)	70.0 (2.76)	-	35.0 (1.38)	-	-	-
32	6264-10-17-*-97	88.9 (3.50)	76.2 (3.00)	31.8 (1.25)	-	12.7 (0.50)	-	44.5 (1.75)	82.6 (3.25)	-	41.3 (1.63)	-	-	-

Tolerance at X and Y pin holes and screw holes ±0.1, at port holes ±0.2.

NG	ISO-Code	B1	B2	H1	H2	H3	H4	H5	H6	L1	L2	L3	L4	L5	L6
10	6264-06-09-*-97	80.0 (3.15)	26.9 (1.06)	185.1 (7.29)	27.0 (1.06)	88.0 (3.46)	135.8 (5.35)	20.5 (0.81)	25.0 (0.98)	52.0 (2.05)	117.0 (4.61)	182.3 (7.18)	14.4 (0.57)	-	29.5 (1.16)
25	6264-08-13-*-97	100.0 (3.94)	35.0 (1.38)	188.6 (7.43)	45.5 (1.79)	91.5 (3.60)	139.8 (5.50)	25.0 (0.98)	12.0 (0.47)	37.9 (1.49)	124.5 (4.90)	182.3 (7.18)	14.4 (0.57)	-	36.5 (1.44)
32	6264-10-17-*-97	120.0 (4.72)	41.3 (1.63)	194.1 (7.64)	52.0 (2.05)	97.0 (3.82)	144.8 (5.70)	26.5 (1.04)	13.5 (0.53)	44.3 (1.74)	153.0 (6.02)	182.3 (7.18)	14.4 (0.57)	-	46.5 (1.83)

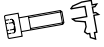
NG	ISO-Code	d1max	d2max	d3	t3	d4	t4	d5	d6	Subplate
10	6264-06-09-*-97	14.7 (0.58)	4.8 (0.19)	7.5 (0.30)	10.0 (0.39)	M12	20.0 (0.79)	13.5 (0.53)	20.0 (0.79)	SPP3R6B910
25	6264-08-13-*-97	23.4 (0.92)	6.3 (0.25)	7.5 (0.30)	10.0 (0.39)	M16	27.0 (1.06)	17.5 (0.69)	25.0 (0.98)	SPP6R10B910
32	6264-10-17-*-97	32.0 (1.26)	6.3 (0.25)	7.5 (0.30)	10.0 (0.39)	M18	28.0 (1.10)	20.0 (0.79)	30.0 (1.18)	SPP10R12B910

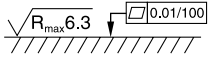
NG	ISO-Code	Bolt Kit			Seal Kit		Surface Finish
					Nitrile	Fluorocarbon	
10	6264-06-09-*-97	BK494	4x M12 x 45 DIN912 12.9	108 Nm (79.7 lb.-ft.) ±15%	S26-98589-0	S26-98589-5	
25	6264-08-13-*-97	BK366	4x M16 x 70 DIN912 12.9	264 Nm (194.7 lb.-ft.) ±15%	S26-96396-0	S26-96396-5	
32	6264-10-17-*-97	BK507	4x M18 x 75 DIN912 12.9	398 Nm (293.5 lb.-ft.) ±15%	S26-96392-0	S26-96392-5	

B