

Section C
www.parker.com/pneu/int2000

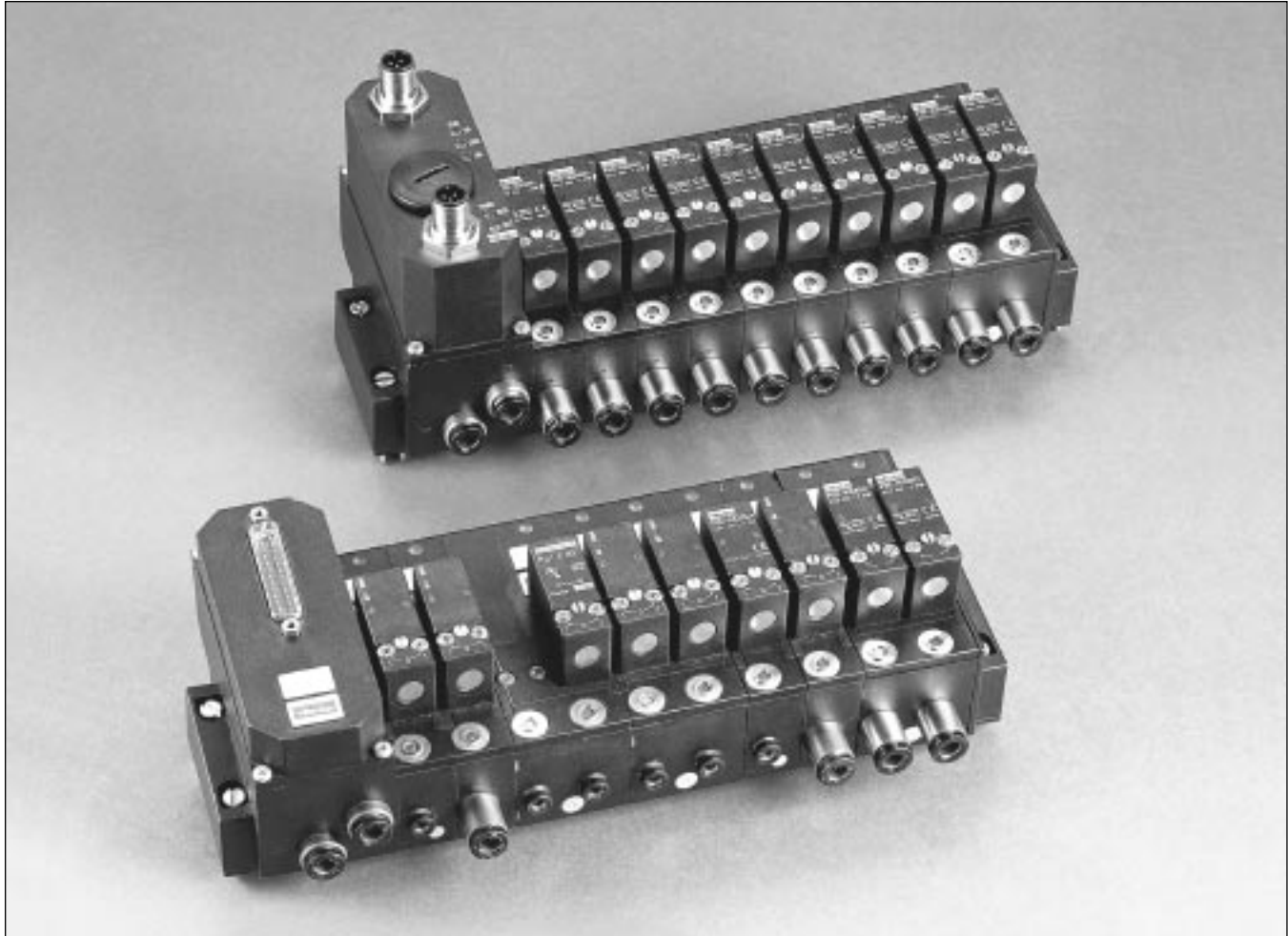

Features	C2	Parts & Accessories	
Model Selection		IP65 Cable Assemblies	C9
Valves with Solenoid Operators	C3-C4	35mm DIN Rail	C9
Head & Tail Sets and		Dimensions	C10
Intermediate Air Supply Modules	C5		
Head & Tail Sets with			
How To Order	C6		
Replacement Solenoid Kits	C7		
Technical Information			
Valve Specifications	C8		
Pin Out Information	C9		

BOLD ITEMS ARE MOST POPULAR.

Compact, easy to install, reliable, serial bus compatible...

Easy to Meet System Design Needs

- Full Flow Capacity Allows Direct Operation of Small Cylinders (Single or Double Acting) or Pneumatic Piloting of Larger Control Valves (Pneumatic or Hydraulic)
- Valve Configurations in 3/2 or 4/2 (Single or Double Acting)
- 5/32" or 1/4" Push-in Tube Fittings
- System Modification or Expansion Simplified by Easily Adding Modules to Stack
- Wide Range of Voltages Available.
- Solenoids are CE Marked
- Multiple Pressures Possible in One Assembly
- Compatibility With *DeviceNet™*
- Surge Suppression, LED's and Overvoltage Protection Standard

Easy to Install in Your System

- Modules Snap Together and Mount on 35mm (Din) Rail
- Common Air Supply and Exhaust Connections Through the Manifold
- Completely Modular Design with High Protection (IP65)
- Small Serial Bus Electronic Package
- Automatic Addressing of Up to 16 Valves

Easy to Maintain System Operation

- Manual Override for Setup and Troubleshooting
- Poppet Design for Long, Trouble Free Life (Lubricated or Non-lubricated Air)
- Integrated Diagnostics (Main Air Test Point, Pneumatic Output Indicator, Suppressor / LED) Provide System Status at a Glance.
- Modular Design and Easy Connection Aid in Module Replacement or System Expansion.

Interface 2000 Manifold Assembly

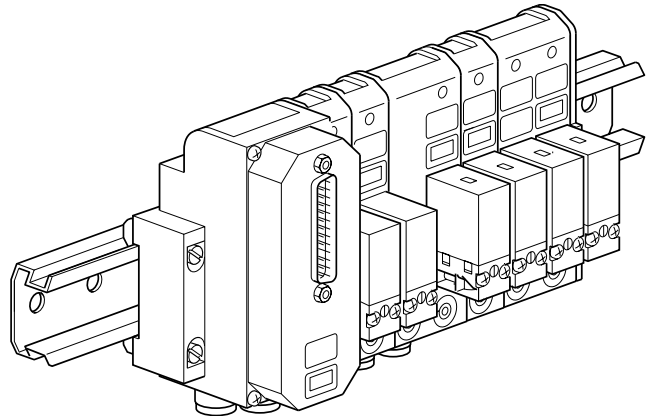

3/2 NO, 3/2 NC and 4/2 Function

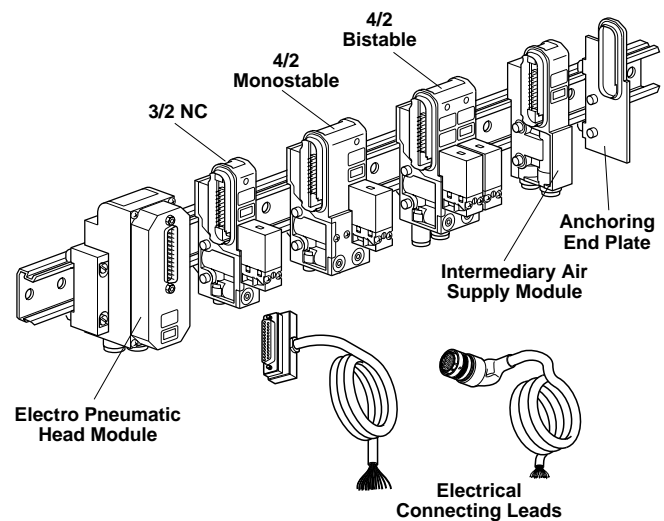

Valves Only
(Solenoids Sold Separately)

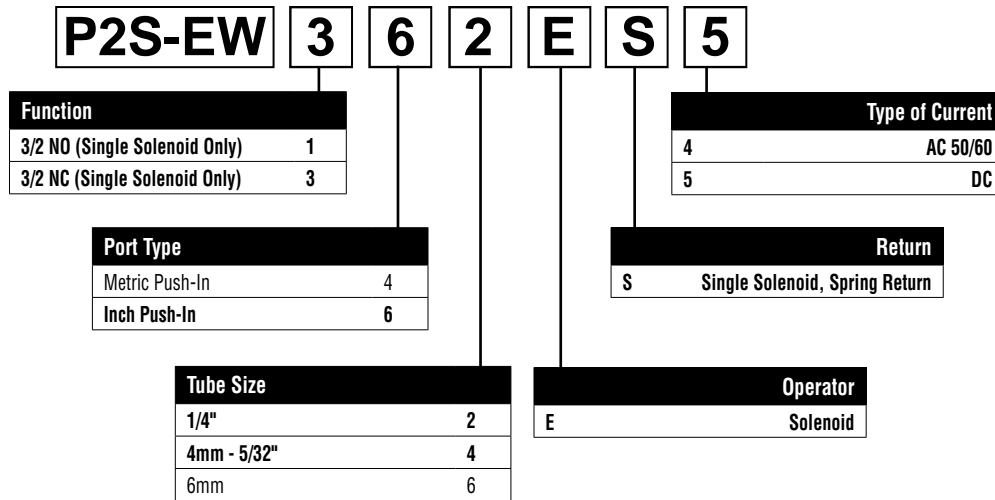

C

BOLD OPTIONS ARE MOST POPULAR.

Notes:

- All units include pop-up indicator for pneumatic output.
 Red indicates NNP / NC function,
 Yellow indicates NP / NO function.
- Solenoids must be ordered separately. See page C7.**
- All units include screws and gaskets for mounting solenoids.

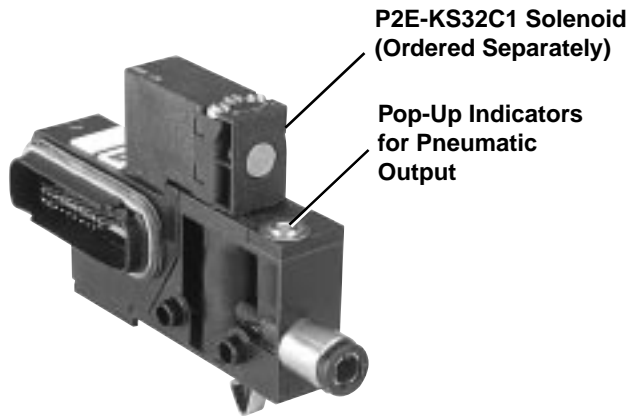

P2S-EW362ES5
 Single Solenoid - Spring Return 3/2
 (Shown with 1/4" Push-In Fitting)

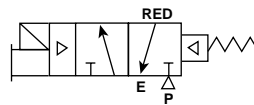

Valves Only
 (Solenoids Sold Separately)

C

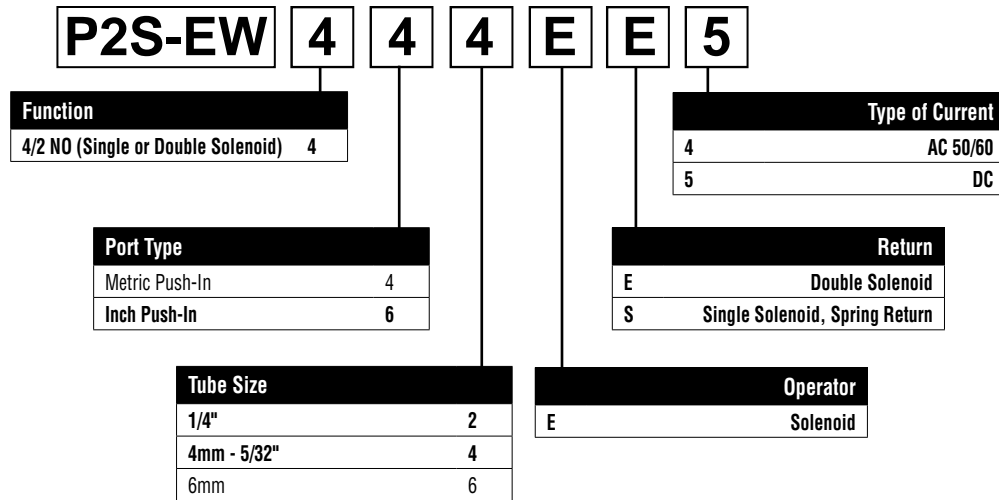

BOLD OPTIONS ARE MOST POPULAR.

Notes:

- All units include pop-up indicator for pneumatic output.
 Red indicates NNP / NC function,
 Yellow indicates NP / NO function.
- Solenoids must be ordered separately. See page E8

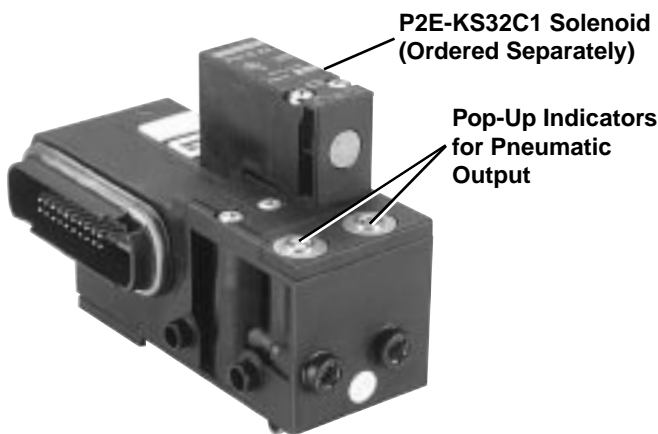

P2S-EW444ES5
 (Shown with 5/32" - 4mm Push-In Fitting)

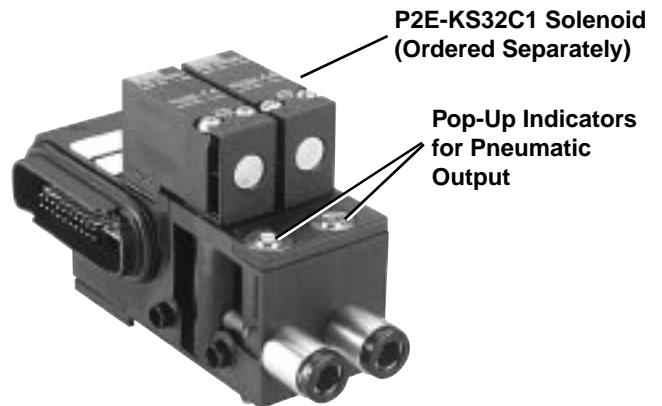
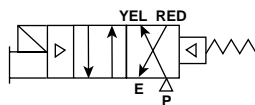

P2S-EW446EE5
 (Shown with 6mm Push-In Fitting)

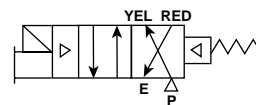

Head & Tail Sets and Intermediate Air Supply Modules

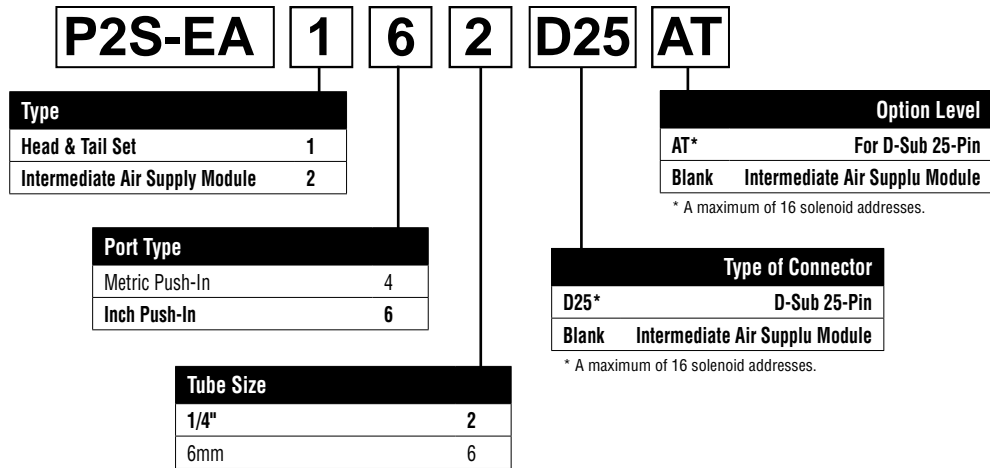

C

BOLD OPTIONS ARE MOST POPULAR.



P2S-EA162D25AT
 Head & Tail Set with
 D-Sub 25-Pin Connector



P2S-EA262
 Intermediate Air Supply Module

Head and Tail Sets

Used to mount valves to DIN Rail and provide supply and exhaust ports. All hardware is included.

1/4" Push-in Connection Ports	
P2S-EA162D25AT	With D-Sub, 25-Pin Connector

Intermediate Air Supply Module

Used when multiple pressures are required on a manifold. Plugs are included to isolate supply and / or exhaust ports.

P2S-EA262	1/4" Push-In Connection Ports
P2S-EA246	6mm Push-In Connection Ports

How to Order

Example 1:

When application requires ten, 3/2 NC, Interface 2000 valves with 1/4" tube size, 24VDC with D-Sub, 25-Pin Connector, please order accordingly.

Qty.	Part Number	Description
10	P2S-EW362ES5 with P2E-KS32C1	3/2 NC, 24VDC, 1/4" Tube Valves
1	P2S-EA162D25AT	Head & Tail Set with D-Sub, 25-Pin Connector, 1/4" Tube

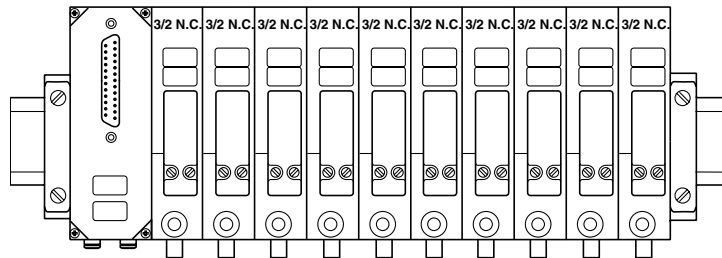

Example 1

Example 2:

When application requires five, 3/2 NC and five 4/2 single solenoid Interface 2000 valves with Intermediate Air Supply Module with 1/4" tube size, 24VDC with D-Sub, please order accordingly.

Qty.	Part Number	Description
5	P2S-EW362ES5 with P2E-KS32C1	3/2 NC, 24VDC, 1/4" Tube Valves
1	P2S-EA262	Intermediate Air Supply Module, 1/4" Tube
5	P2S-EW444EE2 with P2E-KS32C1	4/2 Single Solenoid, 24VDC, 1/4" Tube Valves
1	P2S-EA162D25AT	Head & Tail Set with D-Sub, 25-Pin Connector, 1/4" Tube

Isolator plugs provided with the Intermediate Air Supply Module have to be mounted on the left hand side of the Intermediate Air Supply Module. This isolates the 3/2 NC valves on the left hand side.

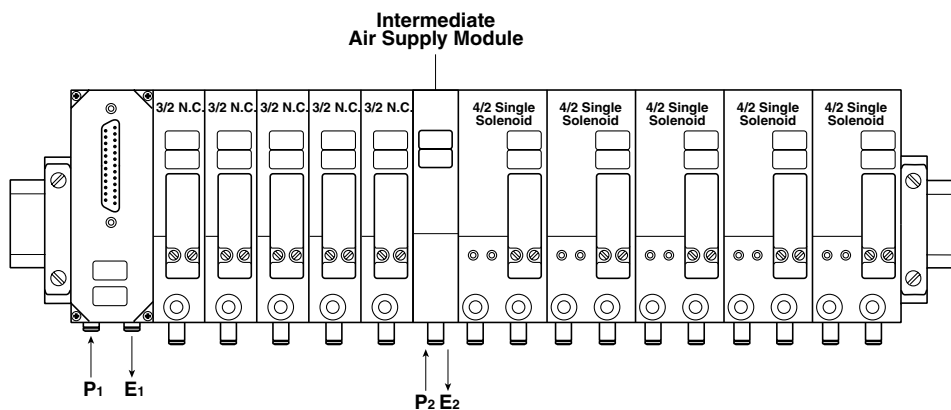

Example 2

NC (NNP) Solenoids / Kits

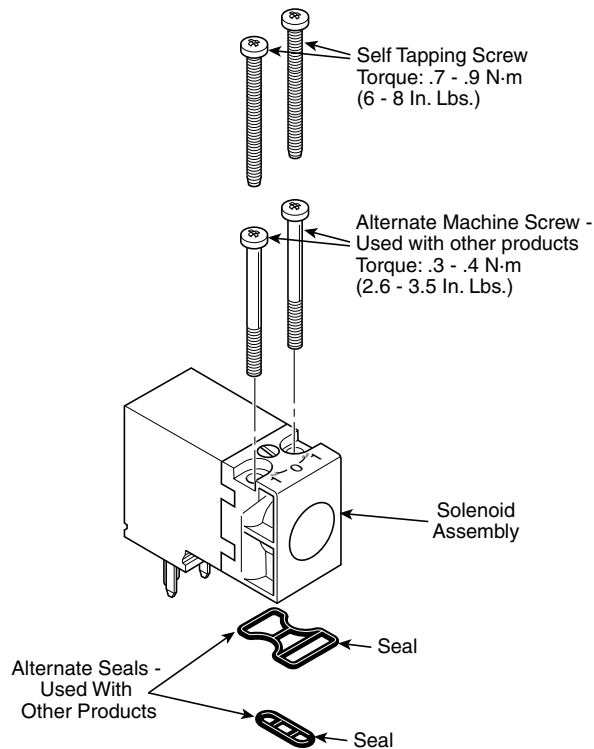

Voltages	Power Consumption	Holding Current	Id (Drop-Out Current)*	Kit Numbers With Non-Locking Flush Manual Override	Solenoid Only	Kit Numbers With Locking Flush Manual Override	Solenoid Only
12VDC	1.2W	100 mA	10 mA	PS3441B45P	P2E-KS32B1	PS3441C45P	P2E-KS32B2
24VDC	1.2W	50 mA	5 mA	PS3441B49P	P2E-KS32C1	PS3441C49P	P2E-KS32C2
24VAC	1.6VA	65 mA	22 mA	PS3441B42P	P2E-KS31C1	PS3441C42P	P2E-KS31C2
110VAC, 50Hz 120VAC, 60Hz	1.6VA	13.3 mA	5 mA	PS3441B53P	P2E-KS31F1	PS3441C53P	P2E-KS31F2

* When using a programmable controller, be sure that the leakage current of the controller outputs is lower than the drop-out current value.

Notes:

Kit includes: Solenoid, (2) machine screws, (2) self threading screws, (1) gasket, (1) 3-cell gasket.

BOLD ITEMS ARE MOST POPULAR.

Technical Data

Electrical Interface Per:

Din 43650 Form C

Pneumatic Interface Per:

Afnor E 0652 110 N

Protection:

IP65 (Washdown)

Air Flow:

Standard Flow 0.033 Cv (33 Lpm) (1.2W) (1.6VA)

High Flow 0.05 Cv (50 Lpm) (1.8W) (2.4VA)

Operating Temperature:

Standard Flow: 5°F to 140°F (-15°C to 60°C)

High Flow: 5°F to 122°F (-15°C to 50°C)

Mobile Applications (47 & 48 Voltage Options):

-40°F to 158°F (-40°C to 70°C)

Operating Pressure:

Vacuum to 145 PSIG (Vacuum to 10 bar)

Storage Temperature:

All Applications: -40°F to 158°F (-40°C to 70°C)

Voltage Tolerance:

All Voltages Except 47 & 48: Rated Voltage +10% / -15%

Options 47 & 48: Rated Voltage +25% / -30%

Materials

Valve:

Body: Glass Filled Polyamide

Internal Metal Parts: Steel

Screws: Steel

Bottom Plug: Thermoplastic

Poppet Seals: Nitrile for Standard, Fluorocarbon for Mobile



Valve Specifications

Air Flow:

0.19 Cv, 200NL/min

Air Quality:

Standard shop air, lubricated or non-lubricated, 50µ filtered

Body Material:

Glass filled polyamide

Degree Of Protection:

IP65 (Washdown)

LED / Noise Suppressor:

Combination LED (Green) and zener diode

Life Expectancy:

30 million operations

Maximum Operating Frequency:

10Hz

Mounting:

35mm (DIN) rail

Operating Medium:

Compressed air

Operating Pressure Range:

45 to 120 PSI (3 to 8 bar)

Operating Principal:

Solenoid pilot operated poppet valve

Operating Temperature Range:

5°F to 140°F (-15°C to 60°C)

Overvoltage Protection:

DC versions are protected up to 300V

Power Consumption:

Hold: DC 1.2W AC 1.6VA

Inrush: DC 1.2W AC 3.5VA

Response Time:

10 - 15 ms @ 90 PSIG

Seal Material:

Poppet - Polyurethane

Seals - Nitrile (Buna N)

Supply and Exhaust Ports:

1/4"

Maximum Allowable Currents:

1000 mA (1 Amp)

Simultaneous Operation:

Some applications require simultaneous use of devices during setup or operation. Under normal single device operation, reliability can be assured by staying within the stated "Maximum Allowable Currents". During simultaneous operation, however, only ten 12VDC solenoids can be operated simultaneously because their total accumulated current = 1000 mA.

Surge Suppression:
Diode for DC version
Varistar for AC version
Tube Connections:

Push-In (instant) fittings 5/32" or 1/4"

Voltage Tolerance:
+10 to -15% of rated voltage
@ 70°F (20° C)

C

Pin Out Detail D-Sub, 25-Pin Connector

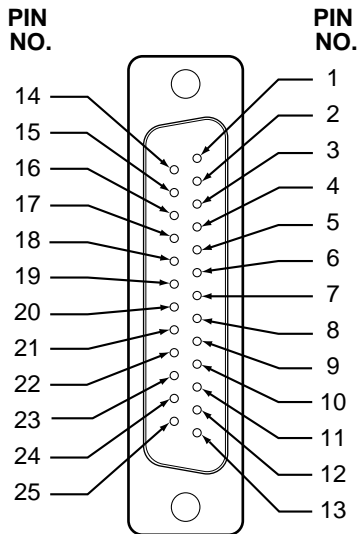

Output Solenoid No.	D-Sub, 25-Pin No.	IP65 Cable Colors
1	13	Green
2	25	Transparent
3	12	Dark Blue
4	24	Light Blue
5	11	Pink
6	23	Purple
7	10	Dark Green / Black
8	22	Yellow
9	9	Light Green / Black
10	21	Yellow / Black
11	8	Blue / Black
12	20	White / Black
13	7	Khaki
14	19	Orange
15	6	White
16	18	Grey
Not Used	5	Red / Black
Not Used	17	Red
Not Used	4	Brown
Valve Common	16	Black

Notes: Solenoids are polarity sensitive. The common must be at OV.
 Switching must be at the high potential.
 Maximum 16 solenoid outputs with one valve (negative) common line on Pin 16.

Cable with Female D-Sub, 25-Pin Connector

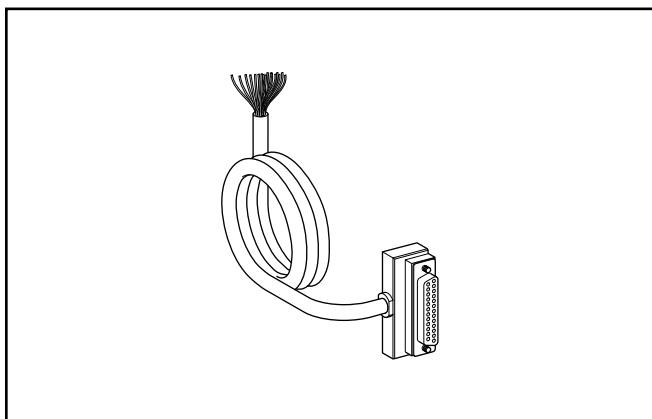

P8L-MD25A5B	5 Meters / 16.40 Ft
--------------------	---------------------

Connection to the control system is through 20 colored wires AWG 24, rated at 2.5 amp. For use with Solstar, Interface 2000, PVLB10 and PVLC10 valves only.

35mm DIN Rail

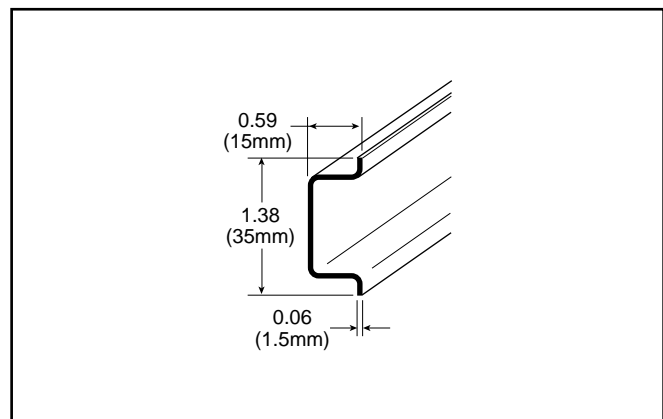

AM1DE200	1.83 Meters / 6.0 Ft
-----------------	----------------------

DIN rail can be mounted to grids or other surfaces to allow snap in mounting of pneumatic and electrical components.



Interface 2000 Manifold with D-Sub, 25-Pin Connector Module

C

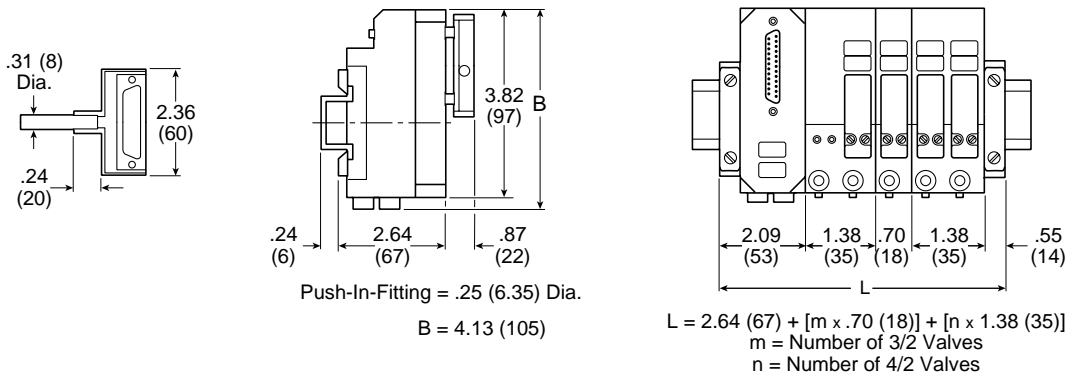

Notes:

1. Sub-D Module shown with 1/4" ports
2. Valves shown with 4mm (5/32") ports.

Intermediate Air Supply Module

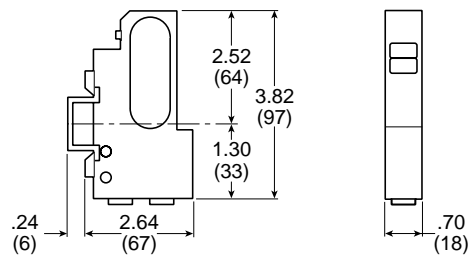



**Global
Pneumatics**

This icon can be found next to products that are widely supported by Parker Pneumatics' worldwide manufacturing and sales network. When you see this icon, you can be confident that this product is manufactured and / or stocked* worldwide for rapid delivery. In addition to local manufacturing or inventory, our sales network has been specifically trained on these products to provide our customers with the best possible service.

Products not showing this icon are still sold and distributed worldwide. However, The Global Pneumatics icon represents products that customers can expect the best level of support.

If you are a multi-national company, seek global sourcing or ship globally, depend on Parker Pneumatic for **PREMIER CUSTOMER SERVICE**.

* Stocking levels vary by country

WARNING

FAILURE OR IMPROPER SELECTION OR IMPROPER USE OF THE PRODUCTS AND/OR SYSTEMS DESCRIBED HEREIN OR RELATED ITEMS CAN CAUSE DEATH, PERSONAL INJURY AND PROPERTY DAMAGE.

This document and other information from Parker Hannifin Corporation, its subsidiaries and authorized distributors provide product and/or system options for further investigation by users having technical expertise. It is important that you analyze all aspects of your application including consequences of any failure, and review the information concerning the product or system in the current product catalog. Due to the variety of operating conditions and applications for these products or systems, the user, through its own analysis and testing, is solely responsible for making the final selection of the products and systems and assuring that all performance, safety and warning requirements of the application are met.

The products described herein, including without limitation, product features, specifications, designs, availability and pricing, are subject to change by Parker Hannifin Corporation and its subsidiaries at any time without notice.

Offer of Sale

The items described in this document are hereby offered for sale by Parker Hannifin Corporation, its subsidiaries or its authorized distributors. This offer and its acceptance are governed by the provisions stated on the separate page of this document entitled "Offer of Sale".

Safety Guide For Selecting And Using Pneumatic Division Products And Related Accessories

WARNING:

FAILURE OR IMPROPER SELECTION OR IMPROPER USE OF PNEUMATIC DIVISION PRODUCTS, ASSEMBLIES OR RELATED ITEMS ("PRODUCTS") CAN CAUSE DEATH, PERSONAL INJURY, AND PROPERTY DAMAGE. POSSIBLE CONSEQUENCES OF FAILURE OR IMPROPER SELECTION OR IMPROPER USE OF THESE PRODUCTS INCLUDE BUT ARE NOT LIMITED TO:

- Unintended or mistimed cycling or motion of machine members or failure to cycle
- Work pieces or component parts being thrown off at high speeds.
- Failure of a device to function properly for example, failure to clamp or unclamp an associated item or device.
- Explosion
- Suddenly moving or falling objects.
- Release of toxic or otherwise injurious liquids or gasses.

Before selecting or using any of these Products, it is important that you read and follow the instructions below.

1. GENERAL INSTRUCTIONS

- 1.1. Scope:** This safety guide is designed to cover general guidelines on the installation, use, and maintenance of Pneumatic Division Valves, FRLs (Filters, Pressure Regulators, and Lubricators), Vacuum products and related accessory components.
- 1.2. Fail-Safe:** Valves, FRLs, Vacuum products and their related components can and do fail without warning for many reasons. Design all systems and equipment in a fail-safe mode, so that failure of associated valves, FRLs or Vacuum products will not endanger persons or property.
- 1.3. Relevant International Standards:** For a good guide to the application of a broad spectrum of pneumatic fluid power devices see: ISO 4414:1998, Pneumatic Fluid Power – General Rules Relating to Systems. See www.iso.org for ordering information.
- 1.4. Distribution:** Provide a copy of this safety guide to each person that is responsible for selection, installation, or use of Valves, FRLs or Vacuum products. Do not select, or use Parker valves, FRLs or vacuum products without thoroughly reading and understanding this safety guide as well as the specific Parker publications for the products considered or selected.
- 1.5. User Responsibility:** Due to the wide variety of operating conditions and applications for valves, FRLs, and vacuum products Parker and its distributors do not represent or warrant that any particular valve, FRL or vacuum product is suitable for any specific end use system. This safety guide does not analyze all technical parameters that must be considered in selecting a product. The user, through its own analysis and testing, is solely responsible for:
 - Making the final selection of the appropriate valve, FRL, Vacuum component, or accessory.
 - Assuring that all user's performance, endurance, maintenance, safety, and warning requirements are met and that the application presents no health or safety hazards.
 - Complying with all existing warning labels and / or providing all appropriate health and safety warnings on the equipment on which the valves, FRLs or Vacuum products are used; and,
 - Assuring compliance with all applicable government and industry standards.
- 1.6. Safety Devices:** Safety devices should not be removed, or defeated.
- 1.7. Warning Labels:** Warning labels should not be removed, painted over or otherwise obscured.
- 1.8. Additional Questions:** Call the appropriate Parker technical service department if you have any questions or require any additional information. See the Parker publication for the product being considered or used, or call 1-800-CPARKER, or go to www.parker.com, for telephone numbers of the appropriate technical service department.

2. PRODUCT SELECTION INSTRUCTIONS

- 2.1. Flow Rate:** The flow rate requirements of a system are frequently the primary consideration when designing any pneumatic system. System components need to be able to provide adequate flow and pressure for the desired application.
- 2.2. Pressure Rating:** Never exceed the rated pressure of a product. Consult product labeling, Pneumatic Division catalogs or the instruction sheets supplied for maximum pressure ratings.
- 2.3. Temperature Rating:** Never exceed the temperature rating of a product. Excessive heat can shorten the life expectancy of a product and result in complete product failure.
- 2.4. Environment:** Many environmental conditions can affect the integrity and suitability of a product for a given application. Pneumatic Division products are designed for use in general purpose industrial applications. If these products are to be used in unusual circumstances such as direct sunlight and/or corrosive or caustic environments, such use can shorten the useful life and lead to premature failure of a product.
- 2.5. Lubrication and Compressor Carryover:** Some modern synthetic oils can and will attack nitrile seals. If there is any possibility of synthetic oils or greases migrating into the pneumatic components check for compatibility with the seal materials used. Consult the factory or product literature for materials of construction.
- 2.6. Polycarbonate Bowls and Sight Glasses:** To avoid potential polycarbonate bowl failures:
 - Do not locate polycarbonate bowls or sight glasses in areas where they could be subject to direct sunlight, impact blow, or temperatures outside of the rated range.
 - Do not expose or clean polycarbonate bowls with detergents, chlorinated hydro-carbons, ketones, esters or certain alcohols.
 - Do not use polycarbonate bowls or sight glasses in air systems where compressors are lubricated with fire resistant fluids such as phosphate ester and di-ester lubricants.

2.7. Chemical Compatibility: For more information on plastic component chemical compatibility see Pneumatic Division technical bulletins Tec-3, Tec-4, and Tec-5

2.8. Product Rupture: Product rupture can cause death, serious personal injury, and property damage.

- Do not connect pressure regulators or other Pneumatic Division products to bottled gas cylinders.
- Do not exceed the maximum primary pressure rating of any pressure regulator or any system component.
- Consult product labeling or product literature for pressure rating limitations.

3. PRODUCT ASSEMBLY AND INSTALLATION INSTRUCTIONS

3.1. Component Inspection: Prior to assembly or installation a careful examination of the valves, FRLs or vacuum products must be performed. All components must be checked for correct style, size, and catalog number. DO NOT use any component that displays any signs of nonconformance.

3.2. Installation Instructions: Parker published Installation Instructions must be followed for installation of Parker valves, FRLs and vacuum components. These instructions are provided with every Parker valve or FRL sold, or by calling 1-800-CPARKER, or at www.parker.com.

3.3. Air Supply: The air supply or control medium supplied to Valves, FRLs and Vacuum components must be moisture-free if ambient temperature can drop below freezing

4. VALVE AND FRL MAINTENANCE AND REPLACEMENT INSTRUCTIONS

4.1. Maintenance: Even with proper selection and installation, valve, FRL and vacuum products service life may be significantly reduced without a continuing maintenance program. The severity of the application, risk potential from a component failure, and experience with any known failures in the application or in similar applications should determine the frequency of inspections and the servicing or replacement of Pneumatic Division products so that products are replaced before any failure occurs. A maintenance program must be established and followed by the user and, at minimum, must include instructions 4.2 through 4.10.

4.2. Installation and Service Instructions: Before attempting to service or replace any worn or damaged parts consult the appropriate Service Bulletin for the valve or FRL in question for the appropriate practices to service the unit in question. These Service and Installation Instructions are provided with every Parker valve and FRL sold, or are available by calling 1-800-CPARKER, or by accessing the Parker web site at www.parker.com.

4.3. Lockout / Tagout Procedures: Be sure to follow all required lockout and tagout procedures when servicing equipment. For more information see: OSHA Standard – 29 CFR, Part 1910.147, Appendix A, The Control of Hazardous Energy – (Lockout / Tagout)

4.4. Visual Inspection: Any of the following conditions requires immediate system shut down and replacement of worn or damaged components:

- Air leakage: Look and listen to see if there are any signs of visual damage to any of the components in the system. Leakage is an indication of worn or damaged components.
- Damaged or degraded components: Look to see if there are any visible signs of wear or component degradation.
- Kinked, crushed, or damaged hoses. Kinked hoses can result in restricted air flow and lead to unpredictable system behavior.
- Any observed improper system or component function: Immediately shut down the system and correct malfunction.
- Excessive dirt build-up: Dirt and clutter can mask potentially hazardous situations.

Caution: Leak detection solutions should be rinsed off after use.

4.5. Routine Maintenance Issues:

- Remove excessive dirt, grime and clutter from work areas.
- Make sure all required guards and shields are in place.

4.6. Functional Test: Before initiating automatic operation, operate the system manually to make sure all required functions operate properly and safely.

4.7. Service or Replacement Intervals: It is the user's responsibility to establish appropriate service intervals. Valves, FRLs and vacuum products contain components that age, harden, wear, and otherwise deteriorate over time. Environmental conditions can significantly accelerate this process. Valves, FRLs and vacuum components need to be serviced or replaced on routine intervals. Service intervals need to be established based on:

- Previous performance experiences.
- Government and / or industrial standards.
- When failures could result in unacceptable down time, equipment damage or personal injury risk.

4.8. Servicing or Replacing of any Worn or Damaged Parts: To avoid unpredictable system behavior that can cause death, personal injury and property damage:

- Follow all government, state and local safety and servicing practices prior to service including but not limited to all OSHA Lockout Tagout procedures (OSHA Standard – 29 CFR, Part 1910.147, Appendix A, The Control of Hazardous Energy – Lockout / Tagout).
- Disconnect electrical supply (when necessary) before installation, servicing, or conversion.
- Disconnect air supply and depressurize all air lines connected to system and Pneumatic Division products before installation, service, or conversion.
- Installation, servicing, and / or conversion of these products must be performed by knowledgeable personnel who understand how pneumatic products are to be applied.
- After installation, servicing, or conversions air and electrical supplies (when necessary) should be connected and the product tested for proper function and leakage. If audible leakage is present, or if the product does not operate properly, do not put product or system into use.
- Warnings and specifications on the product should not be covered or painted over. If masking is not possible, contact your local representative for replacement labels.

4.9. Putting Serviced System Back into Operation: Follow the guidelines above and all relevant Installation and Maintenance Instructions supplied with the valve FRL or vacuum component to insure proper function of the system.

Offer of Sale

The items described in this document and other documents or descriptions provided by Parker Hannifin Corporation, its subsidiaries and its authorized distributors, are hereby offered for sale at prices to be established by Parker Hannifin Corporation, its subsidiaries and its authorized distributors. This offer and its acceptance by any customer ("Buyer") shall be governed by all of the following Terms and Conditions. Buyer's order for any such item, when communicated to Parker Hannifin Corporation, its subsidiaries or an authorized distributor ("Seller") verbally or in writing, shall constitute acceptance of this offer.

1. Terms and Conditions of Sale: All descriptions, quotations, proposals, offers, acknowledgments, acceptances and sales of Seller's products are subject to and shall be governed exclusively by the terms and conditions stated herein. Buyer's acceptance of any offer to sell is limited to these terms and conditions. Any terms or conditions in addition to, or inconsistent with those stated herein, proposed by Buyer in any acceptance of an offer by Seller, are hereby objected to. No such additional, different or inconsistent terms and conditions shall become part of the contract between Buyer and Seller unless expressly accepted in writing by Seller. Seller's acceptance of any offer to purchase by Buyer is expressly conditional upon Buyer's assent to all the terms and conditions stated herein, including any terms in addition to, or inconsistent with those contained in Buyer's offer. Acceptance of Seller's products shall in all events constitute such assent.

2. Payment: Payment shall be made by Buyer net 30 days from the date of delivery of the items purchased hereunder. Amounts not timely paid shall bear interest at the maximum rate permitted by law for each month or portion thereof that the Buyer is late in making payment. Any claims by Buyer for omissions or shortages in a shipment shall be waived unless Seller receives notice thereof within 30 days after Buyer's receipt of the shipment.

3. Delivery: Unless otherwise provided on the face hereof, delivery shall be made F.O.B. Seller's plant. Regardless of the method of delivery, however, risk of loss shall pass to Buyer upon Seller's delivery to a carrier. Any delivery dates shown are approximate only and Seller shall have no liability for any delays in delivery.

4. Warranty: Seller warrants that the items sold hereunder shall be free from defects in material or workmanship for a period of 18 months from date of shipment from Parker Hannifin Corporation. THIS WARRANTY COMPRISES THE SOLE AND ENTIRE WARRANTY PERTAINING TO ITEMS PROVIDED HEREUNDER. SELLER MAKES NO OTHER WARRANTY, GUARANTEE, OR REPRESENTATION OF ANY KIND WHATSOEVER. ALL OTHER WARRANTIES, INCLUDING BUT NOT LIMITED TO, MERCHANTABILITY AND FITNESS FOR PURPOSE, WHETHER EXPRESS, IMPLIED, OR ARISING BY OPERATION OF LAW, TRADE USAGE, OR COURSE OF DEALING ARE HEREBY DISCLAIMED.

NOTWITHSTANDING THE FOREGOING, THERE ARE NOWARRANTIES WHATSOEVER ON ITEMS BUILT OR ACQUIRED WHOLLY OR PARTIALLY, TO BUYER'S DESIGN OR SPECIFICATIONS.

5. Limitation of Remedy: SELLER'S LIABILITY ARISING FROM OR IN ANY WAY CONNECTED WITH THE ITEMS SOLD OR THIS CONTRACT SHALL BE LIMITED EXCLUSIVELY TO REPAIR OR REPLACEMENT OF THE ITEMS SOLD OR REFUND OF THE PURCHASE PRICE PAID BY BUYER, AT SELLER'S SOLE OPTION. IN NO EVENT SHALL SELLER BE LIABLE FOR ANY INCIDENTAL, CONSEQUENTIAL OR SPECIAL DAMAGES OF ANY KIND OR NATURE WHATSOEVER, INCLUDING BUT NOT LIMITED TO LOST PROFITS ARISING FROM OR IN ANY WAY CONNECTED WITH THIS AGREEMENT OR ITEMS SOLD HEREUNDER, WHETHER ALLEGED TO ARISE FROM BREACH OF CONTRACT, EXPRESS OR IMPLIED WARRANTY, OR IN TORT, INCLUDING WITHOUT LIMITATION, NEGLIGENCE, FAILURE TO WARN OR STRICT LIABILITY.

6. Changes, Reschedules and Cancellations: Buyer may request to modify the designs or specifications for the items sold hereunder as well as the quantities and delivery dates thereof, or may request to cancel all or part of this order, however, no such requested modification or cancellation shall become part of the contract between Buyer and Seller unless accepted by Seller in a written amendment to this Agreement. Acceptance of any such requested modification or cancellation shall be at Seller's discretion, and shall be upon such terms and conditions as Seller may require.

7. Special Tooling: A tooling charge may be imposed for any special tooling, including without limitations, dies, fixtures, molds and patterns, acquired to manufacture items sold pursuant to this contract. Such special tooling shall be and remain Seller's property notwithstanding payment of any charges by Buyer. In no event will Buyer acquire any interest in apparatus belonging to Seller which is utilized in the manufacture of the items sold hereunder, even if such apparatus has been specially converted or adapted for such manufacture and notwithstanding any

charges paid by Buyer. Unless otherwise agreed, Seller shall have the right to alter, discard or otherwise dispose of any special tooling or other property in its sole discretion at any time.

8. Buyer's Property: Any designs, tools, patterns, materials, drawings, confidential information or equipment furnished by Buyer, or any other items which become Buyer's property, may be considered obsolete and may be destroyed by Seller after two (2) consecutive years have elapsed without Buyer placing an order for the items which are manufactured using such property. Seller shall not be responsible for any loss or damage to such property while it is in Seller's possession or control.

9. Taxes: Unless otherwise indicated on the face hereof, all prices and charges are exclusive of excise, sales, use, property, occupational or like taxes which may be imposed by any taxing authority upon the manufacture, sale or delivery of the items sold hereunder. If any such taxes must be paid by Seller or if Seller is liable for the collection of such tax, the amount thereof shall be in addition to the amounts for the items sold. Buyer agrees to pay all such taxes or to reimburse Seller therefore upon receipt of its invoice. If Buyer claims exemption from any sales, use or other tax imposed by any taxing authority, Buyer shall save Seller harmless from and against any such tax, together with any interest or penalties thereon which may be assessed if the items are held to be taxable.

10. Indemnity For Infringement of Intellectual Property Rights: Seller shall have no liability for infringement of any patents, trademarks, copyrights, trade dress, trade secrets or similar rights except as provided in this Part 10. Seller will defend and indemnify Buyer against allegations of infringement of U.S. patents, U.S. trademarks, copyrights, trade dress and trade secrets (hereinafter "Intellectual Property Rights"). Seller will defend at its expense and will pay the cost of any settlement or damages awarded in an action brought against Buyer based on an allegation that an item sold pursuant to this contract infringes the Intellectual Property Rights of a third party. Seller's obligation to defend and indemnify Buyer is contingent on Buyer notifying Seller within ten (10) days after Buyer becomes aware of such allegations of infringement, and Seller having sole control over the defense of any allegations or actions including all negotiations for settlement or compromise. If an item sold hereunder is subject to a claim that it infringes the Intellectual Property Rights of a third party, Seller may, at its sole expense and option, procure for Buyer the right to continue using said item, replace or modify said item so as to make it noninfringing, or offer to accept return of said item and return the purchase price less a reasonable allowance for depreciation. Notwithstanding the foregoing, Seller shall have no liability for claims of infringement based on information provided by Buyer, or directed to items delivered hereunder for which the designs are specified in whole or part by Buyer, or infringements resulting from the modification, combination or use in a system of any item sold hereunder. The foregoing provisions of this Part 10 shall constitute Seller's sole and exclusive liability and Buyer's sole and exclusive remedy for infringement of Intellectual Property Rights.

If a claim is based on information provided by Buyer or if the design for an item delivered hereunder is specified in whole or in part by Buyer, Buyer shall defend and indemnify Seller for all costs, expenses or judgments resulting from any claim that such item infringes any patent, trademark, copyright, trade dress, trade secret or any similar right.

11. Force Majeure: Seller does not assume the risk of and shall not be liable for delay or failure to perform any of Seller's obligations by reason of circumstances beyond the reasonable control of Seller (hereinafter "Events of Force Majeure"). Events of Force Majeure shall include without limitation, accidents, acts of God, strikes or labor disputes, acts, laws, rules or regulations of any government or government agency, fires, floods, delays or failures in delivery of carriers or suppliers, shortages of materials and any other cause beyond Seller's control.

12. Entire Agreement/Governing Law: The terms and conditions set forth herein, together with any amendments, modifications and any different terms or conditions expressly accepted by Seller in writing, shall constitute the entire Agreement concerning the items sold, and there are no oral or other representations or agreements which pertain thereto. This Agreement shall be governed in all respects by the law of the State of Ohio. No actions arising out of sale of the items sold hereunder or this Agreement may be brought by either party more than two (2) years after the cause of action accrues.

Y

