



# 1025D Foot & Palm Switch Service Bulletin

## Mushroom Button - Foot or Palm Operation

### Description

This foot and palm-operated switch may be equipped with either one or two precision unit switches. Each precision switch has one single pole double break double throw circuit.

### Installation

This switch may be mounted in any convenient position. Remove the "button" cover (item 7) by removing the center nameplate screw and lockwasher (item 9), and washer (item 8). Pull the button and diaphragm off the switch case. The precision unit switch has letters "A" and "B" on the molding. Refer to the circuit symbols shown on the label inside the cover. The symbols show the foot switch in the normal position. When the button is depressed, the "A" circuit is closed. The wiring connections within each precision unit switch must be the same polarity.

Reassemble the button cover so that the rib openings in the inside center of the cover engage the cross bar. Depress and rotate the cover back and forth slightly to help the diaphragm seat itself on the rim of the case. Install the felt washer, lockwasher, and nameplate screw.

### Lubrication

The mechanical parts were lubricated at the factory when assembled, and it should not be necessary to relubricate.

### Renewal Parts

When ordering Renewal Parts, give

reference to this Form No. 532, Item No., Description, Quantity, Part No. and the complete Number stamped on the nameplate.

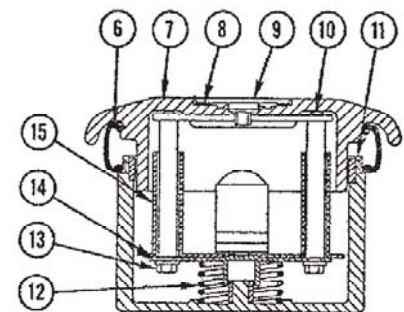
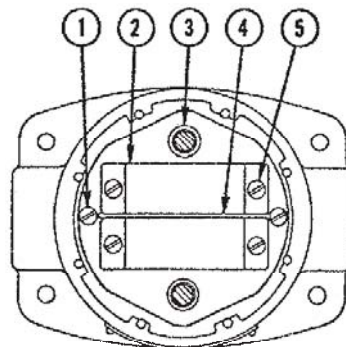

Renewal Parts			
Item No.	Description of Part	No. Req.	Part No.
1	Screw Rd Hd Mach 6-32 X 1/4" W / Sems Washer	2	04560054
2a	Switch - SPDT	As Req.	19501BADO
2b	Switch - DPDT	As Req.	19504BADO
3	Insulator	2	M0652000
4	Insulator (Required when two switches are used)	1	S0070100
5	Screw Pan Hd Mach 6-32 X 5/8" W / Sems Washer	As Req.	04560058
6	Diaphragm	1	P0078600
7	Button	1	A0054700
8	Felt Washer	1	S0069900
9	Indicating plate and cover screw	As Req.	
	STOP	*	NP0097002
	START	*	NP0097001
	BLANK PLATE	*	NP0097000
10	Plate and Post Assembly	1	SD0316600
11	Case	1	A0054600
12	Spring	1	04581005
13	Hex Nut #10-32	2	04562017
	Lock washer #10	2	04563031
14	Spring Plate	1	SD0316700
15	Plate and Bushing Assembly	1	SD0317000

# 1025D Foot & Palm Switch

## Dimension Drawing

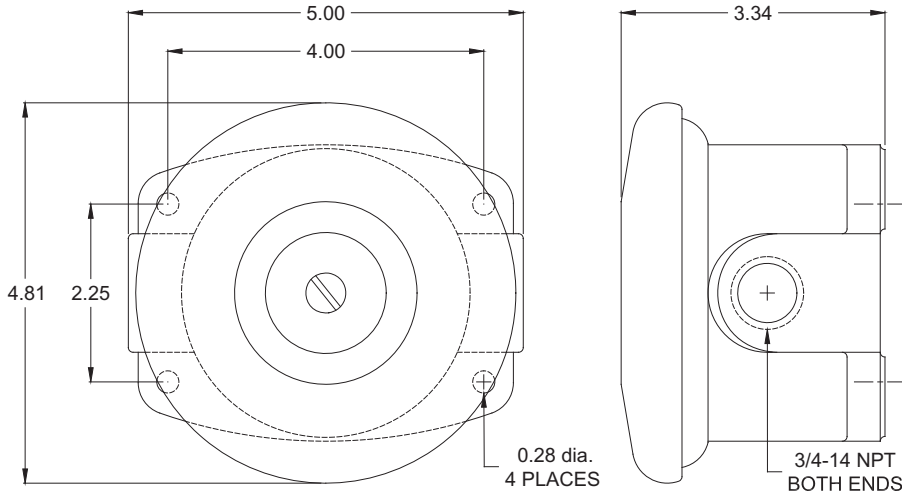



**OPERATOR WARNING**

THIS FOOT SWITCH SHOULD ONLY BE USED WHERE POINT OF OPERATION GUARDING DEVICES HAVE BEEN PROPERLY INSTALLED SO THAT IT IS IMPOSSIBLE FOR THE OPERATOR'S HANDS OR FINGERS TO REMAIN WITHIN THE POINT OF OPERATION DURING THE ACTUAL MACHINE CYCLE.

OSHA REGULATIONS (STANDARDS 29 CFR - 1910)  
NP-0096900

### SPDT SINGLE POLE DOUBLE THROW

FILE E56660  
CCN NKCR2

### DPDT DOUBLE POLE DOUBLE THROW

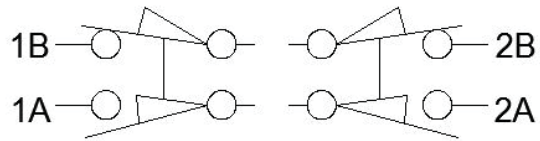
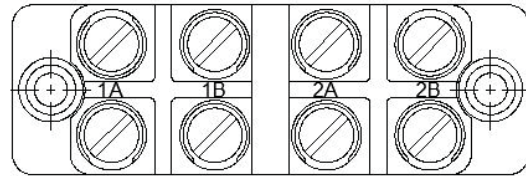
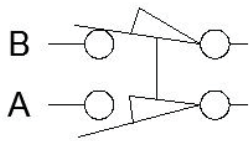
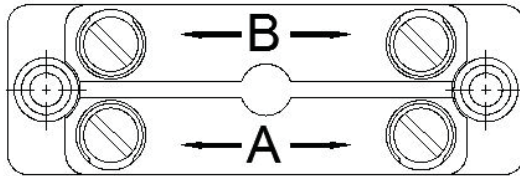

### CONTACT RATINGS AMPERES

AC Pilot Duty			DC Pilot Duty	
Volts	Make	Break	Volts	Make/Break
110	40	15	115	0.25
220	20	10	230	0.10
440	10	6	600	.....
600	8	5		

### CONTACT RATINGS AMPERES

AC Pilot Duty			DC Pilot Duty	
Volts	Make	Break	Volts	Make/Break
115	30	3	115	0.2
230	15	1.5	230	0.1
440	7.5	.75	600	.....
575	6	.60		

## APPLICATION NOTE

- 1) The N.O. and N.C. contacts of the SPDT snap switch must be used on circuits of the same polarity.
- 2) The DPDT snap switch has (2) two electrically separate poles, which can be used on opposite polarities. The N.O. and N.C. circuit of each pole of the DPDT snap switch, however, must be used on the same polarity.