



COMPAX-M/S

Compact Servo Controller

Catalogue 192-040011 N18 / UK
Version 18 / April 2001



Contents

COMPAX compact servo controller	4
COMPAX application examples	5
COMPAX - modern control technology	6
System features.....	7
COMPAX - family	8
COMPAX 1000SL.....	8
COMPAX 25XXS	9
COMPAX 45XXS/85XXS	10
COMPAX-M	11
COMPAX 35XXM.....	13
Accessories / options	14
Software tools.....	14
Operating panels	14
Hand-held terminal.....	14
HEDA interface (Option A1/A4)	14
Parker servomotors	14
EMC measures	15
AC surge filter.....	15
Motor output filter	16
External ballast resistors.....	17
COMPAX software variants	18
COMPAX XX30: round table control.....	18
COMPAX XX50: synchronous cycle control.....	19
COMPAX XX60: electronic gearbox.....	20
COMPAX XX70: electronic cam control	21
Technical data	25
COMPAX order code	28
Order code for accessories	29

COMPAX compact servo controller

- Positioning control and servo amplifier in one unit -

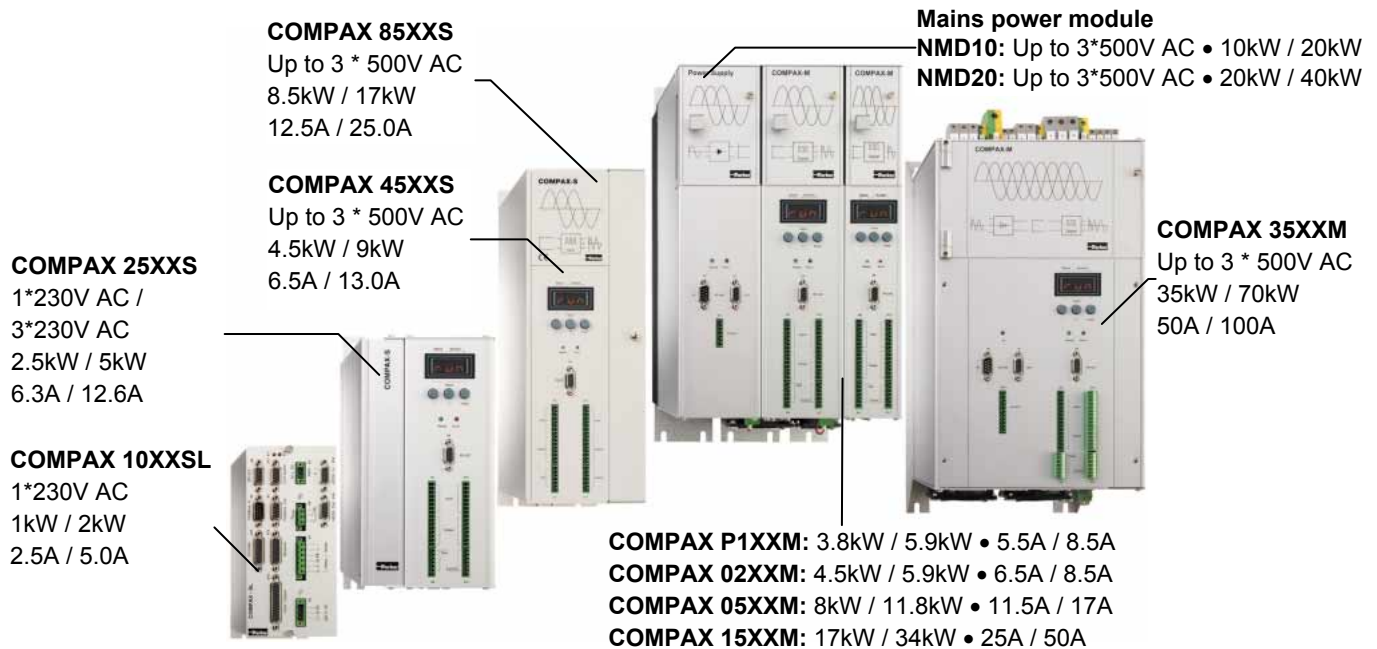

The COMPAX family

Nominal data / peak data

The COMPAX compact servo controller ...

integrates the following functions into one single device:

- Operation of synchronous and asynchronous motors.
- Operation of 3-phase synchronous linear motors.
- Control of motion and peripherals
- Closed loop control of speed / power / position.
- Power output stages:
1.0kW to 35kW
- Communication via several interfaces
- Power input:
 - from central power unit, or
 - directly from 230V AC or up to 500V AC
- Program memory with 250 data locations

The hardware does not need to be changed when using different motor types - digitally set parameter values are simply re-programmed.

Typical fields of application ...

Examples of the applications for this advanced technology are:

- **Assembly systems** e.g. rotary tables, continuous assembly conveyors
- **Special-purpose machines** e.g. dosing units, electronic gearboxes
- **Handling systems** e.g. palletising, feeding, removal
- **Machine tools** e.g. tool positioning, synchronous machining, tool drive
- **Textile machines** e.g. material covering, cutting & sewing
- **Packaging machines** e.g. roller feed, electronic cams, main drives
- **Production machinery** e.g. flying saws, coiling, rotating cutters
- **Measuring and testing** e.g. sensor positioning, continuous path control.

The control technology...

of COMPAX compact servo control units offer the following advantages over separate hardware for position, speed and torque control:

- rapid, simple and safe parameter setting and start-up
- fast and stable control direct from the factory
- low peak torque requirements and better tracking characteristics (reduced following error)
- only two independent optimisation parameters for the three control loops
- central digital control of all components from the power output stage to the set point generator
- less cabling with reduced susceptibility to faults.

Subject to technical change. Data represents the technical status at the time of closing the press.

COMPAX application examples

Transverse stop adjustment in material feed

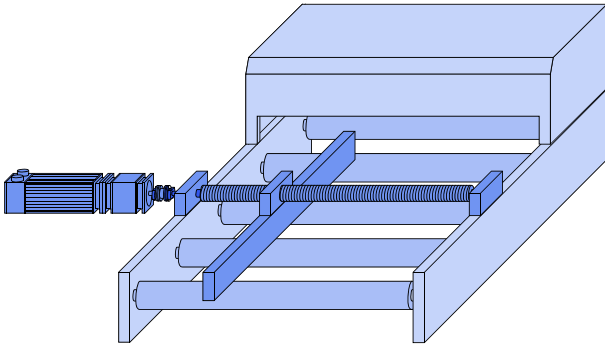

Gantry robots

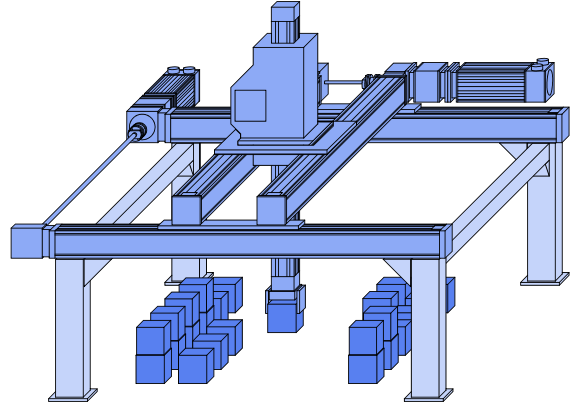

Longitudinal stop adjustment

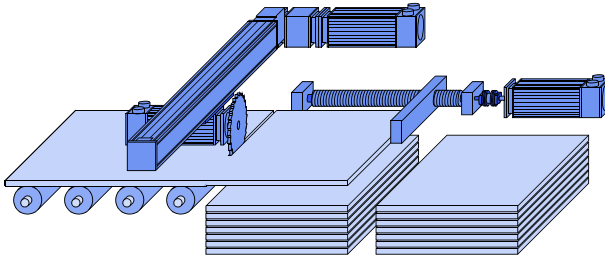

Rolling out films

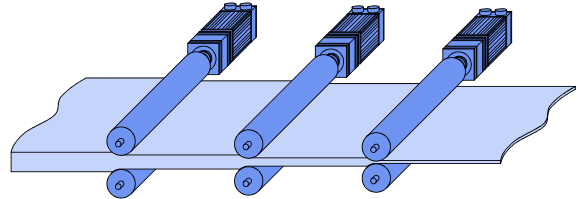

Angled beam saw

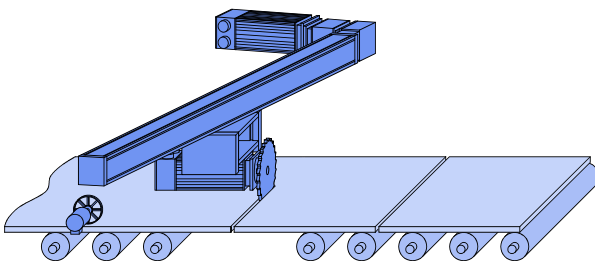

Mark-related cutting to size

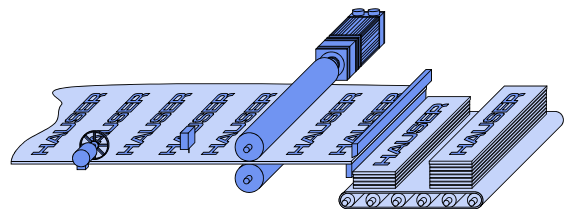

Processing while in motion

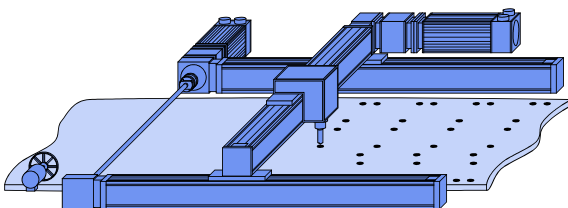

Electronic cam control

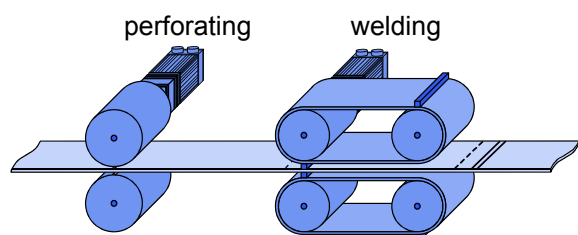

COMPAX - modern control technology ...

Equipment technology for decentralised motion tasks

COMPAX has access to all system-related parameters, such as motor type, intermediate circuit voltage, motor currents, external moment of inertias, output stage temperature etc. Automatic control parameter setting and the application of progressive control concepts such as monitor control and adaptive control are only possible once these parameters have been accessed. The information obtained by integrating motion control and the entire control system into one unit is used for fine tuning between closed loop and open loop elements of the control system. This leads to increased dynamic performance and greater stability with reduced peak currents and torques. A special signal processor uses a cycle time of 100 microseconds to ensure rapid closed loop control. As a result, the drive unit has the best possible servo characteristics with regard to dynamic performance, stiffness and the peak torque available.

Fast and stable

is a perfect description of the guiding principle employed in all Parker Hannifin, Electromechanical Division digital controllers. The intelligence of our controllers avoids the costly and time-consuming problems often experienced when starting up and configuring a servo drive. Users will find that the experience and knowledge gained from 30 years of practical work in the drive control field have been implemented in the hardware and software used in the digital COMPAX servo controllers. Users no longer need to have a lot of experience of control systems. Modern methods, such as monitor and adaptive closed loop control are used by Parker Hannifin, Electromechanical Division to continue improving the performance and options available on servo-controllers.

Automatic control parameter setting

All the data needed to set the controller, such as external moments of inertia, motor type, transmission ratio etc., is entered directly in the servo control unit. The intelligent servo control unit automatically calculates the optimum controller parameters. When first activated, all control loops operate in a fast and stable manner straight away. A large number of parameters no longer have to be compared using a process intensive both in terms of time and practical knowledge. The automatic control parameter setting process considerably reduces the number of controller parameters requiring setting.

At the most, only two unrelated optimisation parameters (damping / rigidity) still have to be adapted to the relevant application.

Project planning and starting up a servo control unit

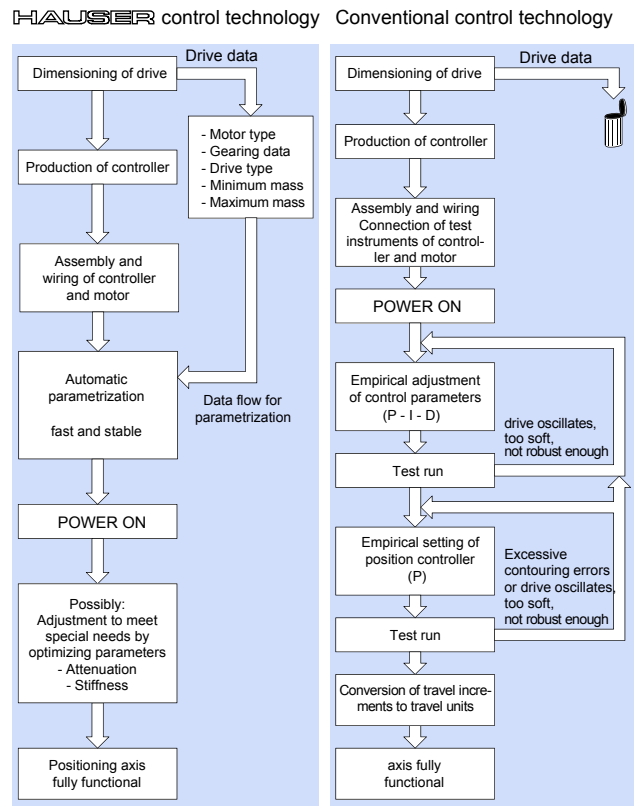

Digital closed loop control

Power, speed and position are controlled by COMPAX in a totally digital manner. Digital signal processors (DSPs) impressively satisfy the requirement for computing capacity needed for software algorithms. The DSP is the technically highly developed, universal platform required to implement functions such as nominal value generation, synchronisation, slip compensation, fine interpolation as well as rapid motion programs. The digital signal processor forms the "heart" and the "main switching unit" of modern servo control units. Increasing computing output and memory sizes ensure transparency for future trends and further developments. The Parker Hannifin, Electromechanical Division, has been implementing the flexible access periphery for over ten years using specific ASIC. Today, DSP and ASIC provide the conceptual basis for the most efficient solution in terms of control quality and the most favoured solution in terms cost. Other advantages of purely digital closed loop control:

- no analogue operating element, i.e. no drift.
- reproducible controller parameters, since these are stored digitally.
- customer-specific modifications can be made to the software

System features

The benefits

When using integrated process control in the compact COMPAX servo control unit, the superordinate process control unit is relieved of all motion-related control tasks. Many applications allow for standalone operation. Using compact servo control units reduces the costs and complexity of superordinate control systems. Considerable savings can be made in the cabling as well as the control cabinet. The machine can be started up faster and in a considerably simpler manner.

Open communication

Parker Hannifin Electromechanical Division provides engagement of the servo control unit by all leading field bus systems. A motion bus as well as inputs and outputs also form part of the goods available, as do visual display elements:

- RS232 (interface for parameter setting and open loop control).
- HEDA – real time input bus
- Interbus S
- Profibus DP and FMS (supported by Simatic® S7 – module)
- CAN bus / CANopen
- CS31 - system bus
- 16 (8) binary inputs and outputs for status and program control
- Universal programmable controller data interface via binary inputs and outputs
- 3-digit, 7-segment display for error and status information (not available with the COMPAX 1000SL) and LED status display

The control system

in the basic COMPAX unit is designed perfectly for the technical control requirements of a servo axis. Special control commands are implemented in the various unit variants for synchroniser or gearbox functions.

Up to 250 structured motion commands can be saved in the internal program memory. The open loop control of the program procedure can be influenced via serial interface or binary I/O's.

The structure of the order commands has been kept simple and is based on the well-known programming language BASIC. Program control instructions, comparator functions, setting / resetting outputs and mo-

tion-related commands for specifying the speed, position, acceleration, etc. are all available. For more information, see the following sample program:

1:	ACCEL 250	Acceleration time 250ms
2:	SPEED 80	Velocity 80%
3:	P010=P040*2.75	Multiplication
4:	P005=P005/2	Division with parameter assignment
5:	V002=P041+20	Addition with parameter
6:	V001=S1+17	Addition with status and variable assignment
7:	REPEAT 10	Conditional wait loop 1s
8:	IF E7=1 GOTO 13	Check if input E7 is at logic 1
9:	WAIT 100	Wait time 100ms
10:	END	End of REPEAT loop
11:	OUTPUT A7=1	Set output; no positioning
12:	GOTO 17	
13:	POSA 1250	Positioning
14:	OUTPUT A8=1	Turn on output A8 for 500 ms
15:	WAIT 500	
16:	OUTPUT A8=0	
17:	END	

All commands are processed in sequence (sequential programming). Program implementation can be broken off (interrupt) at any time via the "Break" signal. The axis is braked using with deceleration time set. The program can be continued from another point.

Position recording

Rotational and linear synchronous and asynchronous motors are supported. The following systems are used for position recording:

- Resolver (standard).
- Sine-cosine sensor (single turn; multi-turn)
Option S1 or with programmable reset route option S2.

The following are also supported:

- Linear servo motors with sine-cosine sensors combined with Hall effect sensors for commutation (COMPAX – option S3).

If there are angle deviations between the motor and load (slip), the load position can also be recorded via an external encoder for optional correction.

COMPAX - family

Housing technology:

The housing and heat sink are designed to prevent the following 3 major problems occurring in the servo drive and control system.

- ◆ The fully-enclosed metal housing provides shielding against electromagnetic interference
- ◆ The generously proportioned heat sink prevents overheating and increases service life
- ◆ Large surface contact with the rear panel provides good high frequency grounding

COMPAX 1000SL

Connector assignment

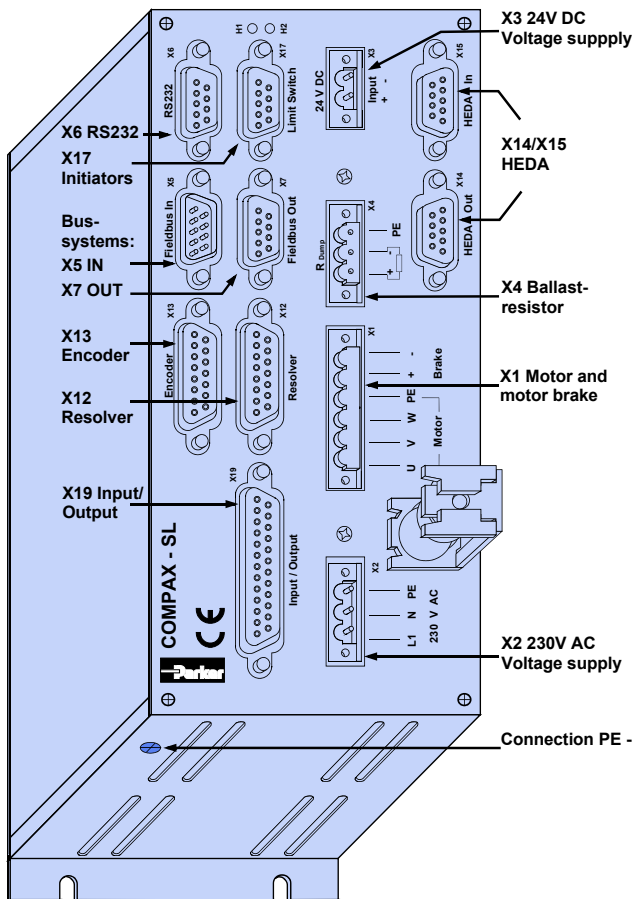

Output data

Device COMPAX ..	Nominal current [Aeff]	Peak current [Aeff] <5s	Power [kVA]
10XXSL	2.5	5	1

Power supply (limit values)

- 1*100V AC-1*250V AC; 45-65Hz
 Typical AC mains: 230V ±10%

Regeneration mode

- Storable energy: 660µF/17Ws
- External ballast resistance: 100Ω / 60W continuous / 253W for >1s (10s cooling period)
 For external ballast resistors, refer to page 16.

Installation and dimensions

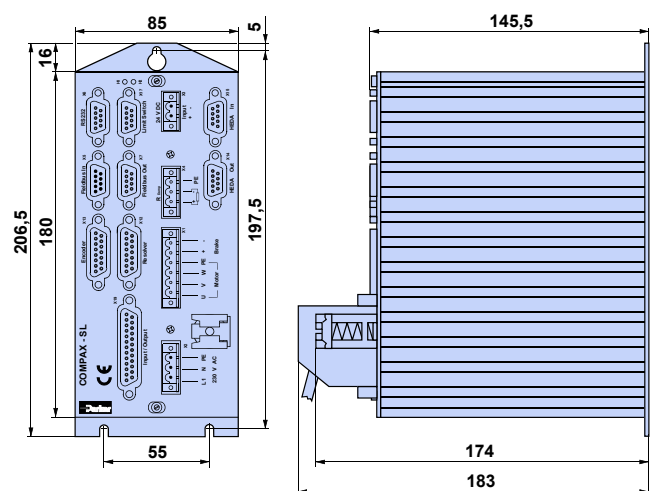

Fastening: 3 M4 Allen screws
 Installation distance: 100mm

COMPAX 25XXS

Connector assignment

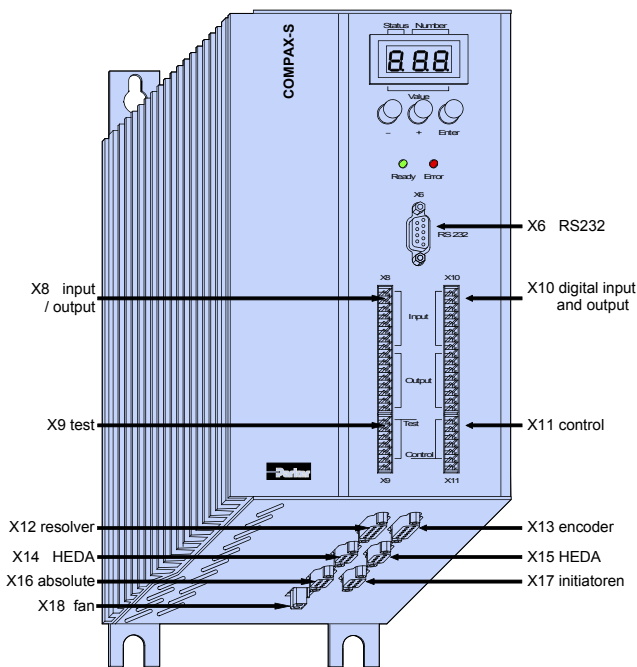

Plan view:

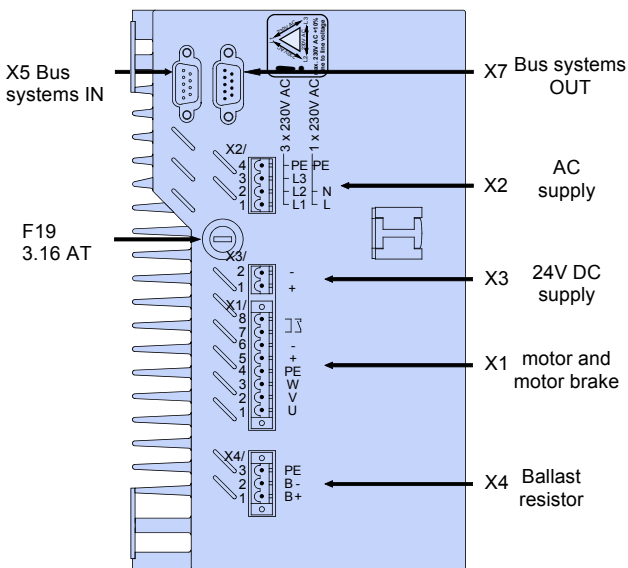

Output data

Device	Nominal current [Aeff]	Peak current [Aeff] <5s	Power [kVA]
COMPAX ..			
at mains supply: 230V AC			
25XXS	6.3	12.6	2.5

Power supply (limit values)

- 3*80V AC - 3*250V AC; 45 - 65 Hz
- 1*100V AC-1*250V AC; 45-65Hz
- Typical AC mains: 1(3) * 230V ±10%

Regeneration mode

- Storable energy: 1100µF/27 Ws
 - External ballast resistance: 56Ω / 180W
- For external ballast resistors, refer to page 16.

Installation and dimensions

The two retaining plates supplied can optionally be attached onto the back or the heat sink side.

Side by side mounting

The left-hand side of the heat sink is fastened to the unit. This is fastened to a metal wall using 2 retaining plates.

Status when delivered:

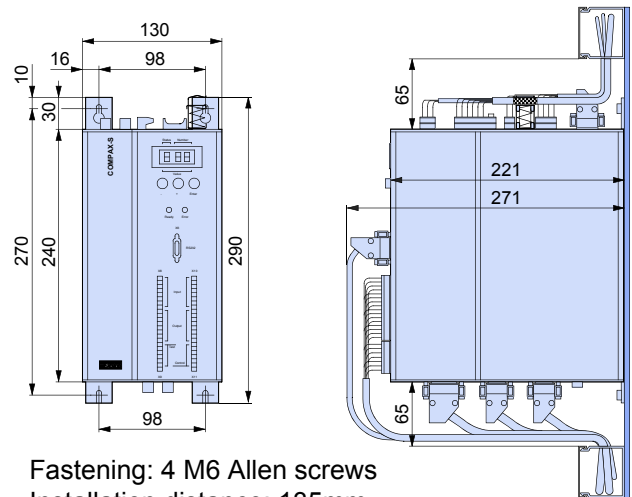

Fastening: 4 M6 Allen screws
 Installation distance: 135mm

Flat design by converting front flange mountings

The left-hand side of the heat sink is fastened to the unit. It is fastened to a metal wall using 2 retaining plates.

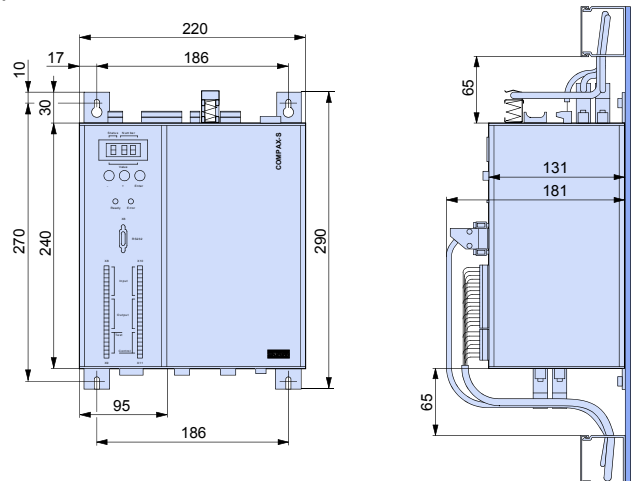

COMPAX 45XXS/85XXS

Connector assignment

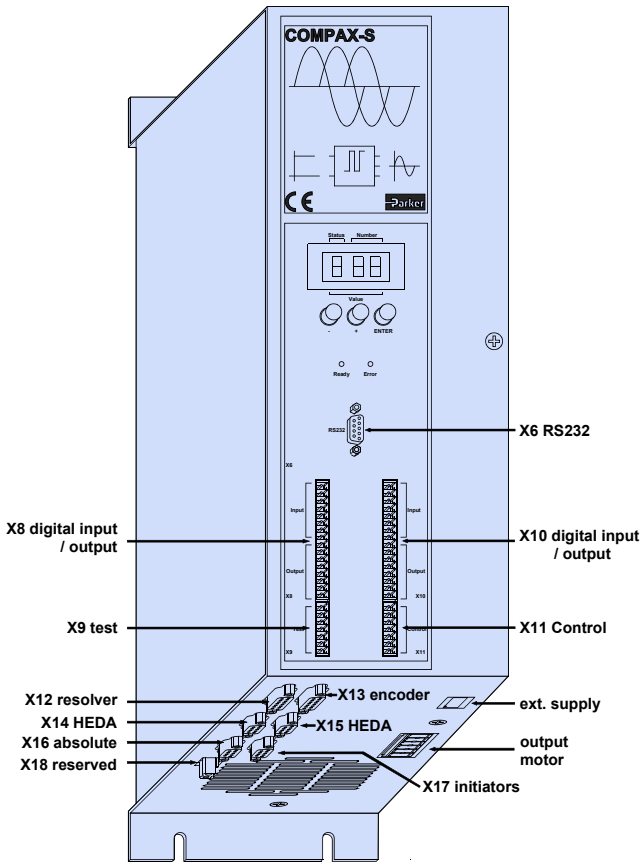

Plan view COMPAX 45XXS / 85XXS

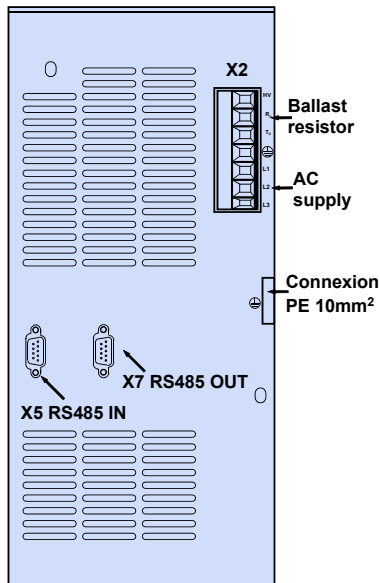

Installation and dimensions

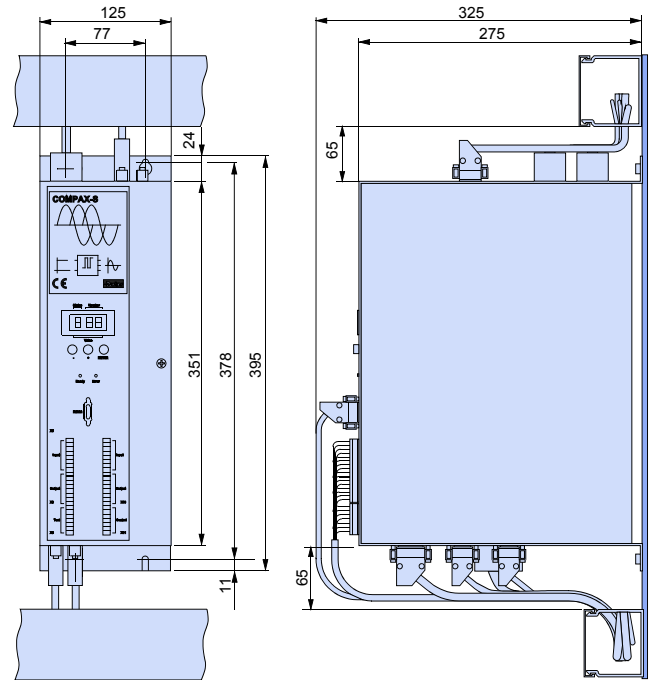

Fastening: 4 M5 Allen screws
 Installation distance: 135mm

Output data for individual units

Device COMPAX ..	Nominal current [Aeff]	Peak current [Aeff] <5s	Power [kVA]
at mains supply: 400V AC			
45XXS	6.5	13.0	4.5
85XXS	12.5	25.0	8.6
at mains supply: 460V AC			
45XXS	5.4	13.0	4.5
85XXS	10.5	25.0	8.6

Power supply (limit values)

- 3*80V AC - 3*500V AC; 45-65Hz.
 Typical AC mains: 400V ±10%; 460V ±10%; 480V ±5%.

Regeneration mode

- Storable energy:
 COMPAX 45XXS: 330µF / 52Ws
 COMPAX 85XXS: 500µF/80 Ws
- Internal ballast resistor: 300W continuous/3kW for <1s (20s cooling time).
- External ballast resistance: 22Ω/450W
 For the external ballast resistors available, please refer to page 16.

COMPAX-M

(COMPAX P1XXM, COMPAX 02XXM, COMPAX 05XXM, COMPAX 15XXM)

Connector assignment.

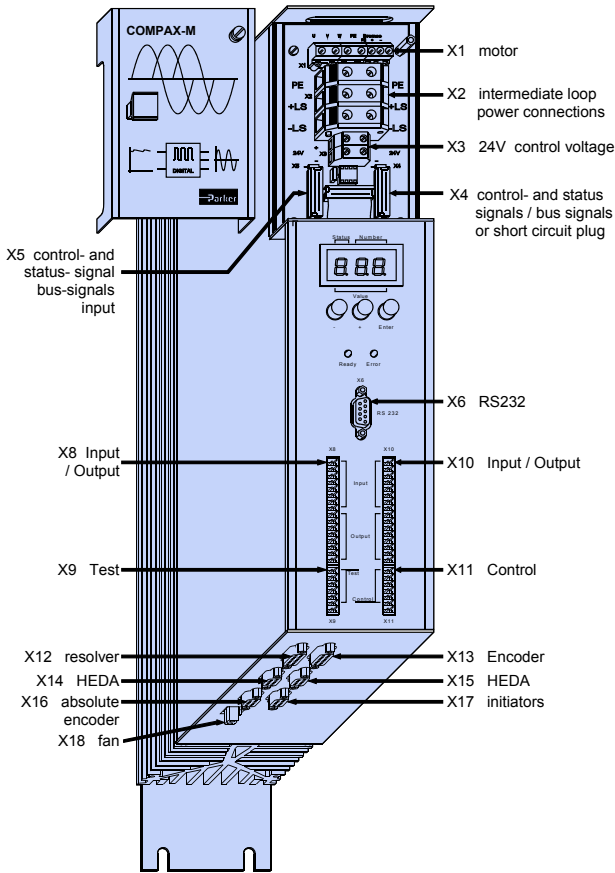

Fan configuration:

Units with fan:	Units without fan:
COMPAX P100M, COMPAX 05XXM, COMPAX 15XXM	COMPAX 02XXM, NMD10, NMD20

Output data for individual units

Device COMPAX ..	Nominal current [Aeff]	Peak current [Aeff] <5s	Power [kVA]
at mains supply: 400V AC			
P1XXM	5.5	8.5	3.8
02XXM	6.5	8.5	4.5
05XXM	11.5	17.0	8.0
15XXM	25.0	50.0	17.0
at mains supply: 460V AC			
P1XXM	4.5	8.5	3.8
02XXM	5.4	8.5	4.5
05XXM	9.6	17.0	8.0
15XXM	21.0	50.0	17.0

Power supply

The power is supplied via a central mains module; NMD10 or NMD20 (refer to page 12).
 With the component EAM5/01, available as an accessory, DC voltage can be supplied:
 Input voltage range: 100V DC – 650V DC.
 When in regeneration mode, the DC bus voltage must be limited to 750V DC.

Installation / dimensions

Direct wall installation

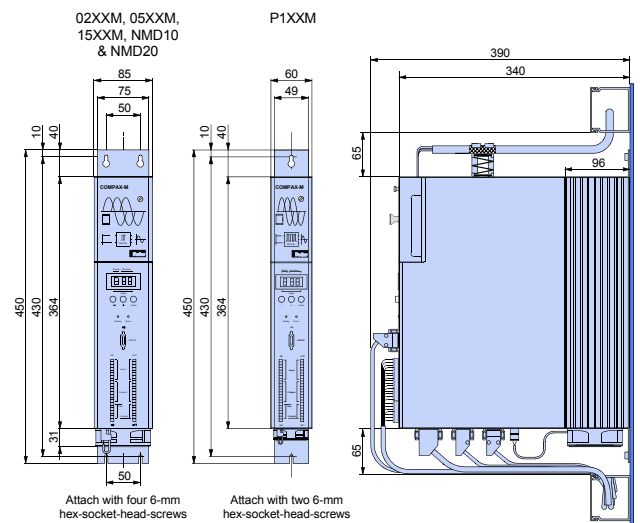

Installation distance: 86mm / 61mm

Indirect wall installation (not for COMPAX P100M)

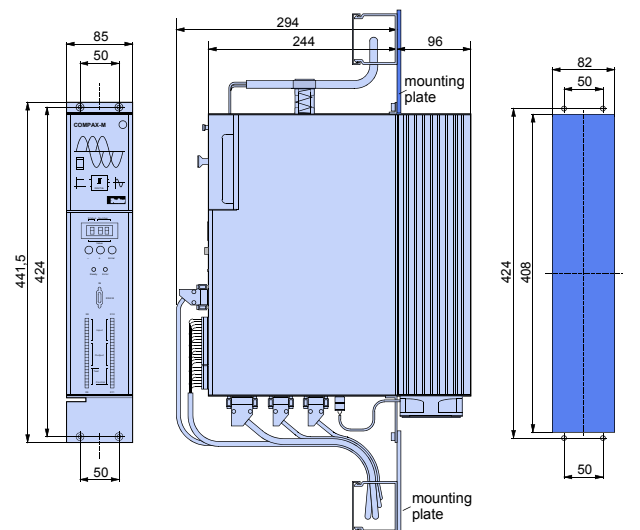

For the angle required, please refer to designation MST2.

NMD mains module

Central mains power module

One mains power module can supply a number of COMPAX-M controllers (up to type 15XXM) with different power ratings. The total load must not exceed the rating of the mains power module. The total load is calculated from the number of axes running simultaneously and their respective power outputs. It should be noted here that not all axes will normally be running simultaneously at rated torque and rated speed.

The following functions are contained within the mains power module:

- AC surge filter
- Ballast resistors
- A separate external supply is required for the 24V DC control voltage.

The power voltage and the auxiliary voltage are supplied from the mains power module. The bus connection for the DC power, for the 24V auxiliary voltage and an internal bus connection for control signals run on the top front model side.

View and assignment of mains modules NMD10 and NMD20

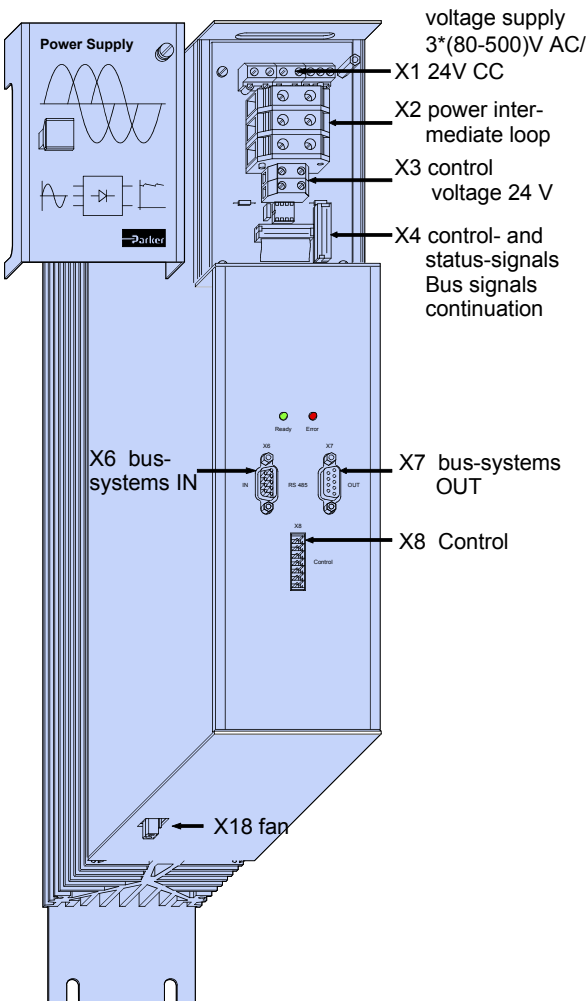

Technical data

- Creates DC power for direct-on-line operation (560V DC from 3 x 400V AC).

CE conformity

- EMC susceptibility/emissions in accordance with EN61800-3.
- Safety: VDE 0160/EN 50178.

Output rating

	Nominal output	Peak output
NMD10:	10 kW	20 kW (<3s)
NMD20:	20 kW	40 kW (<3s)

Mains supply fuse protection

- NMD10/NMD20: 20A/35A K circuit breaker or 16A/35A Neozed conventional fuse.

Mains power

- Nominal 3x400V AC +10% -15% • 45Hz – 65Hz
- Range 80V AC - 500V AC • All mains configurations may be used
- Typical AC mains: 400V ±10%; 460V ±10%; 480V ±5%

Control voltage

- 24V DC ±10% • Fuse protection: 16A • Ripple: <1V_{p-p}

Ready contact: 0.5A; 60V; 30W.

Thermal protection

- 85°C heat sink temperature triggers an emergency stop; the Ready contact drops out.

Overvoltage limitation

- Energy returned to the system during braking is stored in the supply capacitors. The capacity and storable energy is: 1100µF/173Ws
- If the energy returned causes overvoltage, the internal power dump will turn on.

Regenerative power rating	Lasts for	Cooling down time
NMD10		
17 kW	<0.1s	>10s
2.8 kW	<1s	>20s
Without fan: 120W	unlimited	
With fan: 250W	unlimited	
NMD20		
10 kW	<0.1s	>10s
1.7 kW	<1s	>20s
Without fan: 120W	unlimited	
With fan: 200W	unlimited	

➡ External ballast resistors are available for NMD20 (refer to page 16).

COMPAX 35XXM

Connector assignment

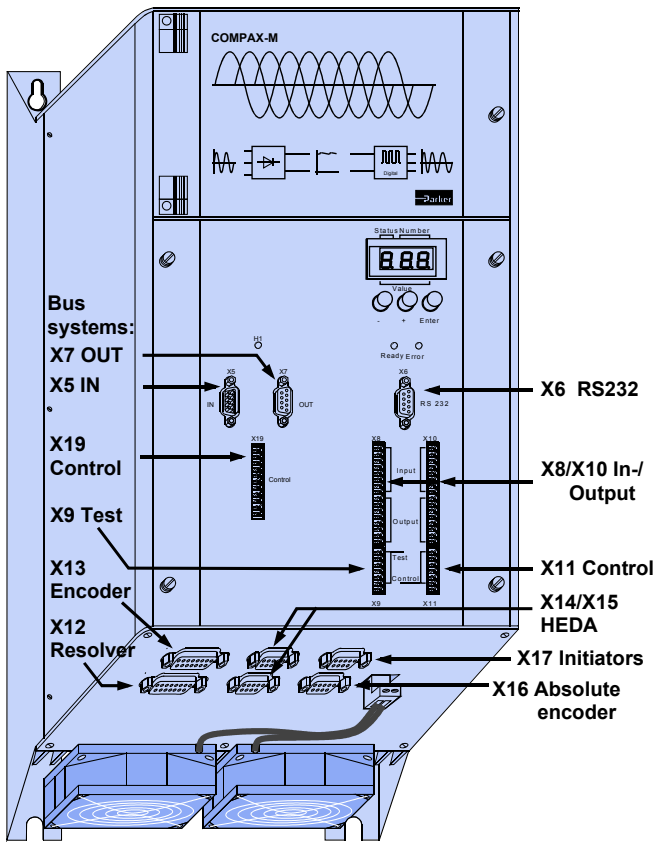

Output data

Unit	Nominal current [Aeff]	Peak current [Aeff] <5s	Power [kVA]
at mains supply: 400V AC			
35XXM	50.0	100.0	35.0
at mains supply: 460V AC			
35XXM	42.0	100.0	35.0

Voltage supply range

- 3 x 250V – 3 x 500V AC; 45 - 65 Hz.
 Typical AC mains: 400V ±10%;
 460V ±10%; 480V ±5%
- Other COMPAX-M controllers can be linked sequentially up to a rating of 15KW.

Mains supply fuse protection

62A K circuit breaker or suitable Neozed conventional fuse.

Regeneration mode

- Storable energy: 3450µF/542 Ws
- External ballast resistance: 10Ω / 2kW
 For external ballast resistors, refer to page 16.

Installation / dimensions

Fastening: 4 M6 Allen screws

Plan view

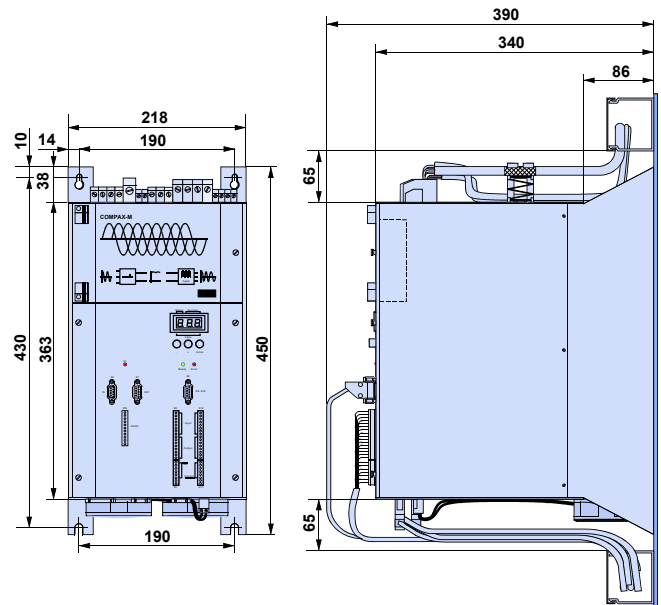
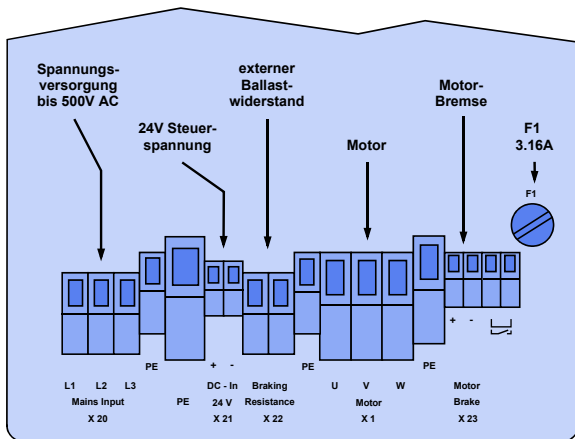

Accessories / options

Software tools

The ServoManager PC program is used to read, edit, print and file parameters and motion programs.

The following functions are included:

- convenient axis manager.
- COMPAX configuration
- downloading of COMPAX parameters
- error tracking and error history
- control of variables
- direct terminal access to COMPAX

Operating panels

(not for COMPAX 1000SL)

The operating panel is available for front plate installation or with the housing; it is used for controlling COMPAX via the digital inputs.

Hand-held terminal

The BDF2/01 hand-held terminal is a convenient menu-guided unit which can be used to operate and configure COMPAX. The hand-held unit is connected to COMPAX via the RS232 interface. It is therefore very well suited to rapid diagnosis and for supporting start-up. The hand-held terminal offers the following functions:

- displays any status value
- menu-guided configuration
- viewing and editing of parameters
- viewing and editing programs
- direct entry of commands

BDF2 hand-held terminal:

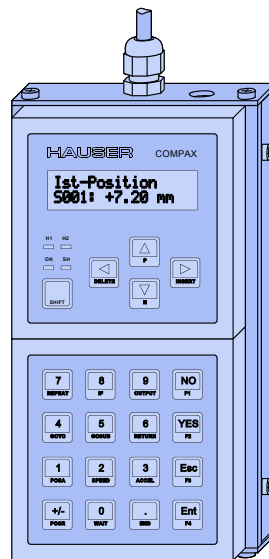

HEDA interface

(Option A1/A4)

COMPAX-to-COMPAX interface

➡ For COMPAX XX00, COMPAX XX60 and COMPAX XX70.

HEDA synchronises several axes for simultaneous processing to a precision of ± 2.5 microseconds. To do this, a COMPAX master (operating mode 1) transmits 2 synchronisation words to the slave axes (maximum 16) to enable synchronisation to occur. The slave axes (operating mode 2) are synchronised automatically. The master only transmits to one axis address.

Application examples:

- Connection of several axes to one encoder and distribution of signals via HEDA.
- Transferring the nominal position value or the actual position value from the master to the slave axes connected via HEDA.
- Coupling several cam profile generators using a common time base
- Applications with constantly-changing master

Interface between IPM and COMPAX XX00.

To implement tracking and contouring tasks with the HAUSER interpolation module (IPM) for PCs and industrial PCs.

Communication occurs via the **HEDA** interface, a rapid synchronous serial interface between the IPM and the COMPAX network.

Functional scope of the IPM and COMPAX network:

- Contours can be stored for up to 9 axes with up to 100 000 points
- 16 (8 with the COMPAX 1000SL) datum-related digital outputs.
- Exchange of data between 9 axes within 1ms (set-point values, auxiliary functions, position, lag error, speed, torque)
- Freedom to program all inputs and outputs
- Internal native-language memory can still be used to its full extent
- Can be independently operated as a single axis positioning system

Parker servomotors

The following features are common to all motors:

- ◆ Sinusoidal EMC
- ◆ Standard flange
- ◆ IP 65 type of protection (IP 64 wave)
- ◆ Integrated resolver/SinCos®
- ◆ Class F insulation
- ◆ Peak torque up to three times nominal torque for maximum of 3 seconds

For more information, please request our motors catalogue (no. 192-060011).

EMC measures

AC surge filter

The following input filters may be used for RF suppression and/or for compliance with the emission limit values as specified by EN61800-3.

**NMD10 / COMPAX
45XXS / 85XXS
COMPAX 1000SL:**
(COMPAX 1000SL motor
cable > 50m)

Type: NFI01/02

NMD20: Type: NFI01/03

Dimension diagram:

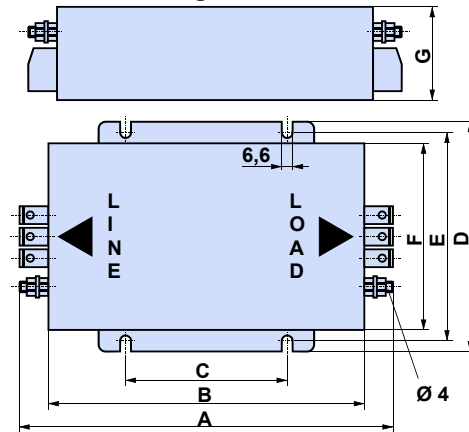

	NFI01/02	NFI01/03
A	177	240
B	151	217
C	70±0.3	115±0.3
D	140	159
E	125	145±0.5
F	111	129
G	65	64

COMPAX 35XXM: Type: NFI01/04

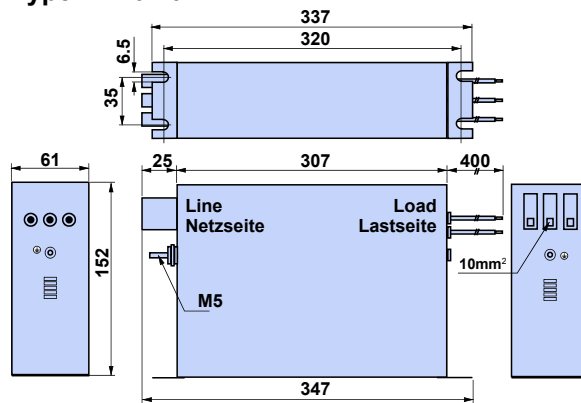

COMPAX 35XXM with sequentially mounted COMPAX-M controllers: Type: NFI01/05

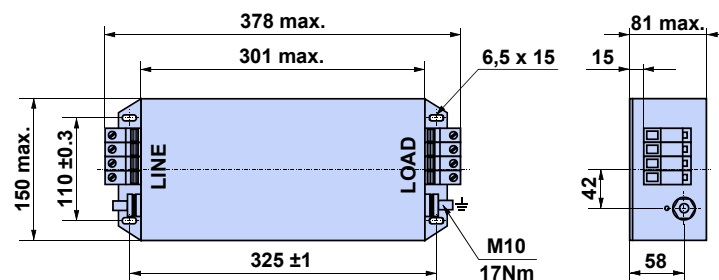

AC surge filter / motor output filter

COMPAX 1000SL,
COMPAX 25XXS:

COMPAX 25XXS: motor cable >10m
COMPAX 10XXSL: motor cable <50m
NF101/01 Dimension diagram:

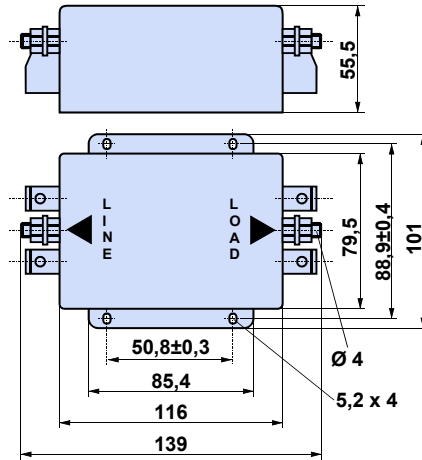

COMPAX 25XXS: motor cable ≤10m

NF101/06 Dimension diagram:

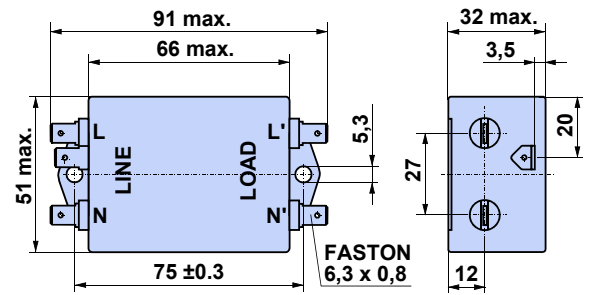

Length of connection between input filter and unit:

- Unshielded: <0.5m
- Shielded: <5m

Motor output filter

We supply motor output filters for use with long motor leads (greater than 20m)

Up to 16A nominal motor current:

- Type: MDR01/01 16A / 2mH

Up to 30A nominal motor current:

- Type: MDR01/02 30A / 1.1mH

Over 30A nominal motor current:

- Type: MDR01/03 >30A / 0.64mH

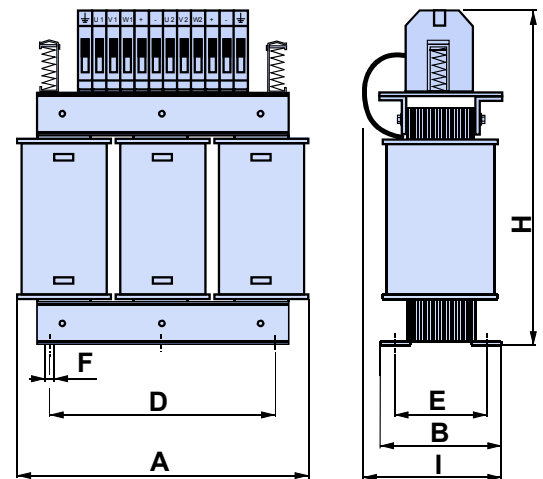

	MDR01/01	MDR01/02	MDR01/03
A [mm]	150	180	205
B [mm]	67	76	107
D [mm]	113	136	157
E [mm]	50	57	83
F [mm]	6	6	7
H [mm]	195	195	260
I [mm]	95	110	150
Weight [kg]	4	6	17

External ballast resistors

NMD20 with external ballast resistance of 15Ω

Regenerative power rating	Lasts for	Cooling down time
BRM4/01: 0.57 kW	unlimited	
6.8 kW	<1s	>20s
37 kW	<0.4s	>120s
BRM4/02: 0.74 kW	unlimited	
8.9 kW	1s	>20s
37 kW	<0.4s	>120s
BRM4/03: 1.50 kW	unlimited	
18 kW	<1s	>20s
37 kW	<0.4s	>20s

COMPAX 25XXS with external ballast resistance of 56Ω

Regenerative power rating	Lasts for	Cooling down time
BRM5/01: 180W	unlimited	
1 kW	<1s	>10s
2.3 kW	<0.4s	≥8s

COMPAX 45XXS/85XXS with external ballast resistance of 22Ω

Regenerative power rating	Lasts for	Cooling down time
BRM6/01: 450W	unlimited	
6.9 kW	<1s	>20s
28 kW	<0.4s	≥120s

COMPAX 35XXM with external ballast resistance of 10Ω

Regenerative power rating	Lasts for	Cooling down time
BRM7/01: 2.00 kW	unlimited	
56 kW	<1s	>100s
17 kW	<1s	>10s

COMPAX 10XXSL with external ballast resistance of 100Ω

Regenerative power rating	Lasts for	Cooling down time
BRM8/01: 60W	unlimited	
253W	<1s	≥10s

Dimension diagram:
BRM4, BRM6 and
BRM7

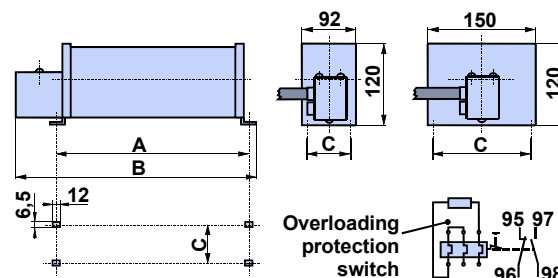

➔ The ballast resistors are provided with a 1.5m connection lead. The maximum permitted length is 2m.

Dimension diagram:
BRM5/01

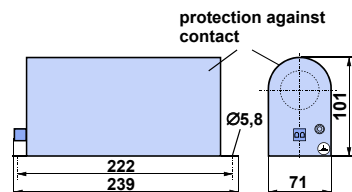

0.3m connection lead
(max. 2m permitted)

Dimension diagram:
BRM8/01

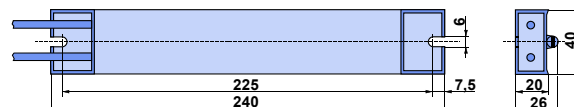

0.25m connection lead.
(max. 2m permitted)

COMPAX software variants

In addition to the basic unit (COMPAX XX00) for general positioning tasks, software variants are also available for special applications:

Solutions are available for a wide range of applications by configuring a basic unit using add-on modules. This modular approach allows you to add or change hardware and software options to implement a solution tailored exactly to your requirements. Each solution is therefore only based on standard hardware. The basic unit for all variants is the COMPAX XX00M and this is used for general positioning tasks. The application-specific unit variants can be distinguished from the basic unit by a numerical code which follows the COMPAX name. The first two digits indicate the power of the output stage, the next two digits describe the application-specific variants.

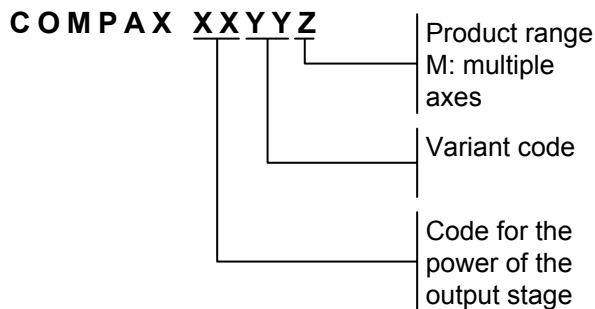

COMPAX 1570M therefore represents an output stage with 15kW power (15..) and the "electronic cam control" variant (..70). COMPAX XX30 represents the "round table control" variant (..30) with an unspecified output stage (XX..).

Our qualified staff are always available to assist when selecting the appropriate variants.

COMPAX XX30: indexing table control

COMPAX XX30 can be used to position and control round tables, switching tables and other rotary systems with high levels of precision.

The positions are programmed in degrees. The direction of rotation may be positive or negative.

In addition to the standard COMPAX command set, special commands are used for the pitch calculator. A pitch command can be used to subdivide the table into equal angle segments.

The position is measured via the resolver installed on the motor end or a high-resolution sensor. Support is provided for external position monitoring to increase the positional accuracy.

- External position monitoring possible
- Pitch calculator with up to 1000 steps per revolution
- Manual fine table setting

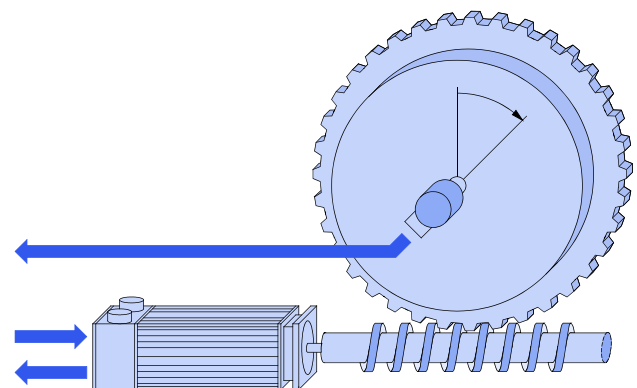

- E12: output stage enable
- E13: measuring error corrected by external position measurement
- E14: release brake
- A14: no measuring error
- A16: no power to final stage

COMPAX XX50: cutting on the fly

Function not available with the COMPAX 1000SL! Implement this function with the electronic cam control.

Continuously driven saws and shears, continuous processing

A saw carriage is attached parallel to the direction of material flow. This is accelerated to the speed of the material to be processed and then travels at the same speed as the material. If the relative speed between material and saw carriage is zero, synchronous running has been achieved. COMPAX will report this state via a digital output. Now the cutting process is performed by running the cutting tool across the direction of travel at right angles. Synchronous running is ended via a digital input and the carriage stops. The carriage then moves automatically (or in a defined manner) to its initial position or to a predetermined position. The saw then waits until the material feed has travelled the distance corresponding to the cut length.

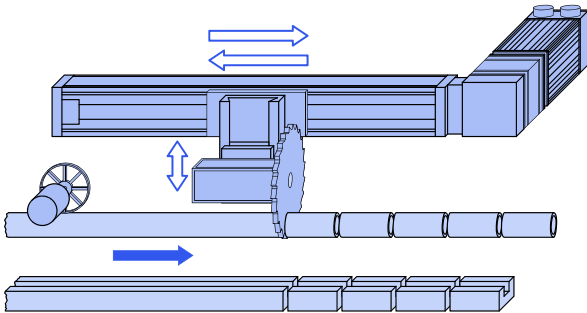

Angled beam saw

A derivative of the continuously driven saw is the angled beam saw, used for wide materials. Here, the saw guide (the linear axis) lies at a fixed angle above the material to be cut. The saw blade is at right angles to the direction of material travel. If the saw is moved, this results in a saw movement in the direction of material travel. This movement depends on the angle between the saw guide and material. The control system uses the beam angle to calculate the saw's feed speed so that synchronicity is set between the saw blade and material. The relative speed therefore becomes zero. Once the cutting process is complete, the saw is raised and returned to its waiting position.

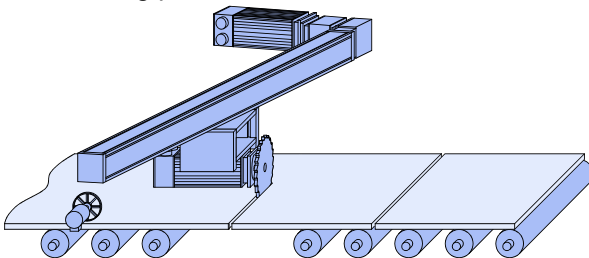

Mark-related machining (registration)

In some applications, the material feed is not continuously measured but a measurement is taken whenever a mark made on the material is reached. The longitudinal measurement then only begins once the mark has been detected and this has been communicated via a COMPAX input.

Reject length, chaff length

With increasing material speed, longer machining times and decreasing cut lengths, the drive spends increasingly less time in the waiting position. If this waiting time approaches zero, then the control unit switches to a substitute length, commonly known as the reject length. COMPAX reports this state via an output. If compliance cannot be maintained with the reject length, which is normally greater than the standard dimension, the control unit switches into chaff mode. This is the minimum length which can be cut.

Manual cutting

When cutting manually, synchronisation is started directly from the waiting position. In such instances, the specified length is not taken into account.

Head cut - initial machining

Special provision is made for handling the first synchronisation request after a START signal is received.

Material simulation

During the start-up phase, when there is usually no material available, the material speed can be simulated using a parameter or a potentiometer on the override input.

Further examples of machining processes while in motion:

- stamping • filling • screwing • pouring • drilling

Special inputs and outputs:

- E13: manual cutting
- E14: mark signal valid
- E15: end of synchronous travel
- E16: mark input
- A14: synchronous comparator
- A15: reject length too small
- A16: reject length

COMPAX XX60: electronic gear units

Range of application:

Synchronous angle control, synchronous speed control, processing while in motion.

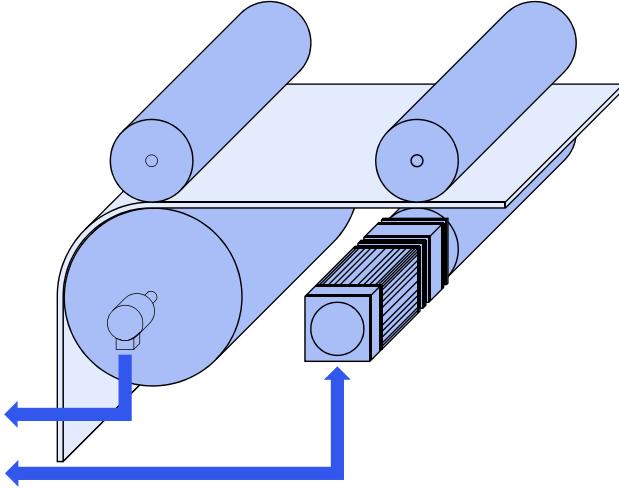

Depending on the operating mode, COMPAX XX60 can read and process an external master signal either as an alternative to or in conjunction with the internal master. The external master signal can be generated by:

- ◆ an encoder on a master axis or
- ◆ an encoder emulation from COMPAX and/or SV drive, if these are controlling the master drive.

It is recorded via an interface in COMPAX. The encoder pulse assessment is set using parameters. This makes it possible to run a slave drive unit synchronously to the master unit. A ratio of 1:1, or a ratio in a large setting range ($i > 1$ or $i < 1$) can be selected via parameters. A negative prefix can be used to signify reversed direction of rotation. COMPAX XX60 has two parameters for determining standard ratio factors.

The external master input can be controlled by two real time inputs (delay time 1ms). In addition to the enable input, which approves the external master signal for the controller, there is the option of switching between the two standard ratio factors.

Example:

Internal reference as dimensional reference

When the dimension reference is an internal reference, the internal nominal value specifications are applied to the datum point of the slave drive. External command pulses are added to the current position as relative positioning. External nominal value specifications do not move the datum point.

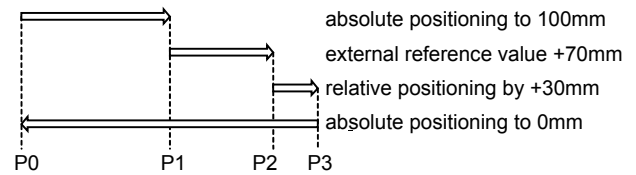

- ◆ Absolute positioning to 100 mm (P1).
- ◆ Approval of external nominal value (E16="1"). Unit travels up to +70 mm in response to impulses from a command sensor (P2).
- ◆ Relative positioning by +30mm (P3)
- ◆ Absolute command to datum point (P0)

Master position as dimensional reference

If the dimensional reference is a master position, the internal datum point of the slave drive is shifted by the externally specified nominal value. The internal reference system is altered (can be corrected again by a reference journey).

Superimposed movements are possible in this operating mode. You can carry out positioning relative to the master position. This can be used to undertake an internal machining program on a moved work-piece.

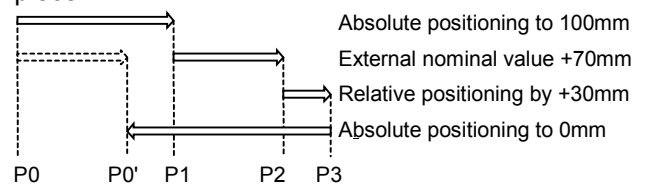

Clarification of this operating mode is provided in the figure. This figure is based on the positioning cycle shown previously. Initially, the following axis is referenced to the internal datum point (P0). When the external nominal value is read, the datum point is shifted by the value specified.

When using the absolute command for the datum point (POSA 0), the system is positioned to P0'. P0' is shifted by the value of the external positioning relative to P0.

The external nominal value can also be activated during an internal running move and the internal positioning superimposed.

Special inputs and outputs:

- E14: switching the dimensions reference to internal reference or master position.
- E15: external switching of transmission factor.
- E16: engaging external nominal value.

COMPAX XX70: electronic cam control

- Mechanical cam and camshaft function implemented electronically in a safe and reliable manner -

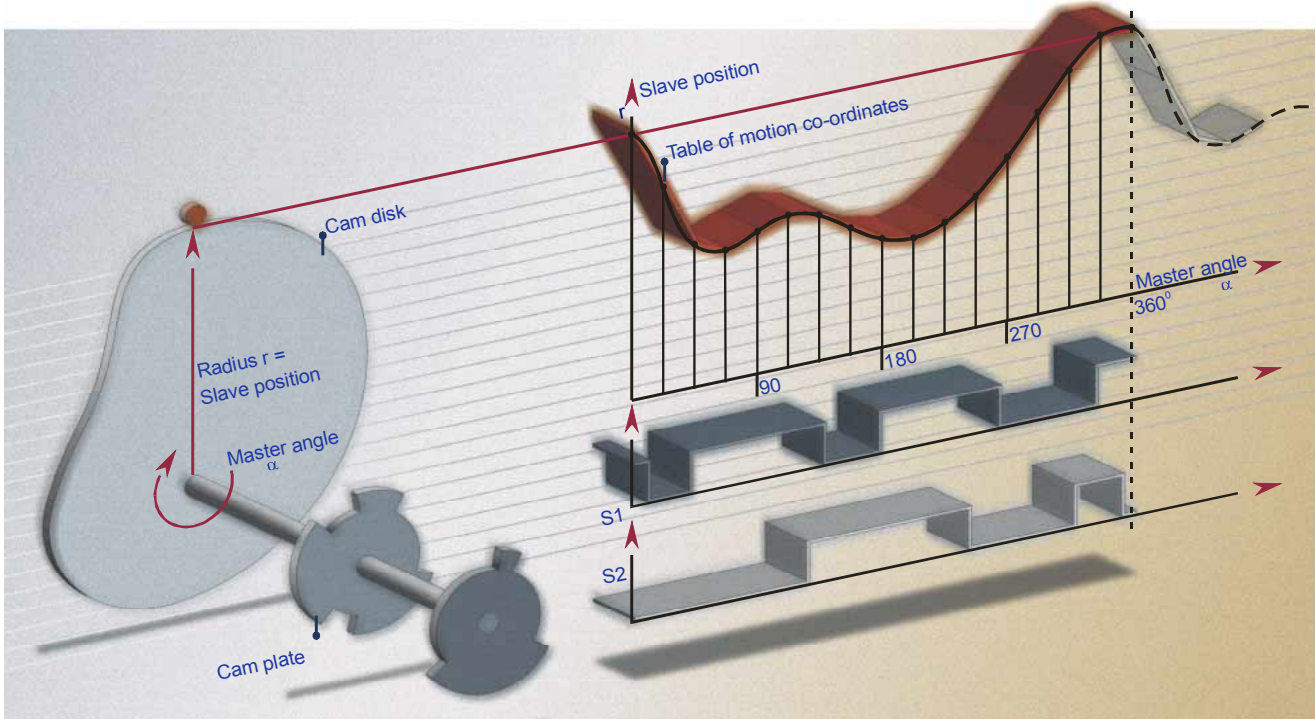

The field of application

- Using the COMPAX XX70 compact servo controller, mechanical cams and camshafts can be implemented electronically.
- The movement of the main axis is recorded by an incremental encoder. COMPAX XX70 generates the setpoint of the slave axis according to the movement relationship requested and controls the drive accordingly. The slave axis is implemented using a 3-phase servo motor (either synchronous or asynchronous).

Typical fields of application can be found in the packaging industry.

Within a power range of 2.5kW - 35kW, the COMPAX XX70 allows the drive power to be decentralised, thereby reducing:

- space requirements
- variety of parts required
- mechanical coupling components

This results in:

- smaller machines
- reduction in cost
- shorter set-up times
- less expenditure on maintenance

The implementation

• The cam profile ...

...is stored in COMPAX XX70 as a sequence of reference points in non-volatile memory and has the following properties:

- Up to 2500 reference points between which COMPAX interpolates in a linear fashion
- Repeatability: up to 0.02 degrees
- Several profiles can be stored at the same time
- Profiles can be selected externally
- Dynamic switching between profiles using the "Interlink curves" function

• The camshaft...

...is simulated using auxiliary functions which can be assigned to all reference points. COMPAX has the following auxiliary functions:

- Programmable control of 8 digital outputs. The initial pattern is set up when processing the first reference point
- An analogue voltage is generated via 2 analogue outputs
A voltage in the range of $\pm 10V$ is output depending on the programmed auxiliary value and on the angle of the master axis.

Cam control functions

The primary task

The control unit's primary task is to move a slave axis in accordance with the profile of motion programmed by the user and depending on the angle of the master axis. Several slave axes with individually programmed profiles can be coupled to the master axis.

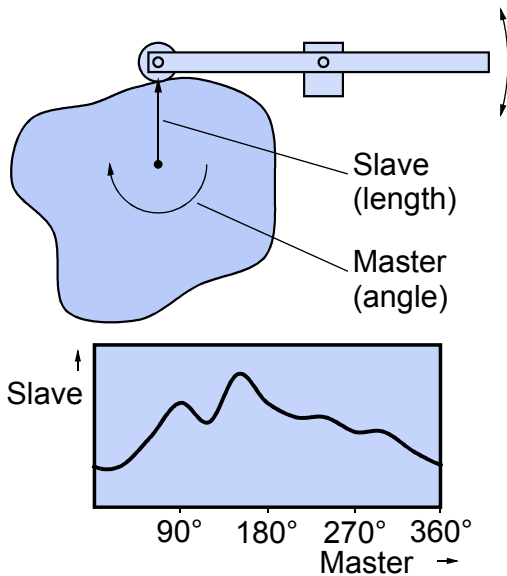

Coupling and decoupling the slave axis

The slave axis can be coupled and decoupled in several ways.

Coupling and decoupling at standstill

The simplest way to initialise the axis is by performing a homing routine after the power has been applied. Once the system has been started externally, COMPAX automatically selects the cam required and is ready to follow the master axis. The master axis usually now starts its running move. The slave axis runs in accordance with the movement relationship entered.

Coupling and decoupling while master axis is rotating

The following options are available for coupling on a rotating master axis:

- When the external "couple" control signal is received, the slave axis starts up, then moves down the stored profile, starting from the programmed synchronous position (M_S). Decoupling occurs in the same manner.

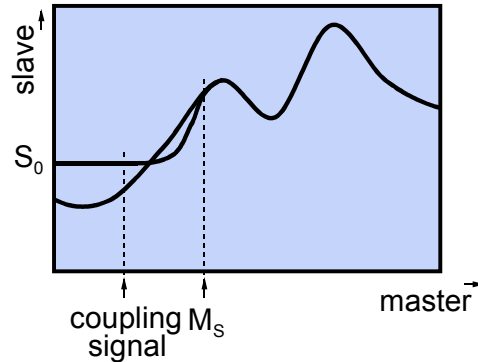

- When the external "couple" signal is received, the slave axis only starts up once the master axis has also reached the programmed coupling position (M_E). The slave axis moves from the specified synchronous position and does so synchronously with the master axis. Decoupling occurs in the same manner, i.e. the slave axis at the decoupling position (M_A) exits synchronous mode and slows down at the braking position (M_B) to come to rest at S_0 .

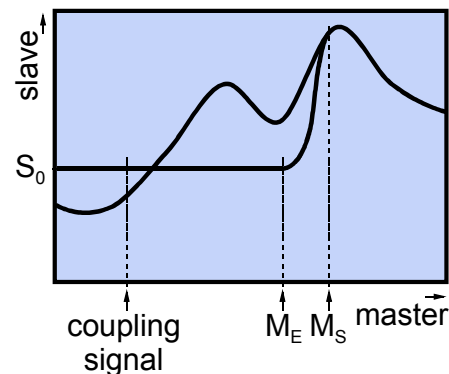

- ➡ The option of dynamic cam changeover also allows for the implementation of individual coupling and decoupling operations.

Programmable cam cycles

You can determine whether the slave axis should continually follow the master axis or whether the coupling to the master axis should be ended after a defined number of cam cycles.

Lag warning

You can monitor the variation between the actual position and the programmed profile by means of a preset "lag warning". COMPAX will generate an output signal whenever this value is exceeded.

Electronic cam control

Label synchronisation

In the packaging and printing industry, synchronisation of a slave axis to printed labels is often necessary in order to compensate for material slip. If the slave position is adjusted by the amount of slip, calculated between product and label sensor, the error can be corrected until the next label appears.

- c) Edge-triggered via a control input for a single master cycle.

Application:

Asynchronous starting of a profile which must be referenced to a product carried on a belt at regular intervals.

Starting synchronisation

When the master is at a standstill

The slave is informed of the master's present position before the start. Recording of the master position is initiated by a control input.

When the master is moving

Targeted start of master position recording:

- a) Statically or dynamically via a control input.
- b) Via a control input in conjunction with the next edge of the encoder index track.

Cam design service

When working with applications for the COMPAX XX70 electronic cam generator, there is always the option of having Hauser create all the necessary profile data.

The Technical Support department will perform this task as a service which is charged according to cost. A program called "Optimus Motus" is used as a software design tool. Depending on the application, this software tool can be used to implement many different types of motion profile. This offers the possibility of optimising the acceleration requirements of the application and therefore selecting the most economic motor/controller combination.

Example: Cam design using the "Optimus Motus" program

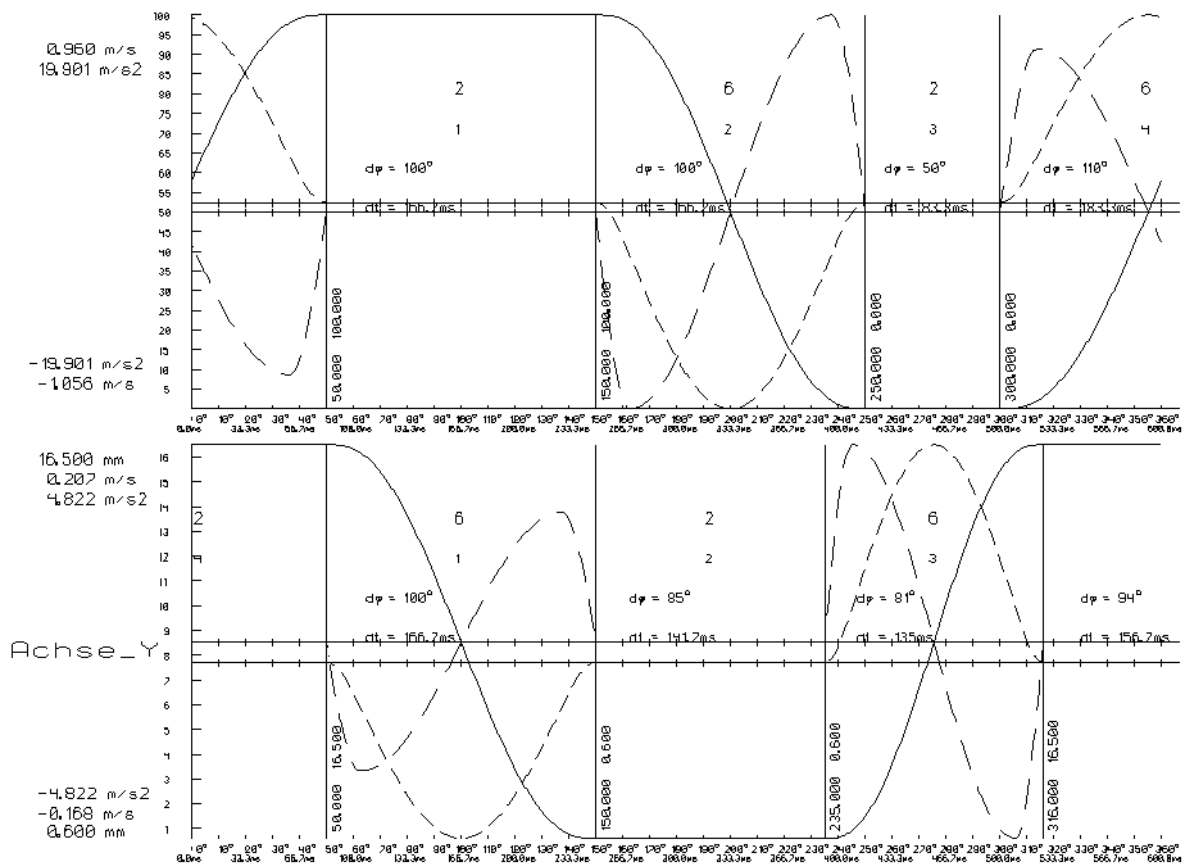

Electronic cam control

CamEditor for creating curves

All the 2500 available data records in the reference point memory may be assigned to a single profile or to a number of profiles. Each reference point can generate an auxiliary function signal using the 8 digital and 2 analogue outputs.

Creating profiles

You can use the HAUSER CamEditor to create cam profiles. This is a Windows program and provides the advantages of a Windows interface.

Profile input and creating the reference point table

You specify the fixed points which are essential to the profile. The CamEditor takes these and uses an interpolation process to create intermediate points which reflect the required profile. The result is displayed in graphic form as a position, speed and acceleration plot.

CamEditor may be used to assign auxiliary functions to any reference point.

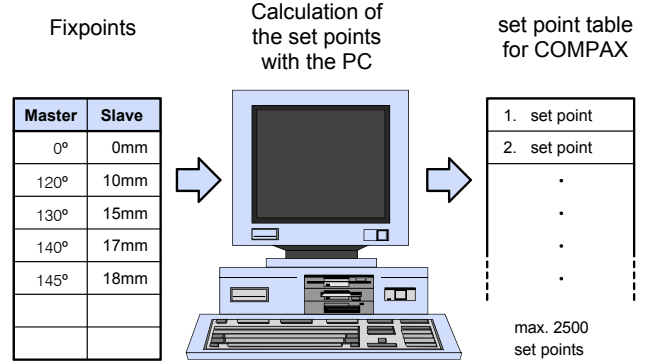

Menu for fixed point entry

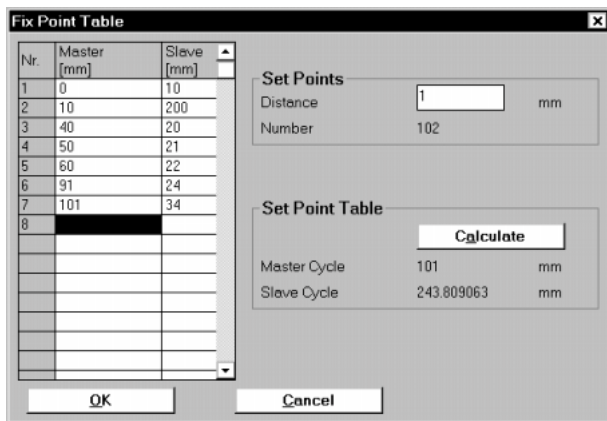

Linear cam diagram

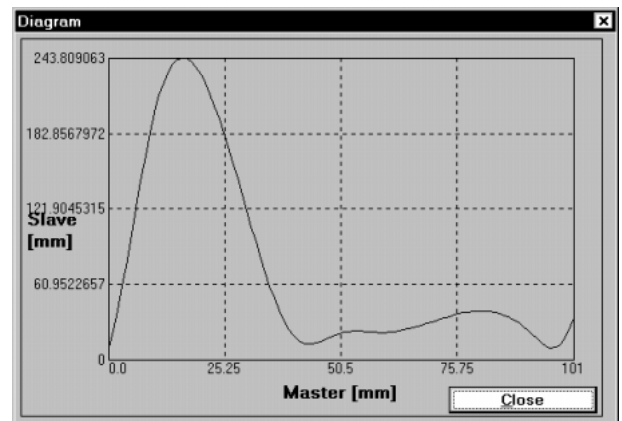

Menu for auxiliary function entry

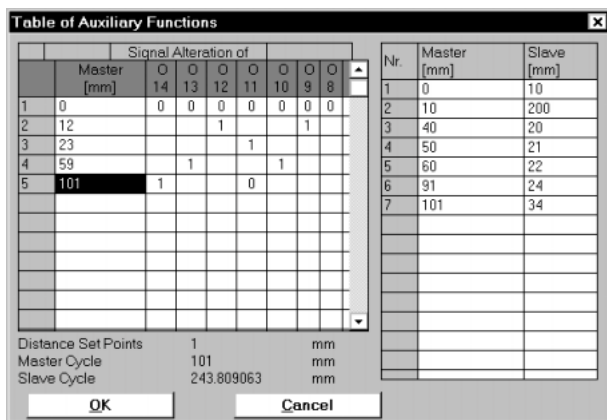

Polar cam diagram

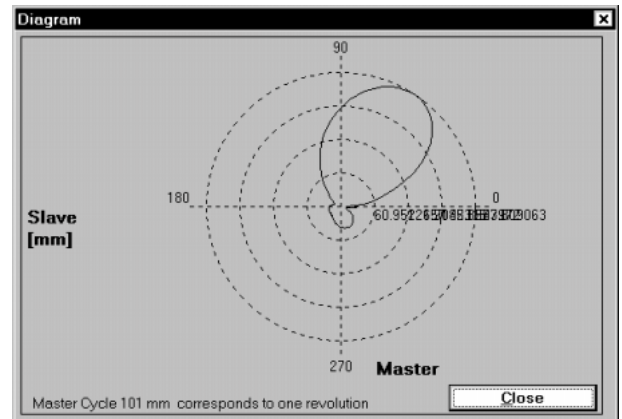

Technical data

Power features

Functional capability

- Position, speed and current controller.
- IGBT output stage protected from short circuits and ground/earth faults.
- Digital positioning controller.
- Motion controller.

Supported motors & resolvers

- Sine-commuted synchronous motors up to a max. speed of 9000 rpm.
- Asynchronous motors.
- Supported resolvers
 - Litton: JSSBH-15-E-5
JSSBH-21-P4
RE-21-1-A05
RE-15-1-B04
 - Tamagawa: 2018N321 E64
 - Siemens: 23401-T2509-C202
- SinCos© support (Stegmann).
- 3 phase synchronous linear motors with:
 - sine-cosine linear encoder (1V_{ss}) or TTL (RS422).
 - digital Hall sensor commutation (5V).

Output data for individual units

Device COMPAX ..	Nominal current [A _{eff}]	Peak current [A _{eff}] <5s	Power [kVA]
at mains supply: 230V AC			
10XXSL	2.5	5.0	1.0
25XXS	6.3	12.6	2.5
at mains supply: 400V AC			
45XXS	6.5	13.0	4.5
85XXS	12.5	25.0	8.6
P1XXM	5.5	8.5	3.8
02XXM	6.5	8.5	4.5
05XXM	11.5	17.0	8.0
15XXM	25.0	50.0	17.0
35XXM	50.0	100.0	35.0
at mains supply: 460V AC			
45XXS	5.4	13.0	4.5
85XXS	10.5	25.0	8.6
P1XXM	4.5	8.5	3.8
02XXM	5.4	8.5	4.5
05XXM	9.6	17.0	8.0
15XXM	21.0	50.0	17.0
35XXM	42.0	100.0	35.0

CE conformity

- EMC susceptibility/emissions in accordance with EN61800-3.
- Safety: VDE 0160/EN 50178.

Voltage supply (limit values)

COMPAX-M (NMD)

- 3*80V AC - 3*500V AC; 45-65Hz.

COMPAX 35XXM

- 3 x 250V – 3 x 500V AC; 45 - 65 Hz.

COMPAX 25XXS

- 3*80V AC - 3*250V AC; 45 - 65 Hz
1*100V AC-1*250V AC; 45-65Hz

COMPAX 10XXSL

- 1*100V AC-1*250V AC; 45-65Hz

COMPAX 45XXS/85XXS

- 3*80V AC - 3*500V AC; 45-65Hz.

Mains supply fuse protection

K circuit breaker or suitable Neozed conventional fuse.

- NMD (COMPAX-M)
NMD10: 16A (K circuit breaker: 20A)
NMD20: 35A
- COMPAX 35XXM: 62A
- COMPAX 25XXS: 1x230V AC: 16A
3*230V AC: 10A
- COMPAX 10XXSL: 16A
- COMPAX 45XXS/85XXS: 16A

DC bus voltage

- 300V DC with 3(1)x230V AC.
- 560V DC of 3x400V AC supply.
- 650V DC with 3x460V AC.

Output voltage to motor

Ignoring power losses, motor output rating is 86% of the AC supply voltage available

Braking operation

- Storable energy
 - NMD10/20: 1100µF / 173Ws
 - COMPAX 25XXS: 1000µF/27 Ws
 - COMPAX 45XXS: 330µF/52 Ws
 - COMPAX 85XXS: 500µF/80 Ws
 - COMPAX 1000SL: 660µF/17 Ws
- Ballast resistors (refer to page 16)

Technical data

Control voltage

- ◆ 24V DC $\pm 10\%$, Ripple $< 1V_{SS}$
Current required:
 - 1.3A for COMPAX 35XXM.
 - 1A for COMPAX 45XXS/85XXS.
 - 0.8A for the other units.
 - digital outputs, each 100 mA max.
 - if needed, for fan approx. 100 mA.
 - for motor holding brake (0.35A-1.6A).
 - if needed, absolute encoder: 0.3A.

Accuracy

Positioning of the motor shaft:

- With Resolver:
Resolution: 16 bits (= 0.3 minutes of angle)
Absolute precision: ± 15 minutes of angle
- With SinCos[®]:
Resolution: 21 bits (= 0.3 seconds of angle)
Absolute precision: ± 90 seconds of angle

Maximum power dissipation

- COMPAX 10XXSL:50W
- COMPAX P1XXM: 140W
- COMPAX 02XXM / NMD10/20:..120W
- COMPAX 05/10/15XXM:.....250W
- COMPAX 25XXS:80W
- COMPAX 45XXS/85XXS: 170W
- COMPAX 35XXM:.....610W

Native-language memory

250 data records, protected from power failure.

Data record functions

- Positioning commands, I/O instructions, program commands:
ACCEL, SPEED, POSA, POSR, WAIT, GOTO, GOSUB, IF, OUTPUT, REPEAT, RETURN, END, WAIT START, GOTO EXT, GOSUB EXT, SPEED SYNC, OUTPUT A0, GOTO, POSR SPEED, POSR OUTPUT , +, -, *, /.

Target value generator

- Ramps: linear, quadr., smooth; 10ms...60s.
- Travel specified in increments, mm, inch or variable using a scaling factor.

Monitoring functions

- Mains power/auxiliary control voltage.
- Motor and power stage temperature/locked-shaft protection.
- Lag error monitoring.
- Ready contact: 0.5A; 60V; 30W.

Ambient conditions

- Temperature range: 0...45°C.
- Max. relative air humidity in acc. with DIN 40040 class F ($\leq 75\%$) non-condensing.

Interfaces

Control inputs: 16 (8 for COMPAX 1000SL)

- 24V DC, 10 kOhm.

Control outputs: 16 (8 for COMPAX 1000SL)

- active HIGH, short circuit protected; 24V/100 mA.

RS 232

- 9600 Baud or 4800 Baud
(for COMPAX 1000SL, fixed at 9600 Baud).
- Length of words 8 bits, 1 start bit, 1 stop bit.
- Software handshake XON, XOFF.

Programmable controller data interface (not for COMPAX 1000SL)

- Via 5 binary inputs and outputs.

Encoder interface (option; standard for COMPAX 1000SL)

- Encoder emulation: 512 or 1024 counts/rev
- Encoder input: RS422 interface; supply: 5V; 120-5000 lines/rev

COMPAX 1000SL signal interfaces (optional)

- Encoder emulation or
- Encoder input or
- Step/direction input or
- Analogue input $\pm 10V$

Absolute value sensor interface (option A1) (not for COMPAX 1000SL)

- Supply voltage: 24V $\pm 10\%$.
- Sensing code: grey code, single step.
- Direction of counting: in clockwise direction when looking at the shaft: rising.
- Data interface: RS422 /24-bit data format (start: MSB). • Cycle frequency: 100 kHz.

SinCos[®] (option S1/S2/S3)

- High-resolution encoder instead of resolver.
- Singleturn or Multiturn (absolute value over 4096 motor revolutions).
- Option S2 with multiturn: absolute value sensor with programmable transmission factor.
- Option S3 for linear motors.

HEDA: synchron, serial real time interface

Included in option A4 or option A1.

Bus connection options

All with opto-isolated bus link.

RS485

- Max. 115k Baud • 2 or 4 wire/RS485

Interbus S

- 2-conductor remote bus • 500 kBaud.
- max. 64 participants per ring.

Profibus

- 1.5M Baud • Sinec L2-DP and FMS.

CS31

- COMPAX - ABB interface.

CANbus

- Up to 1.0MBaud • Basic CAN.
- CAN protocol in acc. with specification 1.2.
- Hardware in acc. with ISO/DIS 11898

CANopen

- Protocol in acc. with CiA DS 301.
- Profile CiA DS 402 for drives.

Operation

Parameter input/status request

- Via COMPAX hand-held terminal.
- Via RS232 and bus interface.
- Via the programmable controller data interface (not for COMPAX 1000SL).
- Status query also via the 3-digit LED display on the front plate (not for COMPAX 1000SL).

Housing

Housing

- Fully-enclosed metal housing.
- Insulation: VDE 0160/protection class IP20.
- IP54 on request.

Connections

- Motor, power bus, control inputs & outputs via terminals.
- Sensor cables & interfaces via two-part connectors.

Installation

- Panel-mounting, suitable for installation in industrial control cabinets.

Dimensions

- NMD/COMPAX-M: refer to page 11.
- COMPAX 25XXS: refer to page 9.
- COMPAX 10XXSL: refer to page 8.
- COMPAX 45XXS/85XXS: refer to page 10.
- Weights: COMPAX P1XXM:..... 5.6 kg
COMPAX 10XXS: 1.6 kg
COMPAX 25XXSL: 4.6 kg
COMPAX 45XXS/85XXS: . 6.5 kg
COMPAX 02XX:..... 7.1 kg
COMPAX 05/15:..... 7.8 kg
COMPAX 35XXM:..... 22.5 kg
NMD10:..... 7.6 kg
NMD20:..... 8.1 kg

Standard scope of supply

- COMPAX with User Guide.
- X8, X9, X10, X11 mating connectors.
- ServoManager.

Mains power module

For technical data, please refer to page 12.

Permissible 3-phase mains power supplies

The units (COMPAX or NMD) can be operated on all mains configurations¹. Examples:

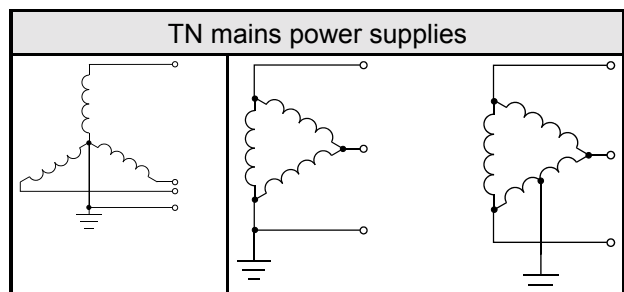
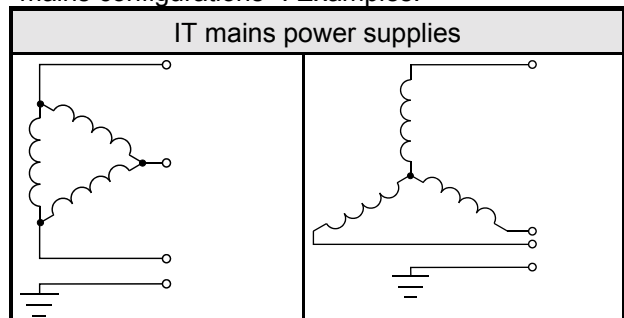

¹When using Delta mains power supplies, note that CE requirements (low voltage guideline) are no longer satisfied when the voltage between a phase and earth >300V AC (isolated measurement voltage).

COMPAX order code

COMPAX order code				A	/	D	/	E	/	E	/	F	/	S
COMPAX-M performance class														
3.8 kVA	P	1												
4.5 kVA	0	2												
8.0 kVA	0	5												
17.0 kVA	1	5												
35.0 kVA	3	5												
COMPAX-S(L) performance class														
1.0 kVA	1	0												
2.5 kVA	2	5												
4.5 kVA	4	5												
8.6 kVA	8	5												
Variants														
Standard		0	0											
Round table control		3	0											
Synchronous cycle control (not for COMPAX 1000SL)		5	0											
Electronic gearbox		6	0											
Electronic cam control		7	0											
Unit type														
COMPAX-M														M
COMPAX-S (L)														S
Options														
No absolute value sensor / real time bus option requested														0
HEDA real time bus (incl. absolute value sensor module) (not for COMPAX 1000SL)														1
HEDA real time bus for COMPAX 1000SL														4
D/A monitor option not requested														0
D/A monitor (not for COMPAX 1000SL)														1
Encoder input option not requested (not for COMPAX 1000SL)														0
Encoder input (with line terminator) (not for COMPAX 1000SL)														2
Encoder input (without line terminator) (not for COMPAX 1000SL)														4
Analogue speed specification (not for COMPAX 1000SL)														7
Encoder emulation option not requested														0
Encoder emulation (not for COMPAX 1000SL)														3
Field bus option not requested														0
RS 485 interface (4-wire)														1
Interbus S interface														2
Profibus														3
CAN bus														4
RS 485 interface (2-wire)														5
CS31 protocol (ABB)														7
CANopen														8
Sine-cosine option not requested														0
Feedback module for high-resolution sensor														1
Feedback module for high-resolution sensor – multiturn with programmable transmission factor														2
Feedback module for linear motors														3

Order code for accessories

Order code														
10kW mains power module (only in conjunction with COMPAX-M)	N	M	D	1	0	/	--	--						
20kW mains power module (only in conjunction with COMPAX-M)	N	M	D	2	0	/	--	--						
Monitor box for option D1 (D/A monitor) (not for COMPAX 1000SL)	A	S	S	0	1	/	0	1						
Operating panel (without housing for front plate installation) (not for COMPAX 1000SL)	B	D	F	0	1	/	0	2						
Operating panel (with housing) (not for COMPAX 1000SL)	B	D	F	0	1	/	0	3						
Interface cable between operating panel and COMPAX (not for COMPAX 1000SL)	S	S	K	0	6	/ ¹						
User terminal with 1.5m cable	B	D	F	0	2	/	0	1						
Ballast resistor for NMD20 (0.57 / 37kW)	B	R	M	0	4	/	0	1						
Ballast resistance for NMD20 (0.74 / 37kW)	B	R	M	0	4	/	0	2						
Ballast resistance for NMD20 (1.5 / 37kW)	B	R	M	0	4	/	0	3						
Ballast resistance for COMPAX 25XXS (0.18 / 2.3kW)	B	R	M	0	5	/	0	1						
Ballast resistance for COMPAX 45XXS / 85XXS (0.57 / 28kW)	B	R	M	0	6	/	0	1						
Ballast resistance for COMPAX 35XXM (2.0 / 56kW)	B	R	M	0	7	/	0	1						
Ballast resistance for COMPAX 10XXSL (60 / 253W)	B	R	M	0	8	/	0	1						
AC surge filter for COMPAX 25XXS (motor cable >10m) OR COMPAX 1000SL (< 50m motor cable)	N	F	I	0	1	/	0	1						
AC surge filter for COMPAX 25XXS (< 10m motor cable)	N	F	I	0	1	/	0	6						
AC surge filter for NMD10 / COMPAX 45/85XXS / COMPAX 1000SL (COMPAX 1000SL > 50m motor cable)	N	F	I	0	1	/	0	2						
AC surge filter for NMD20	N	F	I	0	1	/	0	3						
AC surge filter for COMPAX 35XXM	N	F	I	0	1	/	0	4						
AC surge filter for COMPAX 35XXM with sequentially mounted COMPAX-M	N	F	I	0	1	/	0	5						
Motor output filter for up to 16A nominal motor current	M	D	R	0	1	/	0	1						
Motor output filter for up to 30A nominal motor current	M	D	R	0	1	/	0	2						
Motor output filter for over 30A nominal motor current	M	D	R	0	1	/	0	3						
Installation set for indirect wall installation (refer to page 11)	M	T	S	0	2	/	0	1						
Module for direct DC supply from COMPAX-M	E	A	M	0	5	/	0	1						
Sensor cable between encoder and COMPAX	G	B	K	1	1	/ ¹						
Sensor cable between absolute value sensor and COMPAX	G	B	K	0	1	/ ¹						
Interface cable for PC – COMPAX (RS232)	S	S	K	0	1	/ ¹						
Interface cable between encoder emulation - COMPAX; encoder distributor - encoder distributor	S	S	K	0	7	/ ¹						
Interface cable between COMPAX and encoder distributor	S	S	K	0	4	/ ¹						
Interface cable for HEDA: COMPAX (slave) - COMPAX (slave)	S	S	K	1	4	/ ¹						
Interface cable for HEDA: COMPAX (master) - COMPAX (slave)	S	S	K	1	5	/ ¹						
Field bus interface cable: NMD – NMD – COMPAX-S – COMPAX 35XXM	S	S	K	1	3	/ ¹						
Terminal module for the I/Os from COMPAX 1000SL (connection lead: 1m; 2.5m; 5m)	E	A	M	0	3	/ ¹						
Encoder distributor	E	A	M	0	4	/	0	1						
DC power supply for COMPAX-M	E	A	M	0	5	/	0	1						
Bus conclusion: encoder - bus	B	U	S	0	1	/	0	1						
Bus conclusion: HEDA real time bus	B	U	S	0	2	/	0	1						
Bus conclusion: Profibus	B	U	S	0	3	/	0	1						
Interface converter for RS232 – RS485 for F1 option	S	S	U	0	1	/	0	1						

¹ Length codes for shielded cables

Length [m]	1.0	2.5	5.0	7.5	10.0	12.5	15.0	20.0	25.0	30.0	35.0	40.0	45.0	50.0
Code	01	02	03	04	05	06	07	08	09	10	11	12	13	14

Example of SSK01/09: length 25m



Descriptions of the motor connection cables (motor cable, resolver cable) can be found in the "Synchronous servomotors catalogue 192-060011".

Fortunately not all raw eggs ...



**... but good to know that it wouldn't cause a
problem even if they were ..**



Parker Hannifin GmbH & Co.KG
Electromechanical Automation
Robert-Bosch-Str. 22
D-77656 Offenburg, Germany
Tel.: +49 (0)781 509-0
Fax: +49 (0)781 509-98176
Website: www.parker-eme.com
e-mail: sales.hauser@parker.com

Parker Hannifin plc
Electromechanical Automation
Arena Business Centre, Holy Rood Close
Poole, Dorset BH17 7BA UK
Tel.: +44 (0)1202 60 6300
Fax: +44 (0)1202 60 6301
Website: www.parker-eme.com
e-mail: sales.digiplan@parker.com