

QUAD/10

QUADRATURE ENCODER INTERFACE MODULE

DELTA

COMPUTER SYSTEMS, INC.

Independent module translates rotary motion encoder signals to linear motion transducer signals

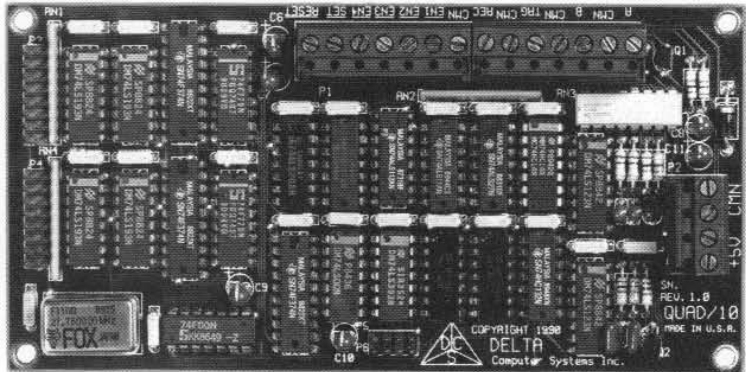

The QUAD/10 module electronically converts quadrature encoder phase signals to equivalent Temposonics® linear transducer signals. Specific applications of the module vary widely, however the QUAD/10 module is particularly useful when an application using a multi axis controller (ie, DELTA's VMC 186/40, MC 186/40 and TMC 188/40 modules) needs to work with a rotary encoder.

As with DELTA's multi axis controllers, a large number of industrial controllers are designed to work with Temposonics style linear transducers. If the application calls for a small number of axis or rotary motion control, the QUAD/10 can be used to reduce the number of different types of controllers in the system. In other words, the QUAD/10 permits the controller designed for linear motion control to be used for rotary motion control.

Note: The QUAD/10 is intended to be used for position control not speed control.

Key Features:

- Single axis rotary to linear position translator for Temposonics transducer compatible controllers
- Cost effective solution for rotary motion control in a linear motion environment
- State logic for encoder phases guarantee glitch free conversion
- Independent Qualifying Position Controls:

- Preset position
- Enable preset position
- Position direction
- Enable position changes

Encoder Requirements

Quadrature phases A & B with optional index pulse C
 Index pulse recommended to preset position to known location using *SET and *EN4 controls.
 Open collector outputs (NPN) for phase A, B and index pulse C

Maximum encoder speed:

Module Translator Clock	Maximum Pulses/Second
27.75Mhz (TMC 188/40)	86Khz
50.00Mhz (MC 186/40)	156Khz
55.50Mhz (VMC 186/40)	173Khz

Linear Sensor (Temposonics) Interface

	Logic Levels	Pulse
Pulse from controller (Trigger)	High > 4.75v; Low < 0.8v Input Z is 220 ohms	.8 to 1.2us
Pulse to controller (Receive)	High > 4.75v; Low < 0.8v @ max of 50ma	.8 to 1.2us

Maximum position is 65,535 module translator clocks
 Standard module translator clocks are: 27.5Mhz, 50Mhz, or 55.5Mhz

Module Control Inputs

*SET	When low presets position programmed by module jumpers
*EN1	When low enables negative (Up Count) position changes
*EN2	When low enables positive (Down Count) position changes
*EN3	When low enables position changes
*EN4	When low enables *SET control
INPUTA	Phase A of Encoder
INPUTB	Phase B of Encoder

Logic levels (CMOS) High > 4.75v; Low < 0.80v
 Default state (all inputs) High via 2.2k pull-up resistor
 Minimum pulse width 10 microseconds

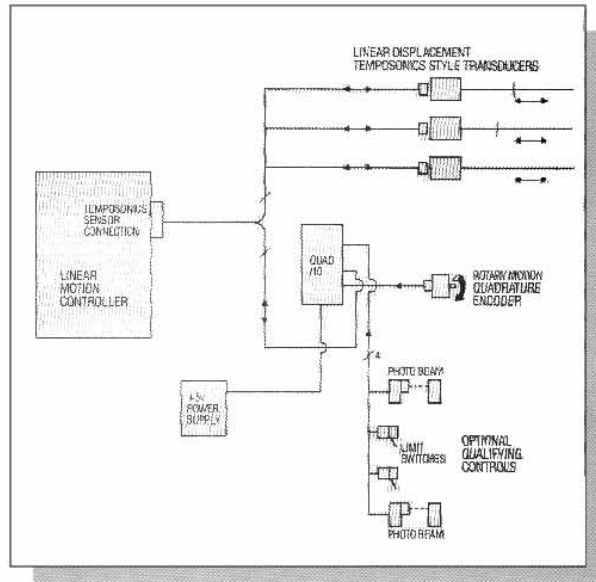

Power Requirements

5.0 volts ± 5% at 250ma

Size

3.0x6.0 inches (mounting pattern 2.70x5.70 with 0.125 holes)
 Compatible with Augat Reed Devices Inc. SNAPTRACK®TK2-6

Ordering Information

QUAD/10-TI	27.5Mhz clock for use with TMC 188/40
QUAD/10-MU	50.0Mhz clock for use with MC 186/40
QUAD/10-VM	55.5Mhz clock for use with VMC 186/40

Please note: QUAD/10 board must use the same translator clock frequency as the mating controller. Special translator clock frequency available on request.

Temposonics is a registered trademark of MTS Systems Corporation. SNAPTRACK is a registered trademark of Augat Reed Devices Inc.



1818 SE 17th Street
 Battle Ground, Washington USA 98604-8579
 (360) 254-8688 FAX: 254-5435

www.comoso.com

Printed in USA 971001