

Series A

Air Cylinder

Series J

Hydraulic Cylinder

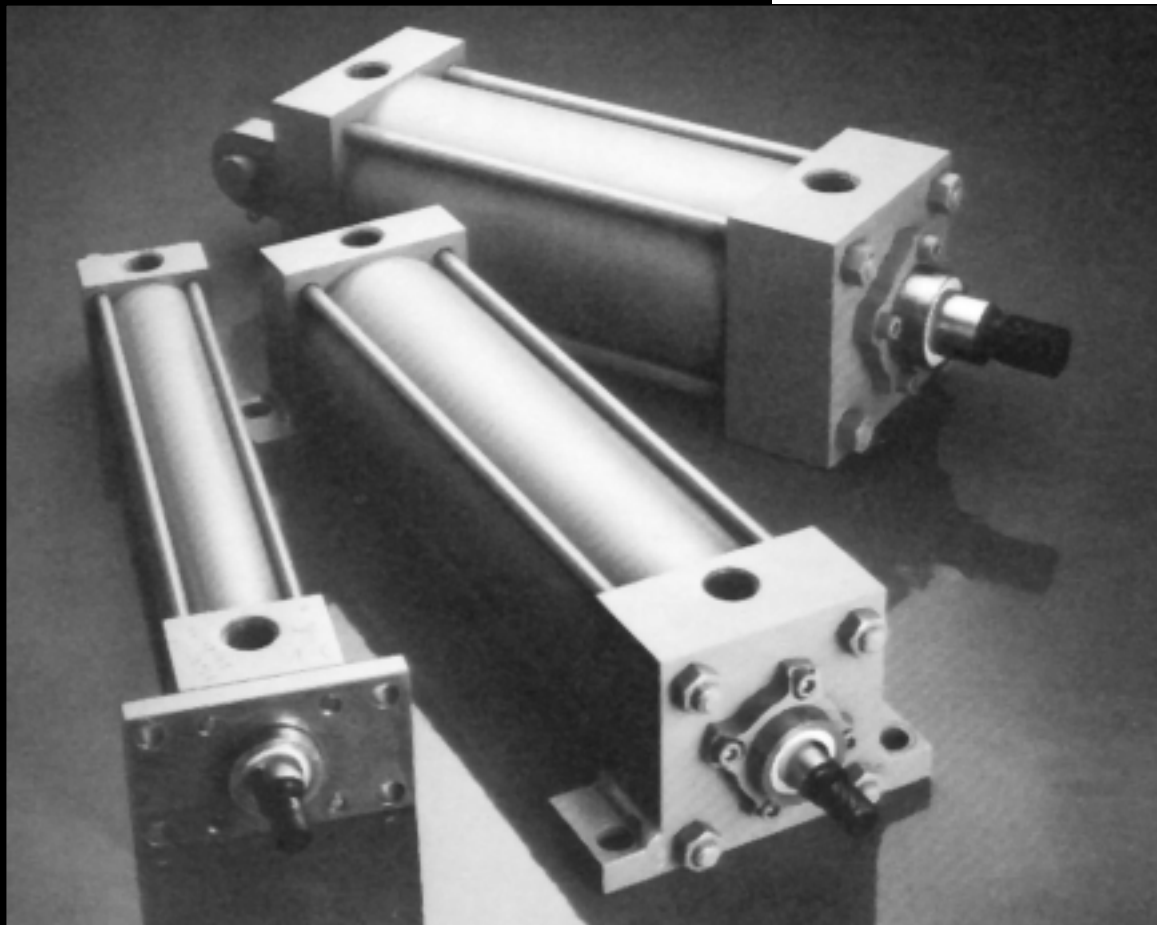

Series A Air Cylinders
Up to 250 PSI Air Pressure
Bore Sizes 1½" through 20"
Pre-Lubricated

Series J Hydraulic Cylinders
Up to 2500 PSI Pressure
Bore Sizes 1½" through 20"



Table of Contents

Miller Cylinder Selection Guide	Page 1
A & J Cylinder Features	2-3
Mounting Styles.....	4-5
1½"- 20" Bore Cylinder Reference Chart & Warranty.....	6-7
Cylinder Mountings (1½"- 7" Bores)	8-39
Model 50 Series, Tie Rods Extended	8-9
Model 61, Rectangular Flange - Head End.....	10-11
Model 62, Rectangular Flange - Cap End.....	12-13
Model 65, Square Flange - Head End	14-15
Model 66, Square Flange - Cap End	16-17
Model 67 & 68, Rectangular Head or Cap	18-19
Model 72, Side Lugs	20-21
Model 73, Centerline Lugs.....	22-23
Model 74, Side Tapped.....	24-25
Model 77, End Lugs	26-27
Model 81, Trunnion - Head End.....	28-29
Model 82, Trunnion - Cap End.....	30-31
Model 89, Intermediate Trunnion	32-33
Model 84, Fixed Clevis.....	34-35
Model 86, Detachable Clevis	36-37
Model 90, Rear Eye	38-39
Double Rod End	40
Large Bore Cylinder Dimensions (8"- 20" Bores)	41-55
Models 50 & D50, No Mounting.....	42-43
Models 63 & 64, Square Head or Cap	44-45
Models 72 & 73, Side Lug or Centerline Lug.....	46-47
Model 74, Side Tapped & Model 77, End Lugs	48-49
Models 81 & 82, Trunnion Head End or Cap End	50-51
Model 89, Intermediate Trunnion	52-53
Models 84, 86 & 90, Clevis or Rear Eye	54-55
Rod End Styles.....	56
Rod End Accessories	57
Cylinder Parts List and Seal Kits.....	58-59
How To Order.....	60

How To Select A Miller Cylinder

Miller cylinders are available based on air or hydraulic operating pressure. The many styles, sizes and optional features available assure that your application needs are precisely met. To select a Miller cylinder, follow these simple steps.

- Determine the cylinder bore size** necessary to achieve required force using the available operating pressure.
- Based on operating pressure**, determine the series cylinder to use — as explained on the right.
- Turn to the appropriate cylinder selection section.** Select the mounting style (Model No.) which fits your installation needs. Determine the bore and rod sizes available for the model you select. Then complete model selection:
 - Choose a rod end style and the desired rod end accessories.
 - Size the cylinder to meet your application requirements.
- Consider the following conditions** which may require further modifications to the cylinder you have selected. Additional information on each subject is given in the Engineering Aids Section VI.

Quick starts or stops	Confirm that determined thrust is sufficient to accelerate or decelerate cylinder and load within prescribed distance. If standard design, optional cushions are to be used to reduce shock during deceleration, check that peak pressures will be within tolerable limits.
Sufficient speed	Verify that standard port size permits sufficient flow to accommodate speed requirements.
Long push stroke	Check whether stop tube is required to prevent excess bearing loads and wear.
High column loading – long push stroke	Determine if standard-size piston rod is strong enough to accommodate intended load.
Long horizontal stroke	Check for requirement of non-sag piston rod to prevent excess bushing and piston wear.
Low or high operating temperatures	For operation above 180°F, spring-loaded Teflon® U-cup piston seals & Viton RS/WP may be needed.
Nitrogen Service	For dry nitrogen, spring-loaded Teflon® seals are recommended. Spring-loaded Buna seals and silicone lube are available.
High side load	

Low Friction (Low Break-Away). Mixed mountings. Heavy chrome tube or piston rod. Stainless steel piston rods. Metallic piston rod scrapers for contaminants that adhere to rod. 'K' retainer — Thrust key for foot mounted cylinders. Cylinder stroke adjuster, two types which allow adjustment of advance point or return point.	Porting: Oversize pipe ports 'O' ring seal ports for foot mounted cylinder SAE straight thread MS 16142 & MS 33649 Special manifold ports Rod end modifications Proximity sensors, position sensing and non-lubricated Spring return cylinder Options/modifications for special environments
--	--

Other Miller Air and Hydraulic Cylinders. Order catalog by File No.

AL Series Cylinders Up to 250 PSI Permanently lubricated



Our aluminum AL Series air cylinders are available in bore sizes from 1 1/2" through 8". Operating pressures up to 200 PSI. Dimensions are NFPA Standard. (File 8564)

IP Series Cylinders Up to 10 bar Permanently lubricated



Miller's ISO metric (6431) aluminum pneumatic cylinder line. Bore sizes from 32mm-200mm. (File 9817)

H Series Cylinders 3000-5000 psi



Miller's heavy-duty cylinder line for the most demanding hydraulic applications. Bore sizes from 1 1/2" to 20". Heavy-duty construction. (File 7622)

MH Series Cylinders Up to 210 BAR



Miller's heavy-duty ISO Metric (6020-2) cylinder line for hydraulic applications. Bore sizes from 25 mm-200 mm. Heavy-duty construction. (File 9787)

Standard Miller Design Features Boost Performance and Minimize Cylinder Problems

Adjustable Cushions

Unique, optional adjustable cushions reduce shock and cushioning time, permitting quick out-of-cushion starts, increasing machine cycle rates.
Series A—Adjustable
Series J—Self Adjusting

Piston Seals

Durable U-cup seals are mechanically locked in place to prevent rolling and blowout. Temperatures to 180°F standard. To 450°F when using optional spring loaded Teflon® U-cup seals.
Series A—Buna-N Cup Seals
Series J—Teflon® Cup Seals

Piston

One-piece piloted piston provides maximum strength and protection against shock loads. Piston threads increase in size for added strength when oversized rods are required.

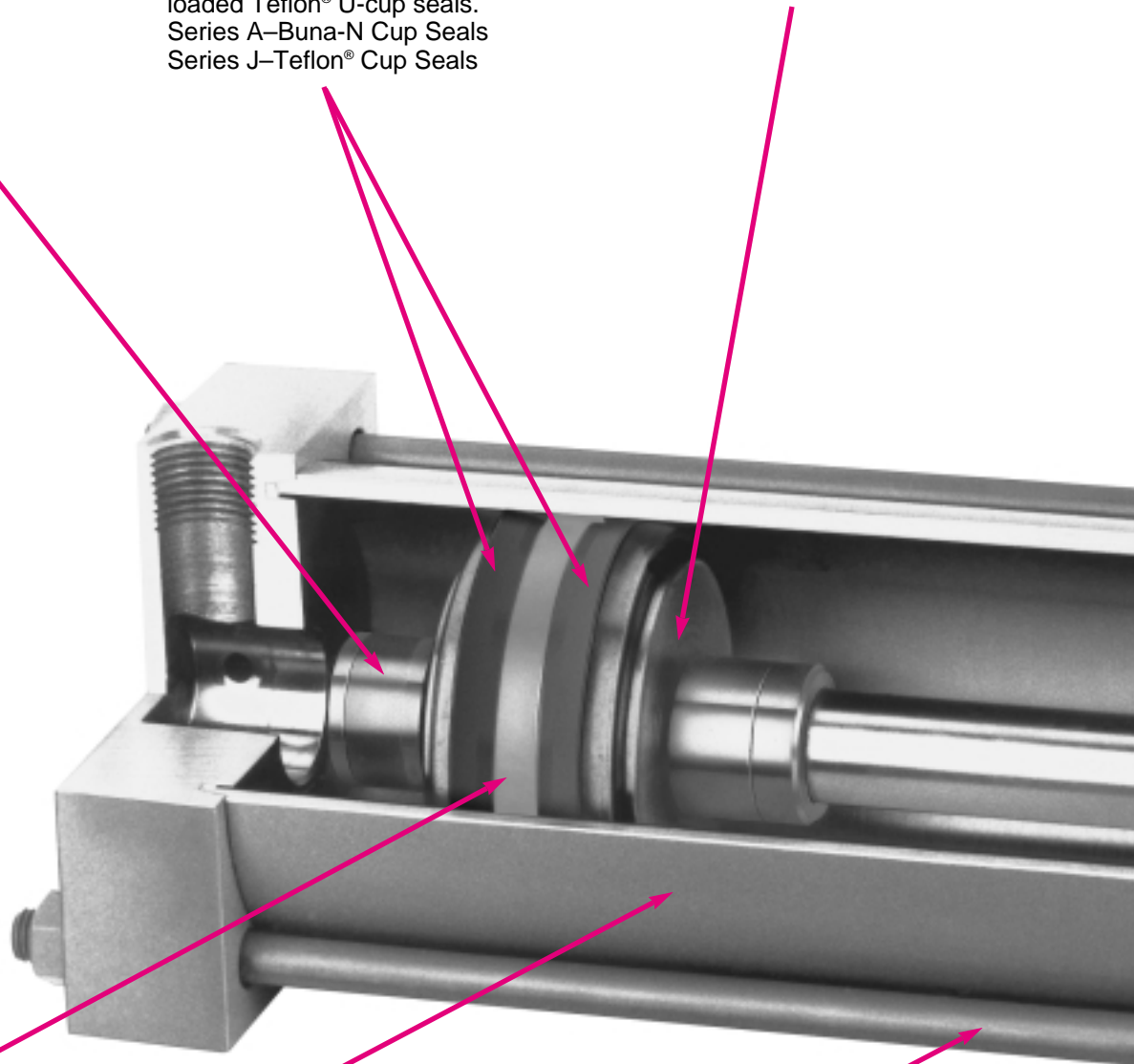

Wear Band

Durable, non-metallic piston wear band prevents metal to metal contact, which can score expensive tubing. Pistons never have to be replaced.

Tube

Series A—Chrome plated I.D. .0003-.0005 thick. Resists wear and corrosion.
Series J—Steel Tube

Tie Rods

High strength, 100,000 to 125,000 PSI minimum yield material. Provide protection against shock pressures.

Tube End Seal

Teflon® "SHEF" tube end seal resists heat, extrusion and shearing. Patented strip-type seal repairs all bore sizes with minimum inventory and downtime.

Bushing

Nodular iron piloted bushing provides 400% longer bearing life than conventional bronze bushings. Protects against side loads. Removes easily using a common Allen wrench. Cylinder tie-rods not disturbed.

Rod Seal

Durable urethane rod seal is pressure-energized and wear-compensating for long, leak-free service.

Wiper Seal

Wipes away dirt that may have accumulated on piston rod and prevents it from entering bushing. Also provides secondary rod seal.

Piston Rod

Case-hardened to 50-55 Rockwell C and chrome-plated rod resists mechanical damage and wear from side loads.

Series A-Pre-Lubricated

A generous quantity of a water resistant lubricant is added during assembly, assuring permanent lubrication.

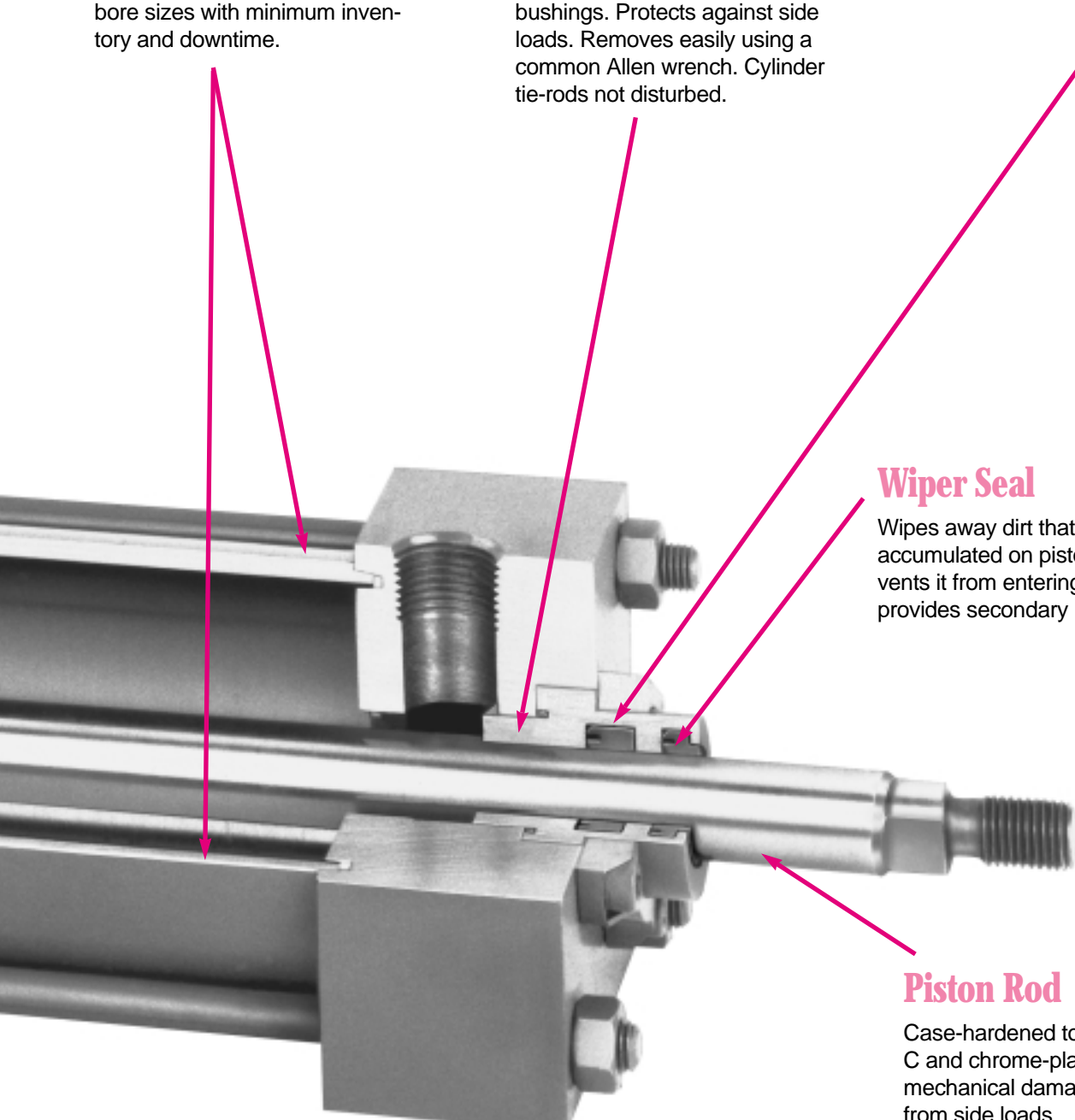

Mounting Styles That Fit Your Installation Requirements

Miller Series A air cylinders operate at internal pressures up to 250 PSI, and Series J hydraulic cylinders operate at internal pressures up to 2500 PSI, depending on bore size. Both series incorporate proven Miller design characteristics to provide safe, reliable power for many heavy-duty industrial applications. Available in 23 standard mounting configurations to provide centerline, foot or pivot installations as explained below.

Centerline Mounting

The preferred cylinder installation method, centerline mounting places the mounting bolts in simple shear or simple tension so that the mounting mechanism is protected from compound forces. Centerline mounting is a rigid mounting style and this requires accurate cylinder alignment to prevent damage to cylinder working parts.

Miller mounting configurations that provide centerline support are tie-rod mounts, flange mounts with rectangular or square flanges fastened to the cylinder head or cap, and centerline lug mounts.

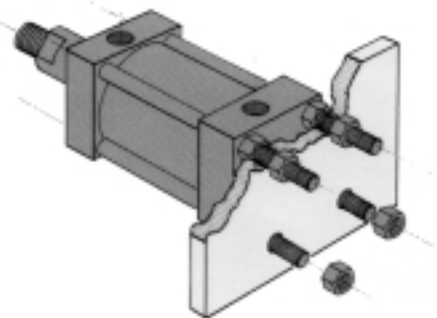

Centerline mounting is preferable since it prevents compound forces from acting on the mounting bolts (tie rod model shown).

Foot Mounting

Foot mounting secures the cylinder along its side. Since the mounting surface plane is thus not centered directly on the line of force, the mounting bolts are subjected to a significant amount of shear stress. The cylinder should be pinned or keyed to absorb the stress of shear loads and allow the mounting bolts to remain in simple tension. Because foot mounts are rigid, they require accurate cylinder alignment.

Lugs, either welded onto the sides or attached to the ends of the cylinder, are the usual form of foot mounts. As an alternative to the use of lugs, flush mounting incorporates tapped mounting holes on the sides of the cylinder head and cap.

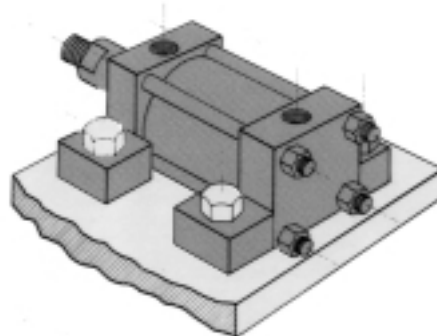

Foot mounting secures the cylinder on its side, but can subject the mounting bolts to compound stress (cylinder side lugs shown).

Pivot Mounting

Pivot mounting is used when the cylinder must pivot during piston motion. Clevis and trunnion mounts are the two methods used to allow this motion.

The clevis end design locates the pivot point at the cap end of the cylinder. Trunnion mounting uses trunnions on the head, cap or side of the cylinder to allow it to pivot at any of three locations. Both clevis and trunnion mounting configurations allow the cylinder to pivot in one plane only.

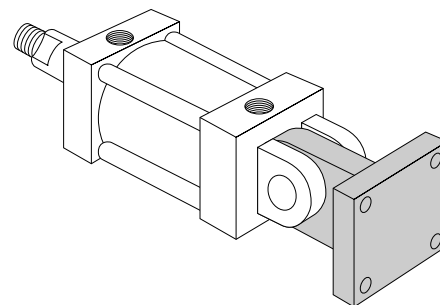

Pivot mounting allows the cylinder to pivot during piston motion (clevis method shown).

An Array of Models In Each Mounting Style

Miller Series A & J cylinders are available in 23 models in your choice of centerline, foot and pivot installation methods. All models are sized to NFPA standards to permit interchangeability with corresponding NFPA-coded cylinders.

Centerline Mounts

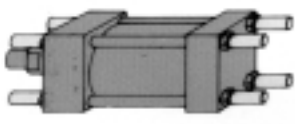

Tie Rod Models 50,
51 (NFPA MX1), 52 (NFPA MX2)
53 (NFPA MX3), 54 (NFPA MX4)

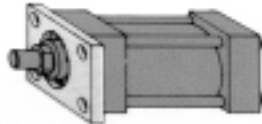

Rectangular Flange/Head End
Model 61 (NFPA MF1)

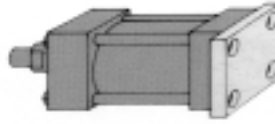

Rectangular Flange/Cap End
Model 62 (NFPA MF2)

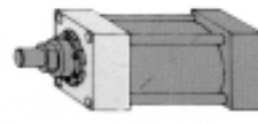

Square Head
Model 63 (NFPA ME3)

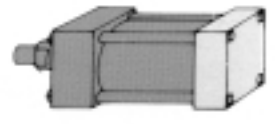

Square Cap
Model 64 (NFPA ME4)

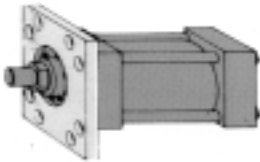

Square Flange/Head End
Model 65 (NFPA MF5)

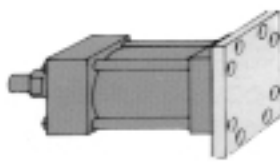

Square Flange/Cap End
Model 66 (NFPA MF6)

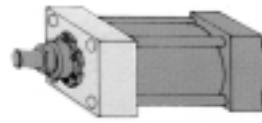

Rectangular Head
Model 67

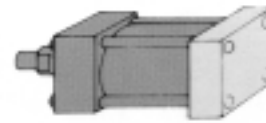

Rectangular Cap
Model 68

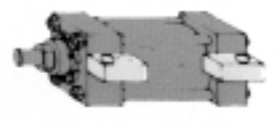

Centerline Lug
Model 73 (NFPA MS3)

Foot Mounts

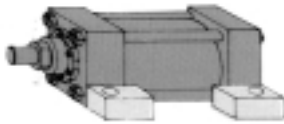

Side Lug
Model 72 (NFPA MS2)

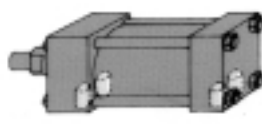

Side Tapped
Model 74 (NFPA MS4)

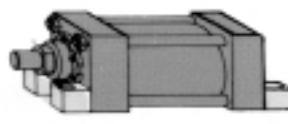

End Lug
Model 77 (NFPA MS7)

Pivot Mounts

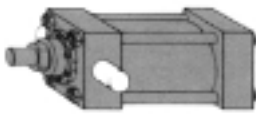

Trunnion/Head End
Model 81 (NFPA MT 1)



Trunnion/CapEnd
Model 82 (NFPA MT 2)



Fixed Clevis
Model 84 (NFPA MP 1)

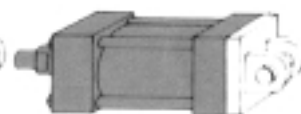

Detachable Clevis
Model 86 (NFPA MP 2)



Intermediate Fixed Trunnion
Model 89 (NFPA MT 4)

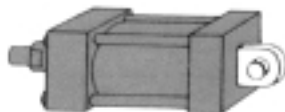

Rear Eye
Model 90 (NFPA MP 3)

Miller Series A Air Cylinders & Series J Hydraulic Cylinders



MAXIMUM OPERATING P.S.I.															
Cylinder Bore Size	1-1/2	2	2-1/2	3-1/4	4	5	6	7	8	10	12	14	16	18	20
Moderate	250	250	250	250	250	250	250	250	250	250	250	250	250	250	250
Severe	250	250	250	250	250	240	240	150	150	150	150	150	150	150	150

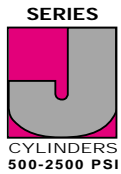

MAXIMUM OPERATING P.S.I.															
Cylinder Bore Size	1-1/2	2	2-1/2	3-1/4	4	5	6	7	8	10	12	14	16	18	20
Moderate	2500	2500	1500	2500	1500	1200	1200	800	800	800	800	800	500	500	500
Severe	1500	1500	1000	1500	1000	800	800	500	500	500	500	500	300	300	300

Series A & J Selection: 1-1/2" - 7" Bore Cylinders

Mounting Configuration (Model No.)	BORE/ROD SIZE AVAILABILITY																
	1-1/2" Bore		2" Bore			2-1/2" Bore			3-1/4" Bore				4" Bore				
	STD. ROD	OVERSIZED RODS	STD. ROD	OVERSIZED RODS	OVERSIZED RODS	STD. ROD	OVERSIZED RODS	OVERSIZED RODS	STD. ROD	OVERSIZED ROD	OVERSIZED RODS	OVERSIZED RODS	STD. ROD	OVERSIZED RODS	OVERSIZED RODS		
	5/8	1***	5/8	1	1-3/8***	5/8	1	1-3/8	1-3/4***	1	1-3/8	1-3/4	2	1	1-3/8, 1-3/4, 2	2-1/2	
50, 52	●	■	●	●	■	●	●	●	■	●	●	●	●	●	●	●	●
51	■	■	●	■	■	●	●	■	■	●	●	●	■	●	●	●	●
53, 54	■	■	●	■	■	●	●	■	■	●	●	●	■	●	●	●	●
61, 65	■	■	●	■	■	●	●++	■	■	●	●	■	■	●	●	●	■
62, 66	●	■	●	●	■	●	●	●	■	●	●	●	●	●	●	●	●
67	●	NA	●	●	NA	●	●	●	NA	●	●	●	●	●	●	●	●
68, 72, 73	●	■	●	●	■	●	●	●	■	●	●	●	●	●	●	●	●
74	●	NA‡	●	NA‡	NA‡	●	●	NA‡	NA‡	●	●	NA‡	NA‡	●	●	●	●
77	●**	■+	●	●**+	■	●	●	■+	■	●	●	●	■	●	●	●	■
81, 82, 84, 86, 89, 90, 94	●	■	●	●	■	●	●	●	■	●	●	●	●	●	●	●	●

Mounting Configuration (Model No.)	BORE/ROD SIZE AVAILABILITY												
	5" Bore			6" Bore			7" Bore						
	STD. ROD	OVERSIZED RODS	OVERSIZED RODS	STD. ROD	OVERSIZED RODS	OVERSIZED RODS	STD. ROD	OVERSIZED RODS	OVERSIZED RODS	OVERSIZED RODS			
	1	1-3/8, 1-3/4	2, 2-1/2	3	3-1/2	1-3/8	1-3/4, 2, 2-1/2	3, 3-1/2	4	1-3/8	1-3/4, 2, 2-1/2	3, 3-1/2, 4, 4-1/2	5
50, 52	●	●	●	●	●	●	●	●	●	●	●	●	●
51	●	●	●	●	●	●	●	●	●	●	●	●	●
53, 54	●	●	●	●	●	●	●	●	●	●	●	●	●
61, 65	●	●	●	■	●	●	●	■	NA	NA	NA	NA	NA
62, 66	●	●	●	●	●	●	●	●	NA	NA	NA	NA	NA
67	●	●	●	●	●	●	●	●	●	●	●	●	●
68, 72, 73	●	●	●	●	●	●	●	●	●	●	●	●	●
74	●	●	●	NA‡	●	●	●	NA‡	●	●	●	●	●‡
77	●	●	■	■	●	●	●	■	●	●	●	●	NA
81, 82, 84, 86, 89, 90, 94	●	●	●	●	●	●	●	●	●	●	●	●	●

- Bolted Bushing
 - Square Retainer
 - ** Mounting lugs at head end must be removed before bushing.
 - *** Cylinders furnished with bi-directional seal and wear band in place of "U" cup seals.
 - + Rod eye for Style 2 rod end interferes with Model 77 mounting lugs.
 - ++ Bolted bushing cap screws extend 3/16" beyond face of mounting plate.
 - ‡ Reduced pressure ratings due to shallow tapped mounting holes.
- Consult Miller Fluid Powers Application Engineering

Miller Series A Air Cylinders & Series J Hydraulic Cylinders

Series A & J Selection: 8" - 20" Bore Cylinders

• = Bolted Bushing

Mounting Configuration (Model No.)	BORE/ROD SIZE AVAILABILITY						
	8" Bore			10" Bore		12" Bore	
	STD. ROD	OVERSIZED RODS		STD. ROD	OVERSIZED RODS	STD. ROD	OVERSIZED RODS
	1-3/8	1-3/4, 2, 2-1/2, 3, 3-1/2, 4, 4-1/2, 5	5-1/2	1-3/4	2, 2-1/2, 3, 3-1/2, 4, 4-1/2, 5, 5-1/2	2	2-1/2, 3, 3-1/2, 4, 4-1/2, 5, 5-1/2
50, 51, 52, 53, 54, 63, 64, 72, 73, 74, 81, 82, 84, 90, 94	•	•	•	•	•	•	•
77	•	•	NA	•	•	•	•
89	•	•	•	•	•	•	NA
86	•	•	•	NA	NA	NA	NA

Mounting Configuration (Model No.)	BORE/ROD SIZE AVAILABILITY					
	14" Bore		16" Bore		18" - 20" Bore	
	STD. ROD	OVERSIZED RODS	STD. ROD	OVERSIZED RODS	STD. ROD	OVERSIZED RODS
	2-1/2	3, 3-1/2, 4, 4-1/2, 5, 5-1/2	2-1/2	3, 3-1/2, 4, 4-1/2, 5, 5-1/2	3	3-1/2, 4, 4-1/2, 5, 5-1/2
50, 51, 52, 53, 54, 63, 64, 72, 73, 74, 81, 82, 84, 90, 94	•	•	•	•	•	•
77	•	•	•	•	•	•
89	•	•	NA	NA	NA	NA
86	NA	NA	NA	NA	NA	NA

Miller Warranty

Subject to the conditions below, Miller Fluid Power Corporation ("Miller") warrants to the first end user (the "Buyer") that Miller's products are free from defects in material and workmanship.

Miller will either repair or replace a defective product, including lowest transportation costs, but not including installation or any other similar charges, provided that (1) the buyer notifies Miller in writing of the claimed defect within 3 years from shipment from Miller's factory, (2) provides a complete explanation of the defect, the application of the product, and such other information concerning use of the product as Miller may request, and (3) returns the product to Miller in accordance with Miller's specific written instructions and authorization obtained from Miller prior to return of the product, and Miller's inspection confirms that the product was defective.

This warranty applies only if the product was used and applied correctly under normal operating conditions and good engineering practice; was installed, operated and maintained in accordance with all instructions issued or published by Miller; was used within stated pressure, media and operating limitations published by Miller and in effect on the date of shipment; and was not subject to abuse, misuse or unauthorized modification.

THIS WARRANTY IS IN LIEU OF ALL OTHER WARRANTIES, EXPRESSED OR IMPLIED, INCLUDING ANY IMPLIED WARRANTY OF MERCHANTABILITY OR FITNESS FOR A PARTICULAR PURPOSE, notwithstanding any disclosure to Miller of the use to which the product is to be put. The Buyer's SOLE AND EXCLUSIVE REMEDY on any claim of any kind for any loss or damage arising out of the manufacturer, sale, delivery or use of Miller's products shall be for the repair or replacement of any defective products as provided herein.

IN NO EVENT SHALL MILLER BE LIABLE FOR ANY SPECIAL, INCIDENTAL OR CONSEQUENTIAL DAMAGES. There are no warranties, express or implied, made by Miller other than the warranty against defects in material and workmanship set forth above, and Miller neither assumes nor authorizes any other person or firm to assume for it any other obligations or liability.

Miller Series A Air Cylinders & Series J Hydraulic Cylinders

Tie Rods Extended
1½" – 7" Bore Cylinders

Model 52-B (NFPA MX2) Bolted Bushing Tie Rods Extended Cap End

Mounting Dimensions (see tables on opposite page)

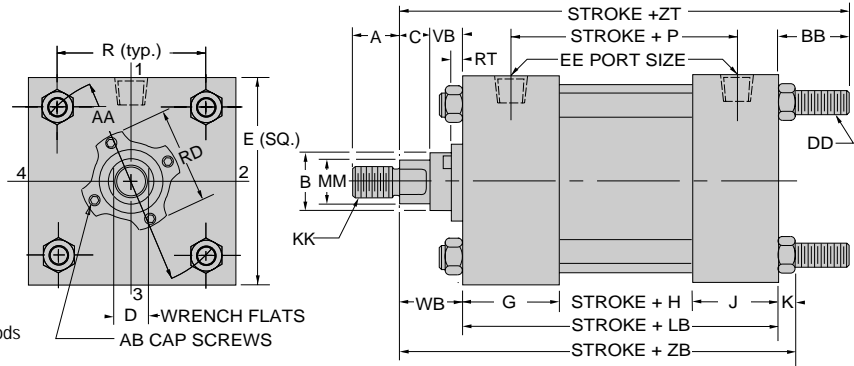
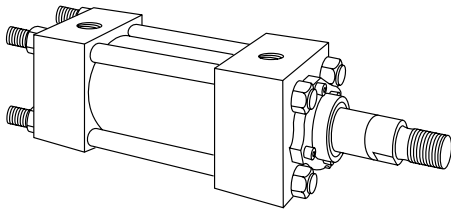

Also Available
Model 50-B No Tie Rods Extended, Model 51-B (NFPA MX1) Tie Rods Extended both ends, Model 53-B (NFPA MX3) Tie Rods Extended head end, Model 54-B (NFPA MX4) two Tie Rods Extended both ends at position #3.
All of the above models can be dimensioned from Model 52-B shown.

Model 52-R (NFPA MX2) Square Retainer Held Bushing Tie Rods Extended Cap End

Mounting Dimensions (see tables on opposite page)

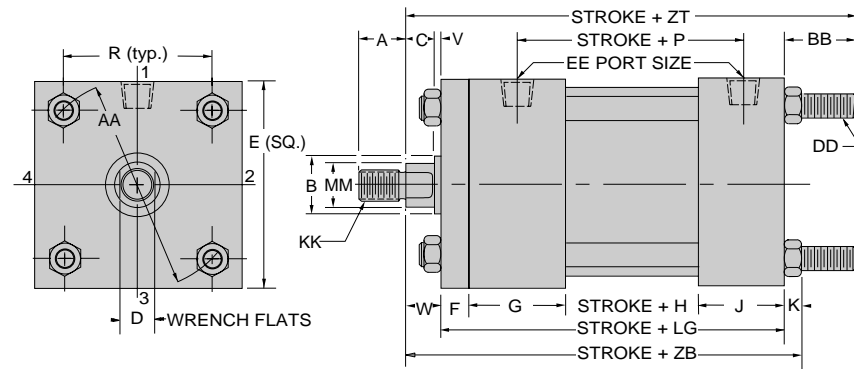
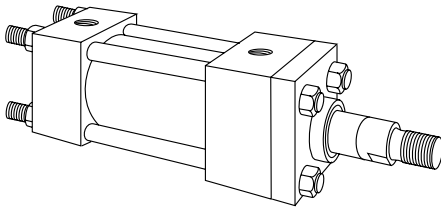

Also Available
Model 50-R No Tie Rods Extended, Model 51-R (NFPA MX1) Tie Rods Extended both ends, Model 53-R (NFPA MX3) Tie Rods Extended head end, Model 54-R (NFPA MX4) two Tie Rods Extended both ends at position #3. All of the above models can be dimensioned from Model 52-R shown.

Common Rod End Styles & Dimensions (See page 56 for complete listing of rod end styles.)

Style No. 2-Standard Threaded on Turndown Section

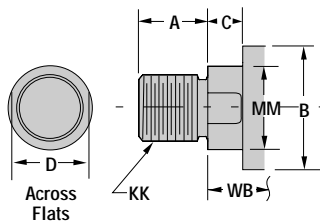

Style No. 4 Short Rod End-Internal Threads

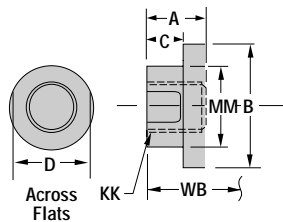

Style No. 6 Studded Rod End

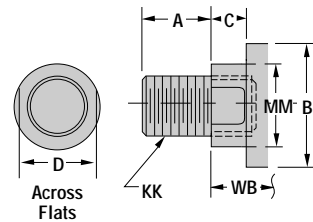

Miller Series A Air Cylinders & Series J Hydraulic Cylinders

Model 50, 51, 52, 53, 54 Bolted Bushing & Retainer Construction

Stroke Plus

Bore Size	AA	E	EE	F	G	J	K	R	BB	DD
1 1/2	2.02	2	3/8-18	3/8	1 1/2	1	1/4	1.43	1	1/4-28
2	2.60	2 1/2	3/8-18	3/8	1 1/2	1	5/16	1.84	1 1/8	5/16-24
2 1/2	3.10	3	3/8-18	3/8	1 1/2	1	5/16	2.19	1 1/8	5/16-24
3 1/4	3.90	3 3/4	1/2-14	5/8	1 3/4	1 1/4	3/8	2.76	1 3/8	3/8-24
4	4.70	4 1/2	1/2-14	5/8	1 3/4	1 1/4	3/8	3.32	1 3/8	3/8-24
5	5.80	5 1/2	1/2-14	5/8	1 3/4	1 1/4	7/16	4.10	1 13/16	1/2-20
6	6.90	6 1/2	3/4-14	3/4	2	1 1/2	7/16	4.88	1 13/16	1/2-20
7	8.10	7 1/2	3/4-14	1	2	1 1/2	9/16	5.73	2 5/16	5/8-18

H	P	LB	LG	LD
1 1/8	2 1/4	3 5/8	4	4 1/8
1 1/8	2 1/4	3 5/8	4	4 1/8
1 1/4	2 3/8	3 3/4	4 1/8	4 1/4
1 1/4	2 5/8	4 1/4	4 7/8	4 3/4
1 1/4	2 5/8	4 1/4	4 7/8	4 3/4
1 1/2	2 7/8	4 1/2	5 1/8	5
1 1/2	3 1/8	5	5 3/4	5 1/2
1 5/8	3 1/4	5 1/8	—	5 5/8

† LD Dimension is for double rod end models. See page 40.

Rod End Dimensions

Bore Size	Rod Dia (MM)	A	B - .001 to - .003	C	D	V	W	AB	KK Styles 2,4&6	RD (Max.)	RT	VB	WB
1 1/2	5/8	3/4	1.125	3/8	1/2**	1/4	5/8	10-32	7/16-20	1.972	.141	5/8	1
	1	1 1/8	1.500	1/2	7/8**	1/2	1	—	3/4-16	2.472	.313	7/8	1 3/8
2	5/8	3/4	1.125	3/8	1/2**	—	—	10-32	7/16-20	1.972	.141	5/8	1
	1	1 1/8	1.500	1/2	7/8**	1/2	1	1/4-28	3/4-16	2.472	.313	7/8	1 3/8
	1 3/8	1 5/8	2.000	5/8	1 1/8	5/8	1 1/4	—	1-14	2.972	.313	1	1 5/8
2 1/2	5/8	3/4	1.125	3/8	1/2**	—	—	10-32	7/16-20	1.972	.141	5/8	1
	1	1 1/8	1.500	1/2	7/8**	—	—	1/4-28	3/4-16	2.472	.313	7/8	1 3/8
	1 3/8	1 5/8	2.000	5/8	1 1/8	5/8	1 1/4	1/4-28	1-14	2.972	.313	1	1 5/8
3 1/4	1 3/4	2	2.375	3/4	1 1/2	3/4	1 1/2	—	1 1/4-12	3.470	.313	1 1/8	1 7/8
	1	1 1/8	1.500	1/2	7/8**	—	—	1/4-28	3/4-16	2.472	.313	7/8	1 3/8
	1 3/8	1 5/8	2.000	5/8	1 1/8	—	—	1/4-28	1-14	2.972	.313	1	1 5/8
4	1 3/8	1 5/8	2.000	5/8	1 1/8	—	—	1/4-28	1-14	2.972	.313	1	1 5/8
	1 3/4	2	2.375	3/4	1 1/2	—	—	1/4-28	1 1/4-12	3.470	.313	1 1/8	1 7/8
	2	2 1/4	2.625	7/8	1 11/16	1/2	1 3/8	1/4-28	1 1/2-12	3.720	.313	1 1/8	2
	2 1/2	3	3.125	1	2 1/16	5/8	1 5/8	1/4-28	1 7/8-12	4.252	.313	1 1/4	2 1/4
5	1 3/8	1 5/8	2.000	5/8	1 1/8	—	—	1/4-28	1-14	2.972	.313	1	1 5/8
	1 3/4	2	2.375	3/4	1 1/2	—	—	1/4-28	1 1/4-12	3.470	.313	1 1/8	1 7/8
	2	2 1/4	2.625	7/8	1 11/16	—	—	1/4-28	1 1/2-12	3.720	.313	1 1/8	2
	2 1/2	3	3.125	1	2 1/16	—	—	1/4-28	1 7/8-12	4.252	.313	1 1/4	2 1/4
	3	3 1/2	3.750	1	2 5/8	5/8	1 5/8	1/4-28	2 1/4-12	4.752	.313	1 1/4	2 1/4
6	3 1/2	3 1/2	4.250	1	3	5/8	1 5/8	1/4-28	2 1/2-12	5.252	.313	1 1/4	2 1/4
	1 3/8	1 5/8	2.000	5/8	1 1/8	—	—	1/4-28	1-14	2.972	.313	1	1 5/8
	1 3/4	2	2.375	3/4	1 1/2	—	—	1/4-28	1 1/4-12	3.470	.313	1 1/8	1 7/8
	2	2 1/4	2.625	7/8	1 11/16	—	—	1/4-28	1 1/2-12	3.720	.313	1 1/8	2
	2 1/2	3	3.125	1	2 1/16	—	—	1/4-28	1 7/8-12	4.252	.313	1 1/4	2 1/4
	3	3 1/2	3.750	1	2 5/8	—	—	1/4-28	2 1/4-12	4.752	.313	1 1/4	2 1/4
7	3 1/2	3 1/2	4.250	1	3	—	—	1/4-28	2 1/2-12	5.252	.313	1 1/4	2 1/4
	4	4	4.750	1	3 3/8	1/2	1 1/2	5/16-24	3-12	5.939	.610	1 1/4	2 1/4
	1 3/8	1 5/8	2.000	5/8	1 1/8	—	—	1/4-28	1-14	2.972	.313	1	1 5/8
	1 3/4	2	2.375	3/4	1 1/2	—	—	1/4-28	1 1/4-12	3.470	.313	1 1/8	1 7/8
	2	2 1/4	2.625	7/8	1 11/16	—	—	1/4-28	1 1/2-12	3.720	.313	1 1/8	2
	2 1/2	3	3.125	1	2 1/16	—	—	1/4-28	1 7/8-12	4.252	.313	1 1/4	2 1/4
	3	3 1/2	3.750	1	2 5/8	—	—	1/4-28	2 1/4-12	4.752	.313	1 1/4	2 1/4
	3 1/2	3 1/2	4.250	1	3	—	—	1/4-28	2 1/2-12	5.252	.313	1 1/4	2 1/4
	4	4	4.750	1	3 3/8	—	—	5/16-24	3-12	5.939	.610	1 1/4	2 1/4
4 1/2	4 1/2	5.250	1	3 7/8	—	—	5/16-24	3 1/4-12	6.439	.610	1 1/4	2 1/4	
5	5	5.750	1	4 1/4	—	—	5/16-24	3 1/2-12	6.939	.610	1 1/4	2 1/4	

** For Style #1 Rod End, 5/8 Rod Dia. — D=7/16". 1" Rod Dia. — D=1 1/16"

Stroke Plus

ZT	ZB
5 5/8	4 7/8
6	5 1/4
5 3/4	4 15/16
6 1/8	5 5/16
6 3/8	5 9/16
5 7/8	5 1/16
6 1/4	5 7/16
6 1/2	5 1 1/16
6 3/4	5 5/8
7	6
7 1/4	6 1/4
7 1/2	6 1/2
7 5/8	6 5/8
7 7/8	6 7/8
7 11/16	6 5/16
7 15/16	6 9/16
8 3/16	6 13/16
8 5/16	6 15/16
8 9/16	7 3/16
8 1/16	7 3/16
8 9/16	7 3/16
8 7/16	7 1/16
8 11/16	7 5/16
8 13/16	7 7/16
9 1/16	7 11/16
9 1/16	7 11/16
9 1/16	7 11/16
9 1/16	7 11/16
9 1/16	7 11/16
9 1/16	7 15/16
9 1/16	7 15/16
9 1/16	7 15/16
9 1/16	7 15/16
9 1/16	7 15/16
9 1/16	7 15/16

Tie Rod Mounts

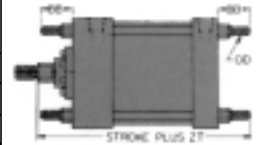

Tie Rods extended both sides
Model 51-B (NFPA MX1)

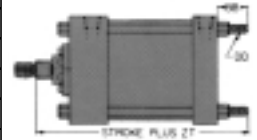

Tie Rods extended cap end
Model 52-B (NFPA MX2)

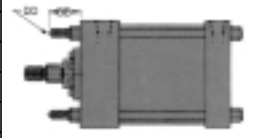

Tie Rods extended head end
Model 53-B (NFPA MX3)

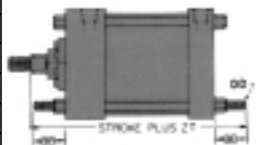

Tie Rods extended both ends
Model 54-B (NFPA MX4)

NOTE: For overall length on double rod-end cylinders, use overall length common dimension instead of "Stroke plus ZT" shown here, and add appropriate mounting dimensions. See page 40.

Miller Series A Air Cylinders & Series J Hydraulic Cylinders

Rectangular Flange/Head End
1 1/2" - 6" Bore Cylinders

Model 61-B (NFPA MF1) Bolted Bushing Rectangular Flange/Head End

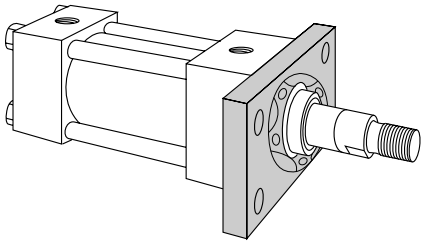

Note: High tensile mounting bolts should be used. Hardened flat washers should be used on 2 1/2" through 8" bore cylinders.

Mounting Dimensions (see tables on opposite page)

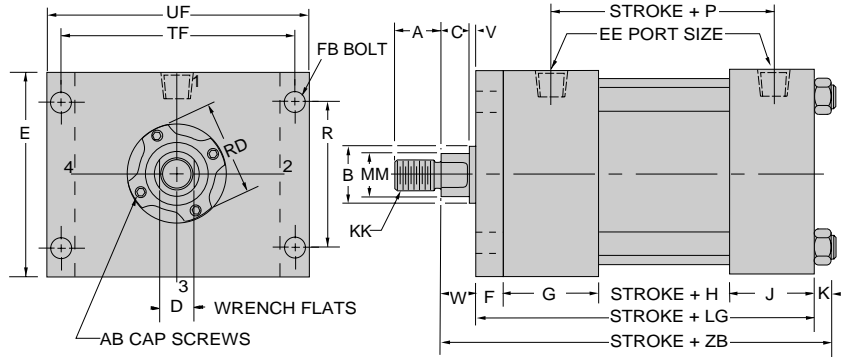

Model 61-R (NFPA MF1) Rectangular Retainer Rectangular Flange/Head End (1 1/2" - 6" Bores)

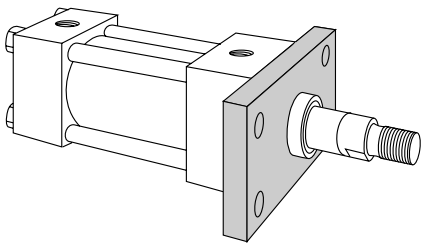

Note: High tensile mounting bolts should be used. Hardened flat washers should be used on 2 1/2" through 6" bore cylinders.

Mounting Dimensions (see tables on opposite page)

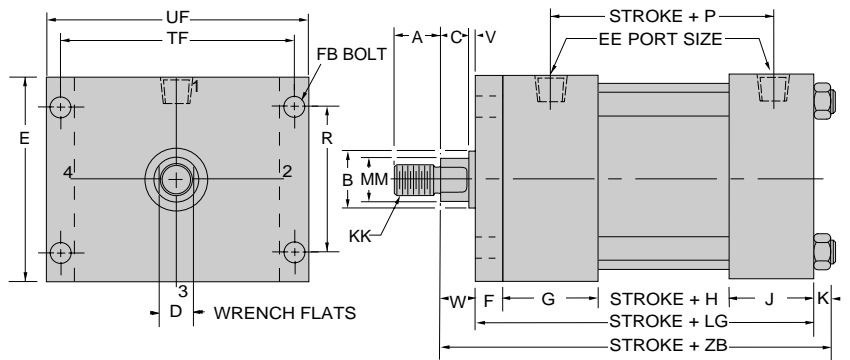

Note: To achieve higher pressure ratings in some size combinations, retainer construction can be furnished in lieu of standard bolted bushing construction. See pressure limitation chart for retainer held bushings on page 11.

Common Rod End Styles & Dimensions (See page 56 for complete listing of rod end styles.)

Style No. 2-Standard Threaded on Turndown Section

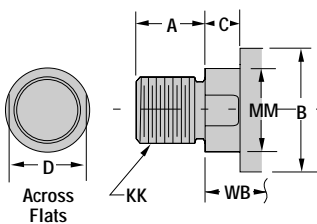

Style No. 4 Short Rod End-Internal Threads

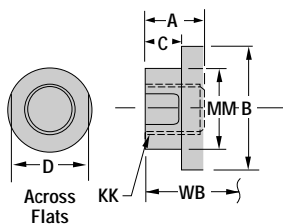

Style No. 6 Studded Rod End

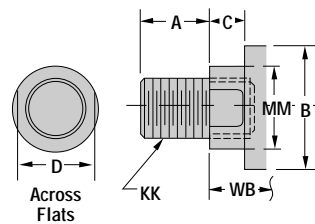

Pressure Limitations For Model 61 and 62 Flange Mount "J" Series Cylinders

Bore Size	1 1/2"		2"		2 1/2"		3 1/4"		4"		5"		6"	
	PSI Rating Mod.	PSI Rating Sev.	PSI Rating Mod.	PSI Rating Sev.	PSI Rating Mod.	PSI Rating Sev.	PSI Rating Mod.	PSI Rating Sev.	PSI Rating Mod.	PSI Rating Sev.	PSI Rating Mod.	PSI Rating Sev.	PSI Rating Mod.	PSI Rating Sev.
5/8	2500	1500	*770	*460	*950	*570								
1	1470	880	1430	850	*470	*280	*1670	*1000	*1500	*1000	*1200	*800		
1 3/8			770	460	950	570	*1100	*660	*1340	*800	*1110	*670	*1200	*800
1 3/4					660	400	1950	1170	*990	*590	*930	*560	*1200	*800
2							1670	1000	*910	*500	*880	*530	*1200	*800
2 1/2									1340	800	*680	*410	*1070	*640
3											*490	*290	*900	*540
3 1/2											690	410	*730	*440
4													920	550

* NOTE: "R" Construction is available to provide higher pressure ratings. Consult Application Engineering.

Miller Series A Air Cylinders & Series J Hydraulic Cylinders

Rectangular Flange/Head End 1½"– 6" Bore Cylinders

Model 61 Bolted Bushing and Retainer Construction – Through 6" Bore Only

Stroke Plus

Bore Size	E	EE	F	G	J	K	R	FB	TF	UF
1½	2	¾-18	¾	1½	1	¼	1.43	¼	2¾	3¾
2	2½	¾-18	¾	1½	1	⅝	1.84	⅝	3¾	4½
2½	3	¾-18	¾	1½	1	⅝	2.19	⅝	3¾	4⅝
3¼	3¾	1½-14	⅝	1¾	1¼	¾	2.76	¾	4⅞	5½
4	4½	1½-14	⅝	1¾	1¼	¾	3.32	¾	5⅞	6¼
5	5½	1½-14	⅝	1¾	1¼	¾	4.10	½	6⅝	7⅝
6	6½	¾-14	¾	2	1½	⅞	4.88	½	7⅝	8⅝

H	P	†LD	LG
1½	2¼	4⅞	4
1½	2¼	4⅞	4
1¼	2⅝	4¼	4⅞
1¼	2⅝	4¾	4⅞
1¼	2⅝	5	4⅞
1½	2⅞	5½	5⅞
1½	3⅞	5⅝	5¾

† LD Dimension is for double rod end models. See page 40.

Rod End Dimensions

Stroke Plus

Bore Size	Rod Dia (MM)	A	B -.001 to -.003	C	D	V	W	AB	KK Styles 2, 4&6	RD (Max.)	WB	ZB
1½	⅝	¾	1.125	¾	½**	¼	⅝	10-32	⅞-20	1.972	1	4⅞
	1	1⅞	1.500	½	⅞**	½	1	—	¾-16	2.472	1⅜	5¼
2	⅝	¾	1.125	¾	½**	—	—	10-32	⅞-20	1.972	1	4⅞
	1	1⅞	1.500	½	⅞**	½	1	¼-28	¾-16	2.472	1⅜	5⅞
2½	1⅜	1⅞	2.000	⅝	1⅞	⅝	1¼	—	1-14	2.972	1⅝	5⅞
	⅝	¾	1.125	¾	½**	—	—	10-32	⅞-20	1.972	—	5⅞
	1	1⅞	1.500	½	⅞**	—	—	¼-28	¾-16	2.472	1⅜	5⅞
3¼	1⅜	1⅞	2.000	⅝	1⅞	—	—	¼-28	1-14	2.972	1⅝	5⅞
	1⅜	1⅞	2.000	⅝	1⅞	—	—	¼-28	1-14	2.972	1⅝	5⅞
	1⅜	1⅞	2.000	⅝	1⅞	—	—	¼-28	1-14	2.972	1⅝	5⅞
4	1⅜	1⅞	2.000	⅝	1⅞	—	—	¼-28	1-14	2.972	1⅝	6
	1⅜	1⅞	2.000	⅝	1⅞	—	—	¼-28	1-14	2.972	1⅝	6¼
	1⅜	1⅞	2.000	⅝	1⅞	—	—	¼-28	1-14	2.972	1⅝	6¼
	1⅜	1⅞	2.000	⅝	1⅞	—	—	¼-28	1-14	2.972	1⅝	6¼
5	1⅜	1⅞	2.000	⅝	1⅞	—	—	¼-28	1-14	2.972	1⅝	6⅞
	1⅜	1⅞	2.000	⅝	1⅞	—	—	¼-28	1-14	2.972	1⅝	6⅞
	1⅜	1⅞	2.000	⅝	1⅞	—	—	¼-28	1-14	2.972	1⅝	6⅞
	1⅜	1⅞	2.000	⅝	1⅞	—	—	¼-28	1-14	2.972	1⅝	6⅞
6	1⅜	1⅞	2.000	⅝	1⅞	—	—	¼-28	1-14	2.972	1⅝	6⅞
	1⅜	1⅞	2.000	⅝	1⅞	—	—	¼-28	1-14	2.972	1⅝	6⅞
	1⅜	1⅞	2.000	⅝	1⅞	—	—	¼-28	1-14	2.972	1⅝	6⅞
	1⅜	1⅞	2.000	⅝	1⅞	—	—	¼-28	1-14	2.972	1⅝	6⅞
	1⅜	1⅞	2.000	⅝	1⅞	—	—	¼-28	1-14	2.972	1⅝	6⅞
	1⅜	1⅞	2.000	⅝	1⅞	—	—	¼-28	1-14	2.972	1⅝	6⅞
	1⅜	1⅞	2.000	⅝	1⅞	—	—	¼-28	1-14	2.972	1⅝	6⅞
7	1⅜	1⅞	2.000	⅝	1⅞	—	—	¼-28	1-14	2.972	1⅝	7⅞
	1⅜	1⅞	2.000	⅝	1⅞	—	—	¼-28	1-14	2.972	1⅝	7⅞
	1⅜	1⅞	2.000	⅝	1⅞	—	—	¼-28	1-14	2.972	1⅝	7⅞
	1⅜	1⅞	2.000	⅝	1⅞	—	—	¼-28	1-14	2.972	1⅝	7⅞
	1⅜	1⅞	2.000	⅝	1⅞	—	—	¼-28	1-14	2.972	1⅝	7⅞
	1⅜	1⅞	2.000	⅝	1⅞	—	—	¼-28	1-14	2.972	1⅝	7⅞
	1⅜	1⅞	2.000	⅝	1⅞	—	—	¼-28	1-14	2.972	1⅝	7⅞
	1⅜	1⅞	2.000	⅝	1⅞	—	—	¼-28	1-14	2.972	1⅝	7⅞
	1⅜	1⅞	2.000	⅝	1⅞	—	—	¼-28	1-14	2.972	1⅝	7⅞
	1⅜	1⅞	2.000	⅝	1⅞	—	—	¼-28	1-14	2.972	1⅝	7⅞

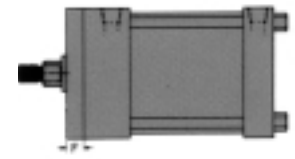
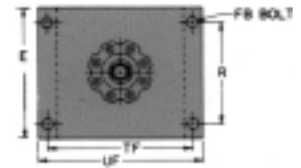

Rectangular Flange/Head End
Model 61-B (NFA MF1)

** For Style #1 Rod End, ⅝ Rod Dia. — D=⅞", 1" Rod Dia. — D=1⅞"

Miller Series A Air Cylinders & Series J Hydraulic Cylinders

Rectangular Flange/Cap End
1 1/2" - 6" Bore Cylinders

Model 62-B (NFPA MF2)
Bolted Bushing
Rectangular Flange/Cap End

Mounting Dimensions
(see tables on opposite page)

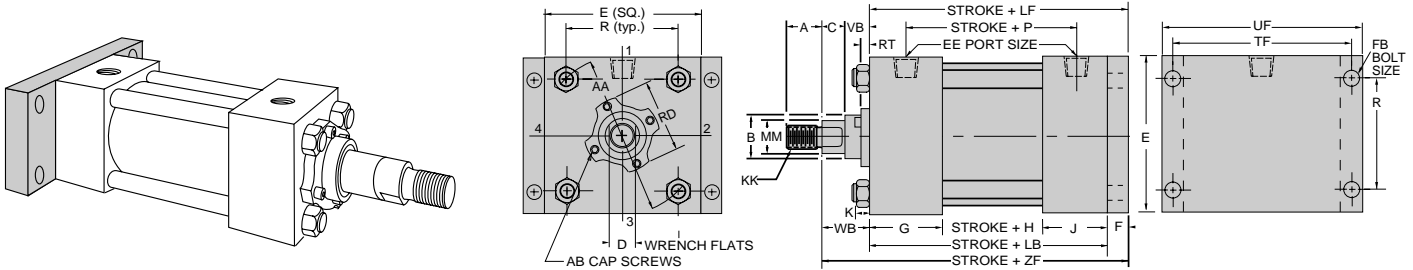

Note: High tensile mounting bolts should be used. Hardened flat washers should be used on 2 1/2" through 8" bore cylinders.

Model 62-R (NFPA MF2)
Square Retainer
Rectangular Flange/Cap End
(1 1/2" - 6" Bore)

Mounting Dimensions
(see tables on opposite page)

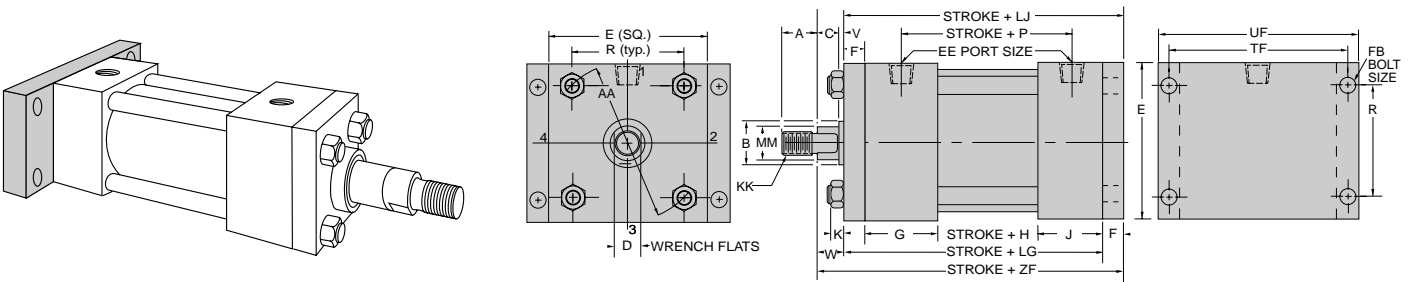

Note: High tensile mounting bolts should be used. Hardened flat washers should be used on 2 1/2" through 6" bore cylinders.

Common Rod End Styles & Dimensions (See page 56 for complete listing of rod end styles.)

Style No. 2 - Standard
Threaded on Turndown Section

Style No. 4
Short Rod End-Internal Threads

Style No. 6
Studded Rod End

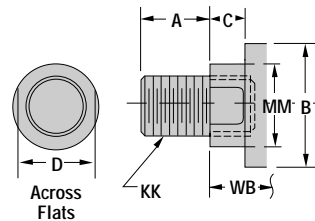
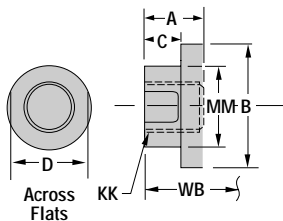
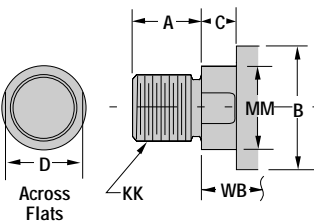

Pressure Limitations For Model 61 and 62 Flange Mount "J" Series Cylinders

Bore Size	1 1/2"		2"		2 1/2"		3 1/4"		4"		5"		6"	
	PSI Rating	PSI Rating	PSI Rating	PSI Rating	PSI Rating	PSI Rating	PSI Rating	PSI Rating	PSI Rating	PSI Rating	PSI Rating	PSI Rating	PSI Rating	PSI Rating
Piston Rod Diameter	Mod.	Sev.	Mod.	Sev.	Mod.	Sev.	Mod.	Sev.	Mod.	Sev.	Mod.	Sev.	Mod.	Sev.
5/8	2500	1500	*770	*460	*950	*570								
1	1470	880	1430	850	*470	*280	*1670	*1000	*1500	*1000	*1200	*800		
1 3/8			770	460	950	570	*1100	*660	*1340	*800	*1110	*670	*1200	*800
1 3/4					660	400	1950	1170	*990	*590	*930	*560	*1200	*800
2							1670	1000	*910	*500	*880	*530	*1200	*800
2 1/2									1340	800	*680	*410	*1070	*640
3											*490	*290	*900	*540
3 1/2											690	410	*730	*440
4													920	550

* NOTE: "R" Construction is available to provide higher pressure ratings. Consult Application Engineering.

Miller Series A Air Cylinders & Series J Hydraulic Cylinders

Rectangular Flange/Cap End
1 1/2" – 6" Bore Cylinders

Model 62 Bolted Bushing and Retainer Construction – Through 6" Bore Only

Stroke Plus

Bore Size	AA	E	EE	F	G	J	K	R	FB	TF	UF	LJ	H	P	LB	LG	LF
1 1/2	2.02	2	3/8-18	3/8	1 1/2	1	1/4	1.43	1/4	2 3/4	3 3/8	4 3/8	1 1/8	2 1/4	3 5/8	4	4
2	2.60	2 1/2	3/8-18	3/8	1 1/2	1	5/16	1.84	5/16	3 3/8	4 1/8	4 3/8	1 1/8	2 1/4	3 5/8	4	4
2 1/2	3.10	3	3/8-18	3/8	1 1/2	1	5/16	2.19	5/16	3 3/8	4 5/8	4 1/2	1 1/4	2 3/8	3 3/4	4 7/8	4 7/8
3 1/4	3.90	3 3/4	1/2-14	5/8	1 3/4	1 1/4	3/8	2.76	3/8	4 1 1/16	5 1/2	5 1/2	1 1/4	2 5/8	4 1/4	4 7/8	4 7/8
4	4.70	4 1/2	1/2-14	5/8	1 3/4	1 1/4	3/8	3.32	3/8	5 7/16	6 1/4	5 1/2	1 1/4	2 5/8	4 1/4	4 7/8	4 7/8
5	5.80	5 1/2	1/2-14	5/8	1 3/4	1 1/4	7/16	4.10	1/2	6 5/8	7 5/8	5 3/4	1 1/2	2 7/8	4 1/2	5 1/8	5 1/8
6	6.90	6 1/2	3/4-14	3/4	2	1 1/2	7/16	4.88	1/2	7 5/8	8 5/8	6 1/2	1 1/2	3 1/8	5	5 3/4	5 3/4

Rod End Dimensions

Stroke Plus

Bore Size	Rod Dia (MM)	A	B -.001 to -.003	C	D	V	W	AB	KK Styles 2,4&6	RD (Max.)	RT	VB	WB	ZF
1 1/2	5/8	3/4	1.125	3/8	1/2**	1/4	5/8	10-32	7/16-20	1.972	.141	5/8	1	5
	1	1 1/8	1.500	1/2	7/8**	1/2	1	—	3/4-16	2.472	.313	7/8	1 3/8	5 3/8
2	5/8	3/4	1.125	3/8	1/2**	—	—	10-32	7/16-20	1.972	.141	5/8	1	5
	1	1 1/8	1.500	1/2	7/8**	1/2	1	1/4-28	3/4-16	2.472	.313	7/8	1 3/8	5 3/8
	1 3/8	1 5/8	2.000	5/8	1 1/8	5/8	1 1/4	—	1-14	2.972	.313	1	1 5/8	5 5/8
2 1/2	5/8	3/4	1.125	3/8	1/2**	—	—	10-32	7/16-20	1.972	.141	5/8	1	5 1/8
	1	1 1/8	1.500	1/2	7/8**	—	—	1/4-28	3/4-16	2.472	.313	7/8	1 3/8	5 1/2
	1 3/8	1 5/8	2.000	5/8	1 1/8	5/8	1 1/4	1/4-28	1-14	2.972	.313	1	1 5/8	5 3/4
	1 3/4	2	2.375	3/4	1 1/2	3/4	1 1/2	—	1 1/4-12	3.470	.313	1 1/8	1 7/8	6
3 1/4	1	1 1/8	1.500	1/2	7/8**	—	—	1/4-28	3/4-16	2.472	.313	7/8	1 3/8	6 1/4
	1 3/8	1 5/8	2.000	5/8	1 1/8	—	—	1/4-28	1-14	2.972	.313	1	1 5/8	6 1/2
	1 3/4	2	2.375	3/4	1 1/2	1/2	1 1/4	1/4-28	1 1/4-12	3.470	.313	1 1/8	1 7/8	6 3/4
	2	2 1/4	2.625	7/8	1 1 1/16	1/2	1 3/8	1/4-28	1 1/2-12	3.720	.313	1 1/8	2	6 7/8
4	1	1 1/8	1.500	1/2	7/8**	—	—	1/4-28	3/4-16	2.472	.313	7/8	1 3/8	6 1/4
	1 3/8	1 5/8	2.000	5/8	1 1/8	—	—	1/4-28	1-14	2.972	.313	1	1 5/8	6 1/2
	1 3/4	2	2.375	3/4	1 1/2	—	—	1/4-28	1 1/4-12	3.470	.313	1 1/8	1 7/8	6 3/4
	2	2 1/4	2.625	7/8	1 1 1/16	—	—	1/4-28	1 1/2-12	3.720	.313	1 1/8	2	6 7/8
	2 1/2	3	3.125	1	2 1/16	5/8	1 5/8	1/4-28	1 7/8-12	4.252	.313	1 1/4	2 1/4	7 1/8
5	1	1 1/8	1.500	1/2	7/8**	—	—	1/4-28	3/4-16	2.472	.313	7/8	1 3/8	6 1/2
	1 3/8	1 5/8	2.000	5/8	1 1/8	—	—	1/4-28	1-14	2.972	.313	1	1 5/8	6 3/4
	1 3/4	2	2.375	3/4	1 1/2	—	—	1/4-28	1 1/4-12	3.470	.313	1 1/8	1 7/8	7
	2	2 1/4	2.625	7/8	1 1 1/16	—	—	1/4-28	1 1/2-12	3.720	.313	1 1/8	2	7 1/8
	2 1/2	3	3.125	1	2 1/16	—	—	1/4-28	1 7/8-12	4.252	.313	1 1/4	2 1/4	7 3/8
	3	3 1/2	3.750	1	2 5/8	5/8	1 5/8	1/4-28	2 1/4-12	4.752	.313	1 1/4	2 1/4	7 3/8
	3 1/2	3 1/2	4.250	1	3	5/8	1 5/8	1/4-28	2 1/2-12	5.252	.313	1 1/4	2 1/4	7 3/8
6	1 3/8	1 5/8	2.000	5/8	1 1/8	—	—	1/4-28	1-14	2.972	.313	1	1 5/8	7 3/8
	1 3/4	2	2.375	3/4	1 1/2	—	—	1/4-28	1 1/4-12	3.470	.313	1 1/8	1 7/8	7 5/8
	2	2 1/4	2.625	7/8	1 1 1/16	—	—	1/4-28	1 1/2-12	3.720	.313	1 1/8	2	7 3/4
	2 1/2	3	3.125	1	2 1/16	—	—	1/4-28	1 7/8-12	4.252	.313	1 1/4	2 1/4	8
	3	3 1/2	3.750	1	2 5/8	—	—	1/4-28	2 1/4-12	4.752	.313	1 1/4	2 1/4	8
	3 1/2	3 1/2	4.250	1	3	—	—	1/4-28	2 1/2-12	5.252	.313	1 1/4	2 1/4	8
	4	4	4.750	1	3 3/8	1/2	1 1/2	5/16-24	3-12	5.939	.610	1 1/4	2 1/4	8
	1 3/8	1 5/8	2.000	5/8	1 1/8	—	—	1/4-28	1-14	2.972	.313	1	1 5/8	N/A
7	1 3/4	2	2.375	3/4	1 1/2	—	—	1/4-28	1 1/4-12	3.470	.313	1 1/8	1 7/8	N/A
	2	2 1/4	2.625	7/8	1 1 1/16	—	—	1/4-28	1 1/2-12	3.720	.313	1 1/8	2	N/A
	2 1/2	3	3.125	1	2 1/16	—	—	1/4-28	1 7/8-12	4.252	.313	1 1/4	2 1/4	N/A
	3	3 1/2	3.750	1	2 5/8	—	—	1/4-28	2 1/4-12	4.752	.313	1 1/4	2 1/4	N/A
	3 1/2	3 1/2	4.250	1	3	—	—	1/4-28	2 1/2-12	5.252	.313	1 1/4	2 1/4	N/A
	4	4	4.750	1	3 3/8	—	—	5/16-24	3-12	5.939	.610	1 1/4	2 1/4	N/A
	4 1/2	4 1/2	5.250	1	3 7/8	—	—	5/16-24	3 3/4-12	6.439	.610	1 1/4	2 1/4	N/A
	5	5	5.750	1	4 1/4	—	—	5/16-24	3 1/2-12	6.939	.610	1 1/4	2 1/4	N/A

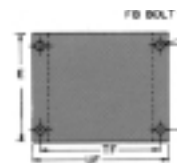
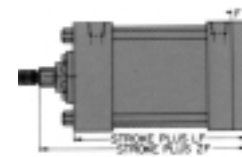

Rectangular Flange/Cap End
Model 62-B (NFPA MF2)

** For Style #1 Rod End, 5/8 Rod Dia. — D=7/16". 1" Rod Dia. — D=13/16"

Miller Series A Air Cylinders & Series J Hydraulic Cylinders

Square Flange/Head End
1 1/2" - 6" Bore Cylinders

Model 65-B (NFPA MF5) Bolted Bushing Square Flange/Head End

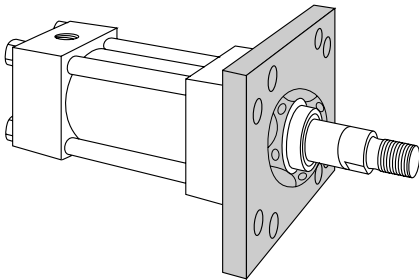

Note: High tensile mounting bolts should be used. Hardened flat washers should be used on 2 1/2" through 8" bore cylinders.

Mounting Dimensions (See tables on opposite page)

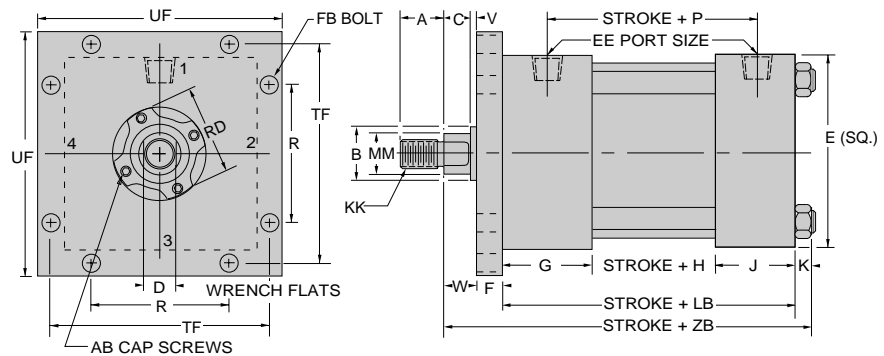

Model 65-R (NFPA MF5) Square Retainer Held Bushing Square Flange/Head End

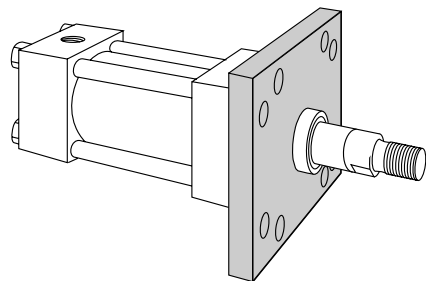

Note: High tensile mounting bolts should be used. Hardened flat washers should be used on 2 1/2" through 8" bore cylinders.

Mounting Dimensions (See tables on opposite page)

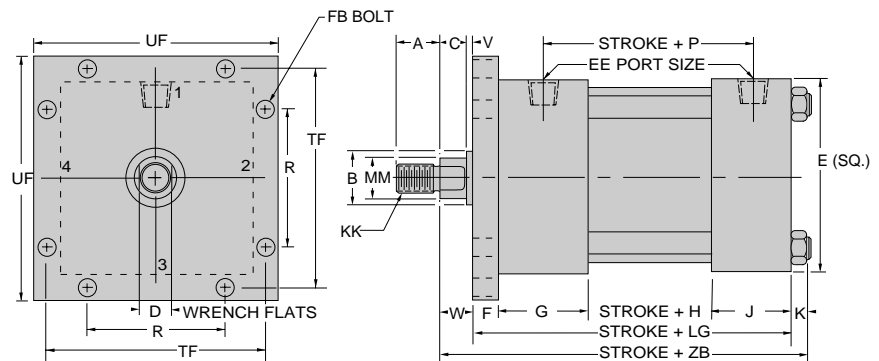

Common Rod End Styles & Dimensions (See page 56 for complete listing of rod end styles.)

Style No. 2-Standard
Threaded on Turndown Section

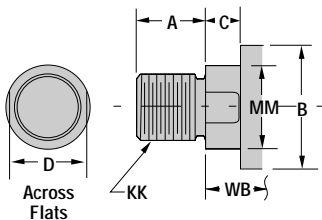

Style No. 4
Short Rod End-Internal Threads

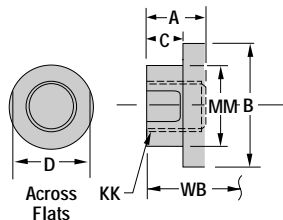

Style No. 6
Studded Rod End

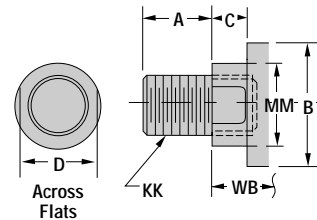

Miller Series A Air Cylinders & Series J Hydraulic Cylinders

Square Flange/Head End
1 1/2" – 6" Bore Cylinders

Model 65 Bolted Bushing and Retainer Construction – Through 6" Bore Only

Stroke Plus

Bore Size	E	EE	F	G	J	K	R	FB	TF	UF	H	P	LB	LG
1 1/2	2	3/8-18	3/8	1 1/2	1	1/4	1.43	1/4	2 3/4	3 3/8	1 1/8	2 1/4	3 5/8	4
2	2 1/2	3/8-18	3/8	1 1/2	1	5/16	1.84	5/16	3 3/8	4 1/8	1 1/8	2 1/4	3 5/8	4
2 1/2	3	3/8-18	3/8	1 1/2	1	5/16	2.19	5/16	3 7/8	4 5/8	1 1/4	2 3/8	3 3/4	4 1/8
3 1/4	3 3/4	1/2-14	5/8	1 3/4	1 1/4	3/8	2.76	3/8	4 11/16	5 1/2	1 1/4	2 5/8	4 1/4	4 7/8
4	4 1/2	1/2-14	5/8	1 3/4	1 1/4	3/8	3.32	3/8	5 7/16	6 1/4	1 1/4	2 5/8	4 1/4	4 7/8
5	5 1/2	1/2-14	5/8	1 3/4	1 1/4	7/16	4.10	1/2	6 5/8	7 5/8	1 1/2	2 7/8	4 1/2	5 1/8
6	6 1/2	3/4-14	3/4	2	1 1/2	7/16	4.88	1/2	7 5/8	8 5/8	1 1/2	3 1/8	5	5 3/4

Rod End Dimensions

Stroke Plus

Bore Size	Rod Dia (MM)	A	B -.001 to -.003	C	D	V	W	AB	KK Styles 2,4&6	RD (Max.)	WB	ZB
1 1/2	5/8	3/4	1.125	3/8	1/2**	1/4	5/8	10-32	7/16-20	1.972	1	4 7/8
	1	1 1/8	1.500	1/2	7/8**	1/2	1	—	3/4-16	2.472	1 3/8	5 1/4
2	5/8	3/4	1.125	3/8	1/2**	—	—	10-32	7/16-20	1.972	1	4 15/16
	1	1 1/8	1.500	1/2	7/8**	1/2	1	1/4-28	3/4-16	2.472	1 3/8	5 5/16
2 1/2	1 3/8	1 5/8	2.000	5/8	1 1/8	5/8	1 1/4	—	1-14	2.972	1 5/8	5 9/16
	5/8	3/4	1.125	3/8	1/2**	—	—	10-32	7/16-20	1.972	1	5 1/16
2 1/2	1	1 1/8	1.500	1/2	7/8**	—	—	1/4-28	3/4-16	2.472	1 3/8	5 7/16
	1 3/8	1 5/8	2.000	5/8	1 1/8	5/8	1 1/4	1/4-28	1-14	2.972	1 5/8	5 11/16
3 1/4	1 3/4	2	2.375	3/4	1 1/2	3/4	1 1/2	—	1 1/4-12	3.470	1 7/8	5 15/16
	1	1 1/8	1.500	1/2	7/8**	—	—	1/4-28	3/4-16	2.472	1 3/8	6
3 1/4	1 3/8	1 5/8	2.000	5/8	1 1/8	—	—	1/4-28	1-14	2.972	1 5/8	6 1/4
	1 3/4	2	2.375	3/4	1 1/2	1/2	1 1/4	1/4-28	1 1/4-12	3.470	1 7/8	6 1/2
4	2	2 1/4	2.625	7/8	1 11/16	1/2	1 3/8	1/4-28	1 1/2-12	3.720	2	6 5/8
	1	1 1/8	1.500	1/2	7/8**	—	—	1/4-28	3/4-16	2.472	1 3/8	6
4	1 3/8	1 5/8	2.000	5/8	1 1/8	—	—	1/4-28	1-14	2.972	1 5/8	6 1/4
	1 3/4	2	2.375	3/4	1 1/2	—	—	1/4-28	1 1/4-12	3.470	1 7/8	6 1/2
5	2	2 1/4	2.625	7/8	1 11/16	—	—	1/4-28	1 1/2-12	3.720	2	6 5/8
	2 1/2	3	3.125	1	2 1/16	5/8	1 5/8	1/4-28	1 7/8-12	4.252	2 1/4	6 7/8
5	1	1 1/8	1.500	1/2	7/8**	—	—	1/4-28	3/4-16	2.472	1 3/8	6 5/16
	1 3/8	1 5/8	2.000	5/8	1 1/8	—	—	1/4-28	1-14	2.972	1 5/8	6 9/16
5	1 3/4	2	2.375	3/4	1 1/2	—	—	1/4-28	1 1/4-12	3.470	1 7/8	6 13/16
	2	2 1/4	2.625	7/8	1 11/16	—	—	1/4-28	1 1/2-12	3.720	2	6 15/16
5	2 1/2	3	3.125	1	2 1/16	—	—	1/4-28	1 7/8-12	4.252	2 1/4	7 3/16
	3	3 1/2	3.750	1	2 5/8	5/8	1 5/8	1/4-28	2 1/4-12	4.752	2 1/4	7 3/16
6	3 1/2	3 1/2	4.250	1	3	5/8	1 5/8	1/4-28	2 1/2-12	5.252	2 1/4	7 3/16
	1 3/8	1 5/8	2.000	5/8	1 1/8	—	—	1/4-28	1-14	2.972	1 5/8	7 1/16
6	1 3/4	2	2.375	3/4	1 1/2	—	—	1/4-28	1 1/4-12	3.470	1 7/8	7 5/16
	2	2 1/4	2.625	7/8	1 11/16	—	—	1/4-28	1 1/2-12	3.720	2	7 7/16
6	2 1/2	3	3.125	1	2 1/16	—	—	1/4-28	1 7/8-12	4.252	2 1/4	7 11/16
	3	3 1/2	3.750	1	2 5/8	—	—	1/4-28	2 1/4-12	4.752	2 1/4	7 11/16
6	3 1/2	3 1/2	4.250	1	3	—	—	1/4-28	2 1/2-12	5.252	2 1/4	7 11/16
	4	4	4.750	1	3 3/8	1/2	1 1/2	5/16-24	3-12	5.939	2 1/4	7 11/16
7	1 3/8	1 5/8	2.000	5/8	1 1/8	—	—	1/4-28	1-14	2.972	1 5/8	7 5/16
	1 3/4	2	2.375	3/4	1 1/2	—	—	1/4-28	1 1/4-12	3.470	1 7/8	7 9/16
7	2	2 1/4	2.625	7/8	1 11/16	—	—	1/4-28	1 1/2-12	3.720	2	7 11/16
	2 1/2	3	3.125	1	2 1/16	—	—	1/4-28	1 7/8-12	4.252	2 1/4	7 15/16
7	3	3 1/2	3.750	1	2 5/8	—	—	1/4-28	2 1/4-12	4.752	2 1/4	7 15/16
	3 1/2	3 1/2	4.250	1	3	—	—	1/4-28	2 1/2-12	5.252	2 1/4	7 15/16
7	4	4	4.750	1	3 3/8	—	—	5/16-24	3-12	5.939	2 1/4	7 15/16
	4 1/2	4 1/2	5.250	1	3 7/8	—	—	5/16-24	3 1/4-12	6.439	2 1/4	7 15/16
7	5	5	5.750	1	4 1/4	—	—	5/16-24	3 1/2-12	6.939	2 1/4	7 15/16

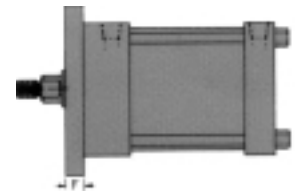
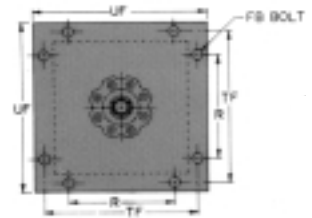

Square Flange/Head End
Model 65-B (NFA MF5)

** For Style #1 Rod End, 5/8 Rod Dia. — D=7/16". 1" Rod Dia. — D=13/16"

Miller Series A Air Cylinders & Series J Hydraulic Cylinders

Square Flange/Cap End
1 1/2" - 6" Bore Cylinders

Model 66-B (NFPA MF6) Bolted Bushing Square Flange/Cap End

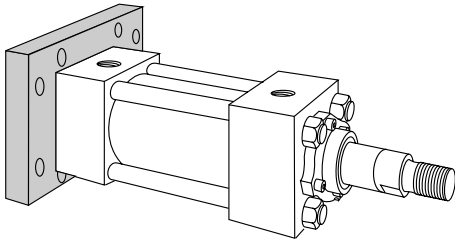

Mounting Dimensions (See tables on opposite page)

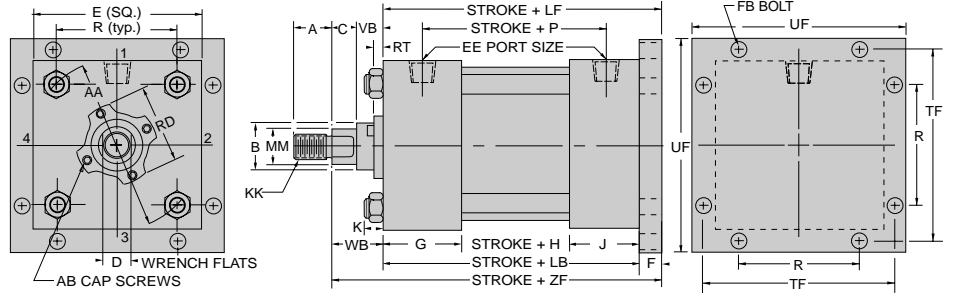

Note: High tensile mounting bolts should be used. Hardened flat washers should be used on 2 1/2" through 8" bore cylinders.

Model 66-R (NFPA MF6) Square Retainer Held Bushing Square Flange/Cap End

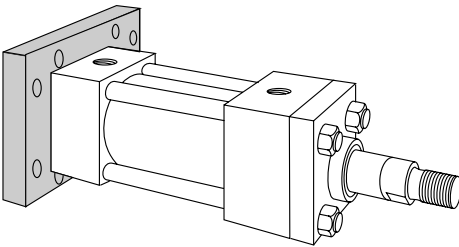

Mounting Dimensions (See tables on opposite page)

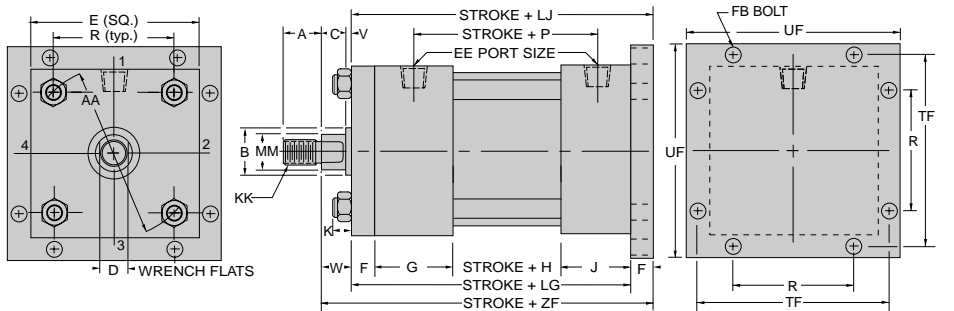

Note: High tensile mounting bolts should be used. Hardened flat washers should be used on 2 1/2" through 8" bore cylinders.

Common Rod End Styles & Dimensions (See page 56 for complete listing of rod end styles.)

Style No. 2-Standard Threaded on Turndown Section

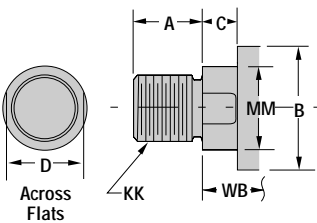

Style No. 4 Short Rod End-Internal Threads

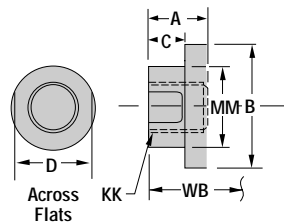

Style No. 6 Studded Rod End

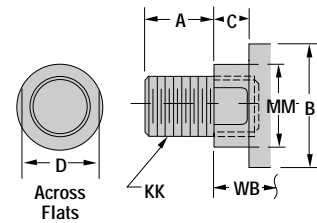

Miller Series A Air Cylinders & Series J Hydraulic Cylinders

Square Flange/Cap End
1½" – 6" Bore Cylinders

Model 66 Bolted Bushing and Retainer Construction – Through 6" Bore Only

Stroke Plus

Bore Size	AA	E	EE	F	G	J	K	R	FB	TF	UF	LJ	H	P	LB	LG	LF
1½	2.02	2	¾-18	¾	1½	1	¼	1.43	¼	2¾	3¾	4¾	1½	2¼	3⅝	4	4
2	2.60	2½	¾-18	¾	1½	1	⅝	1.84	⅝	3¾	4¼	4¾	1½	2¼	3⅝	4	4
2½	3.10	3	¾-18	¾	1½	1	⅝	2.19	⅝	3⅞	4⅝	4½	1¼	2⅜	3¾	4⅞	4⅞
3¼	3.90	3¾	½-14	⅝	1¾	1¼	¾	2.76	¾	4⅞	5½	5½	1¼	2⅝	4¼	4⅞	4⅞
4	4.70	4½	½-14	⅝	1¾	1¼	¾	3.32	¾	5⅞	6¼	5½	1¼	2⅝	4¼	4⅞	4⅞
5	5.80	5½	½-14	⅝	1¾	1¼	⅞	4.10	½	6⅝	7⅝	5¾	1½	2⅞	4½	5⅞	5⅞
6	6.90	6½	¾-14	¾	2	1½	⅞	4.88	½	7⅝	8⅝	6½	1½	3⅞	5	5¾	5¾

Rod End Dimensions

Stroke Plus

Bore Size	Rod Dia (MM)	A	B -.001 to -.003	C	D	V	W	AB	KK Styles 2,4&6	RD (Max.)	RT	VB	WB	ZF
1½	⅝	¾	1.125	¾	½**	¼	⅝	10-32	⅞-20	1.972	.141	⅝	1	5
	1	1⅞	1.500	½	⅞**	½	1	—	¾-16	2.472	.313	⅞	1⅞	5⅝
2	⅝	¾	1.125	¾	½**	—	—	10-32	⅞-20	1.972	.141	⅝	1	5
	1	1⅞	1.500	½	⅞**	½	1	¼-28	¾-16	2.472	.313	⅞	1⅞	5⅝
	1⅜	1⅝	2.000	⅝	1⅞	⅝	1¼	—	1-14	2.972	.313	1	1⅝	5⅝
2½	⅝	¾	1.125	¾	½**	—	—	10-32	⅞-20	1.972	.141	⅝	1	5⅞
	1	1⅞	1.500	½	⅞**	—	—	¼-28	¾-16	2.472	.313	⅞	1⅞	5½
	1⅜	1⅝	2.000	⅝	1⅞	⅝	1¼	¼-28	1-14	2.972	.313	1	1⅝	5¾
	1¾	2	2.375	¾	1½	¾	1½	—	1¼-12	3.470	.313	1⅞	1⅞	6
3¼	1	1⅞	1.500	½	⅞**	—	—	¼-28	¾-16	2.472	.313	⅞	1⅞	6¼
	1⅜	1⅝	2.000	⅝	1⅞	—	—	¼-28	1-14	2.972	.313	1	1⅝	6½
	1¾	2	2.375	¾	1½	½	1¼	¼-28	1¼-12	3.470	.313	1⅞	1⅞	6¾
	2	2¼	2.625	⅞	1⅞	½	1⅜	¼-28	1½-12	3.720	.313	1⅞	2	6⅞
4	1	1⅞	1.500	½	⅞**	—	—	¼-28	¾-16	2.472	.313	⅞	1⅞	6¼
	1⅜	1⅝	2.000	⅝	1⅞	—	—	¼-28	1-14	2.972	.313	1	1⅝	6½
	1¾	2	2.375	¾	1½	—	—	¼-28	1¼-12	3.470	.313	1⅞	1⅞	6¾
	2	2¼	2.625	⅞	1⅞	—	—	¼-28	1½-12	3.720	.313	1⅞	2	6⅞
	2½	3	3.125	1	2⅞	⅝	1⅝	¼-28	1⅞-12	4.252	.313	1¼	2¼	7⅞
	3	3½	3.750	1	3	⅝	1⅝	¼-28	2⅞-12	5.252	.313	1¼	2¼	7⅞
5	1	1⅞	1.500	½	⅞**	—	—	¼-28	¾-16	2.472	.313	⅞	1⅞	6½
	1⅜	1⅝	2.000	⅝	1⅞	—	—	¼-28	1-14	2.972	.313	1	1⅝	6¾
	1¾	2	2.375	¾	1½	—	—	¼-28	1¼-12	3.470	.313	1⅞	1⅞	7
	2	2¼	2.625	⅞	1⅞	—	—	¼-28	1½-12	3.720	.313	1⅞	2	7⅞
	2½	3	3.125	1	2⅞	—	—	¼-28	1⅞-12	4.252	.313	1¼	2¼	7⅞
	3	3½	3.750	1	3	⅝	1⅝	¼-28	2⅞-12	4.752	.313	1¼	2¼	7⅞
	3½	3½	4.250	1	3	⅝	1⅝	¼-28	2⅞-12	5.252	.313	1¼	2¼	7⅞
6	1⅜	1⅝	2.000	⅝	1⅞	—	—	¼-28	1-14	2.972	.313	1	1⅝	7⅞
	1¾	2	2.375	¾	1½	—	—	¼-28	1¼-12	3.470	.313	1⅞	1⅞	7⅞
	2	2¼	2.625	⅞	1⅞	—	—	¼-28	1½-12	3.720	.313	1⅞	2	7¾
	2½	3	3.125	1	2⅞	—	—	¼-28	1⅞-12	4.252	.313	1¼	2¼	8
	3	3½	3.750	1	3	—	—	¼-28	2¼-12	4.752	.313	1¼	2¼	8
	3½	3½	4.250	1	3	—	—	¼-28	2½-12	5.252	.313	1¼	2¼	8
	4	4	4.750	1	3⅞	½	1½	⅝-24	3-12	5.939	.610	1¼	2¼	8
	4½	4½	5.250	1	4	—	—	⅝-24	3½-12	6.439	.610	1¼	2¼	N/A
7	1⅜	1⅝	2.000	⅝	1⅞	—	—	¼-28	1-14	2.972	.313	1	1⅝	N/A
	1¾	2	2.375	¾	1½	—	—	¼-28	1¼-12	3.470	.313	1⅞	1⅞	N/A
	2	2¼	2.625	⅞	1⅞	—	—	¼-28	1½-12	3.720	.313	1⅞	2	N/A
	2½	3	3.125	1	2⅞	—	—	¼-28	1⅞-12	4.252	.313	1¼	2¼	N/A
	3	3½	3.750	1	3	—	—	¼-28	2¼-12	4.752	.313	1¼	2¼	N/A
	3½	3½	4.250	1	3	—	—	¼-28	2½-12	5.252	.313	1¼	2¼	N/A
	4	4	4.750	1	3⅞	—	—	⅝-24	3-12	5.939	.610	1¼	2¼	N/A
	4½	4½	5.250	1	4	—	—	⅝-24	3½-12	6.439	.610	1¼	2¼	N/A
5	5	5.750	1	4¼	—	—	⅝-24	3½-12	6.939	.610	1¼	2¼	N/A	

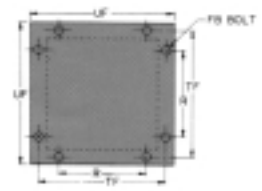
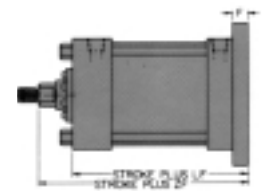

Square Flange/Cap End Model 66-B (NFPA MF6)

** For Style #1 Rod End, ⅝ Rod Dia. — D=⅞". 1" Rod Dia. — D=1⅜"

Miller Series A Air Cylinders & Series J Hydraulic Cylinders

Rectangular Head/Cap
1 1/2" - 7" Bore Cylinders

Model 67-B (NFPA ME5) Bolted Bushing Rectangular Head

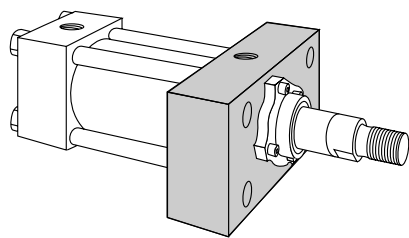

Mounting Dimensions (See tables on opposite page)

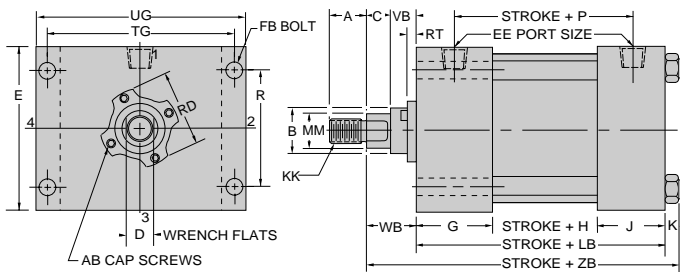

Note: High tensile mounting bolts should be used. Hardened flat washers should be used on 2 1/2" through 7" bore cylinders. Not available in Retainer Held Bushing construction.

Model 68-B (NFPA ME6) Bolted Bushing Rectangular Cap

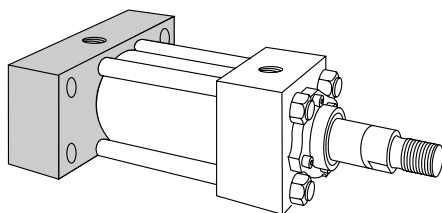

Mounting Dimensions (See tables on opposite page)

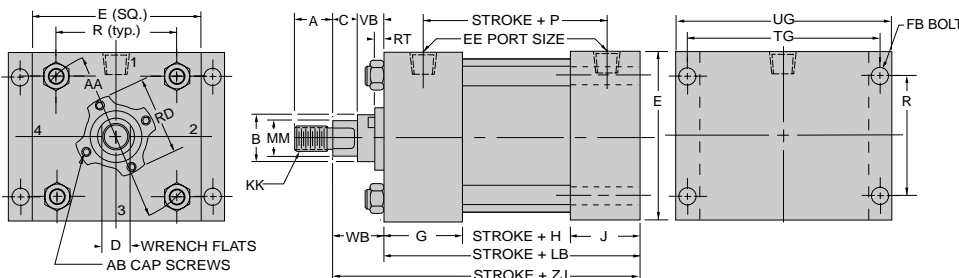

Note: High tensile mounting bolts should be used. Hardened flat washers should be used on 2 1/2" through 7" bore cylinders.

Model 68-R (NFPA ME6) Square Retainer Held Bushing Rectangular Cap End

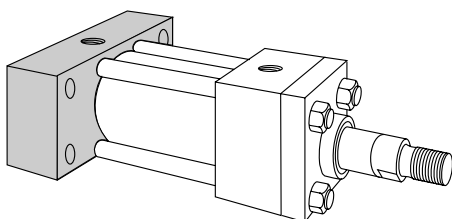

Mounting Dimensions (See tables on opposite page)

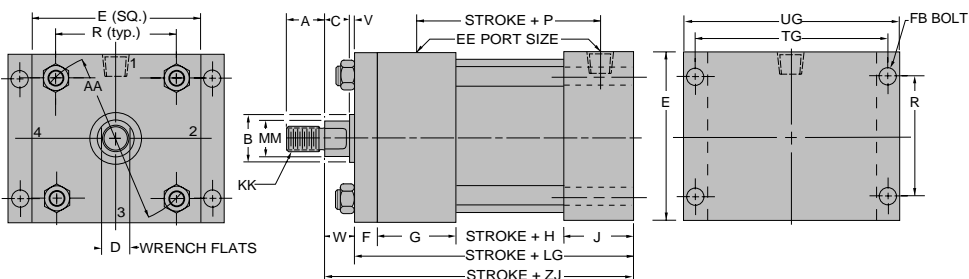

Note: High tensile mounting bolts should be used. Hardened flat washers should be used on 2 1/2" through 7" bore cylinders.

Common Rod End Styles & Dimensions (See page 56 for complete listing of rod end styles.)

Style No. 2-Standard Threaded on Turndown Section

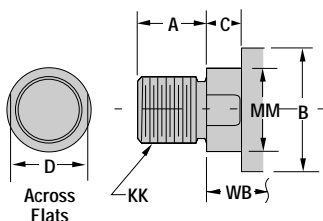

Style No. 4 Short Rod End-Internal Threads

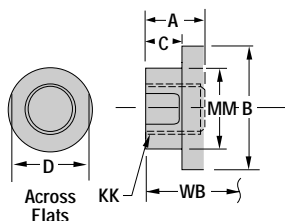

Style No. 6 Studded Rod End

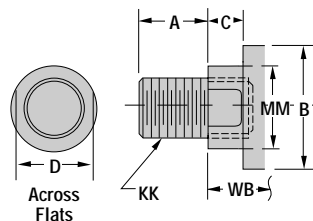

Miller Series A Air Cylinders & Series J Hydraulic Cylinders

Side Lug
1½" – 7" Bore Cylinders

Model 72-B (NFPA MS2) Bolted Bushing Side Lug

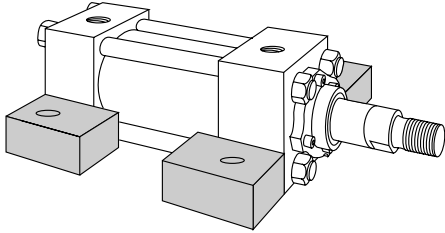

Mounting Dimensions (See tables on opposite page)

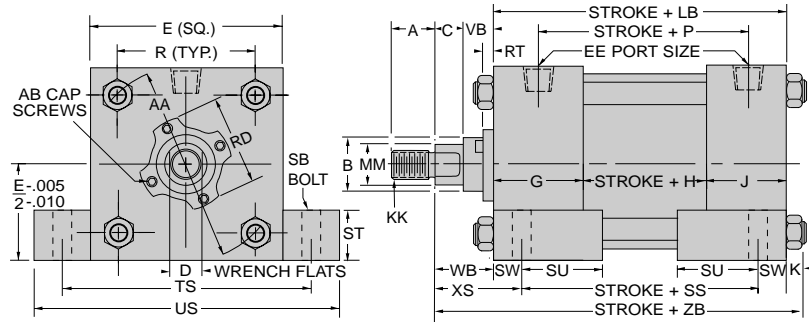

Note: Lugs should be blocked, or a "K" retainer should be mounted on the appropriate end to absorb hydraulic or mechanical shock. Bolts should not carry shear load.

Model 72-R (NFPA MS2) Square Retainer Held Bushing Side Lug

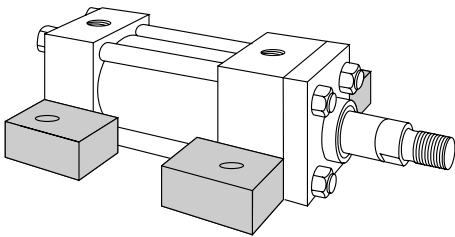

Mounting Dimensions (See tables on opposite page)

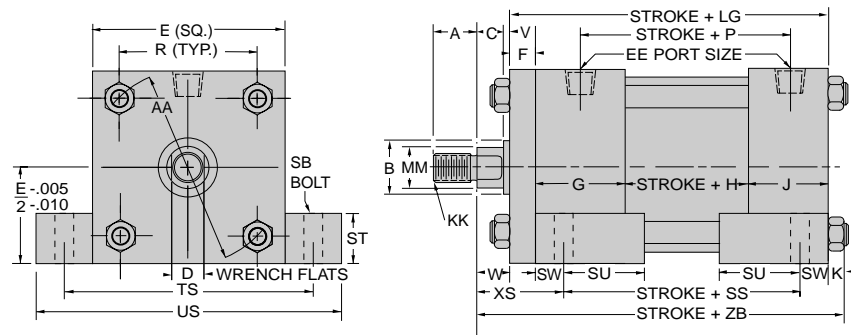

Note: Lugs should be blocked, or a "K" retainer should be mounted on the appropriate end to absorb hydraulic or mechanical shock. Bolts should not carry shear load.

Common Rod End Styles & Dimensions (See page 56 for complete listing of rod end styles.)

Style No. 2-Standard Threaded on Turndown Section

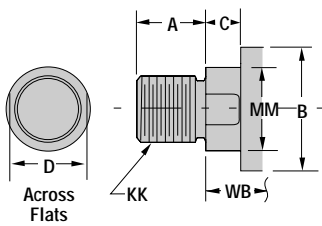

Style No. 4 Short Rod End-Internal Threads

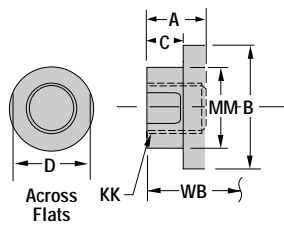

Style No. 6 Studded Rod End

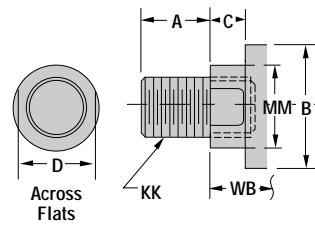

Pressure Limitations For Model *72 Side Lug

Bore		1½	2	2½	3¼	4	5	6	7
Pressure (PSI)	MODERATE	2500	1760	1090	1380	920	880	770	620
	SEVERE	1500	1050	650	820	550	520	460	370

* NOTE: Lugs should be blocked, or a "K" retainer should be mounted on the appropriate end to absorb hydraulic or mechanical shock. Mounting holes are 1/16" larger than bolt sizes (SB) shown.

For overall length on double rod-end cylinders, use common dimension "Stroke plus LD" instead of "Stroke plus SS" shown here and subtract "SW" from each end.

Miller Series A Air Cylinders & Series J Hydraulic Cylinders

Side Lug
1½" - 7" Bore Cylinders

Model 72 Bolted Bushing and Retainer Construction

Bore Size	AA	E	EE	F	G	J	K	R	SB	ST	SU	SW	TS	US
1½	2.02	2	¾-18	¾	1½	1	¼	1.43	¾	½	15/16	¾	2¾	3½
2	2.60	2½	¾-18	¾	1½	1	5/16	1.84	¾	½	15/16	¾	3¼	4
2½	3.10	3	¾-18	¾	1½	1	5/16	2.19	¾	½	15/16	¾	3¾	4½
3¼	3.90	3¾	½-14	5/8	1¾	1¼	¾	2.76	½	¾	1¼	½	4¾	5¾
4	4.70	4½	½-14	5/8	1¾	1¼	¾	3.32	½	¾	1¼	½	5½	6½
5	5.80	5½	½-14	5/8	1¾	1¼	7/16	4.10	¾	1	19/16	11/16	67/8	8¼
6	6.90	6½	¾-14	¾	2	1½	7/16	4.88	¾	1	19/16	11/16	77/8	9¼
7	8.10	7½	¾-14	1	2	1½	9/16	5.73	¾	1	19/16	11/16	87/8	10¼

† LD Dimension is for double rod end models. See page 40.

Stroke Plus

H	P	LB	†LD	LG	SS
1½	2¼	35/8	4½	4	27/8
2	2¼	35/8	4½	4	27/8
2½	2¾	3¾	4¼	4½	3
3¼	25/8	4¼	4¾	47/8	3¼
4	25/8	4¼	4¾	47/8	3¼
5	27/8	4½	5	5½	3½
6	31/8	5	5½	5¾	35/8
7	3¼	5½	55/8	-	3¾

Rod End Dimensions

Bore Size	Rod Dia (MM)	A	B - .001 to -.003	C	D	V	W	AB	KK Styles 2,4&6	RD (Max.)	RT	VB	WB	XS
1½	5/8	¾	1.125	¾	½**	¼	5/8	10-32	7/16-20	1.972	.141	5/8	1	1¾
	1	11/8	1.500	½	7/8**	½	1	—	¾-16	2.472	.313	7/8	1¾	1¾
2	5/8	¾	1.125	¾	½**	—	—	10-32	7/16-20	1.972	.141	5/8	1	1¾
	1	11/8	1.500	½	7/8**	½	1	¼-28	¾-16	2.472	.313	7/8	1¾	1¾
	1¾	15/8	2.000	5/8	11/8	5/8	1¼	—	1-14	2.972	.313	1	15/8	2
2½	5/8	¾	1.125	¾	½**	—	—	10-32	7/16-20	1.972	.141	5/8	1	1¾
	1	11/8	1.500	½	7/8**	—	—	¼-28	¾-16	2.472	.313	7/8	1¾	1¾
	1¾	15/8	2.000	5/8	11/8	5/8	1¼	¼-28	1-14	2.972	.313	1	15/8	2
3¼	5/8	¾	1.125	¾	½**	—	—	10-32	7/16-20	1.972	.141	5/8	1	1¾
	1	11/8	1.500	½	7/8**	—	—	¼-28	¾-16	2.472	.313	7/8	1¾	1¾
	1¾	15/8	2.000	5/8	11/8	—	—	¼-28	1-14	2.972	.313	1	15/8	2½
4	1	11/8	1.500	½	7/8**	—	—	¼-28	¾-16	2.472	.313	7/8	1¾	1¾
	1¾	15/8	2.000	5/8	11/8	—	—	¼-28	1-14	2.972	.313	1	15/8	2½
	2	2¼	2.625	¾	1½	½	1¼	¼-28	1½-12	3.720	.313	1½	2	2½
5	1	11/8	1.500	½	7/8**	—	—	¼-28	¾-16	2.472	.313	7/8	1¾	1¾
	1¾	15/8	2.000	5/8	11/8	—	—	¼-28	1-14	2.972	.313	1	15/8	2½
	1¾	15/8	2.000	5/8	11/8	—	—	¼-28	1-14	2.972	.313	1	15/8	2½
	2	2¼	2.625	¾	1½	—	—	¼-28	1½-12	3.720	.313	1½	2	2½
6	1	11/8	1.500	½	7/8**	—	—	¼-28	¾-16	2.472	.313	7/8	1¾	1¾
	1¾	15/8	2.000	5/8	11/8	—	—	¼-28	1-14	2.972	.313	1	15/8	2½
	1¾	15/8	2.000	5/8	11/8	—	—	¼-28	1-14	2.972	.313	1	15/8	2½
	2	2¼	2.625	¾	1½	—	—	¼-28	1½-12	3.720	.313	1½	2	2½
	2½	3	3.125	1	21/16	—	—	¼-28	17/8-12	4.252	.313	1¼	2¼	25/16
	3	3½	3.750	1	25/8	5/8	15/8	¼-28	2¼-12	4.752	.313	1¼	2¼	25/16
7	1¾	15/8	2.000	5/8	11/8	—	—	¼-28	1-14	2.972	.313	1	15/8	2½
	1¾	15/8	2.000	5/8	11/8	—	—	¼-28	1-14	2.972	.313	1	15/8	2½
	2	2¼	2.625	¾	1½	—	—	¼-28	1½-12	3.720	.313	1½	2	2½
	2½	3	3.125	1	21/16	—	—	¼-28	17/8-12	4.252	.313	1¼	2¼	25/16
	3	3½	3.750	1	25/8	—	—	¼-28	2¼-12	4.752	.313	1¼	2¼	25/16
	3½	3½	4.250	1	3	—	—	¼-28	2½-12	5.252	.313	1¼	2¼	25/16
	4	4	4.750	1	33/8	½	1½	5/16-24	3-12	5.939	.610	1¼	2¼	25/16
	4½	4½	5.250	1	37/8	—	—	5/16-24	3¼-12	6.439	.610	1¼	2¼	25/16
7	5	5	5.750	1	4¼	—	—	5/16-24	3½-12	6.939	.610	1¼	2¼	25/16

** For Style #1 Rod End, 5/8 Rod Dia. — D=7/16". 1" Rod Dia. — D=13/16"

Stroke Plus

ZB
47/8
5¼
415/16
55/16
51/16
57/16
511/16
515/16
6
6¼
6½
65/8
6
6¼
6½
65/8
67/8
65/16
69/16
613/16
615/16
73/16
73/16
71/16
75/16
77/16
711/16
711/16
715/16
715/16
715/16
715/16
715/16
715/16
715/16

Side Lug Mounts

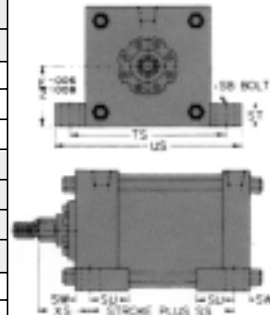

Side Lug
Model 72-B (NFPA MS2)

* NOTE: Lugs should be blocked, or a "K" retainer should be mounted on the appropriate end to absorb hydraulic or mechanical shock. Mounting holes are 1/16" larger than bolt sizes (SB) shown.

For overall length on double rod-end cylinders, use common dimension "Stroke plus LD" instead of "Stroke plus SS" shown here and subtract "SW" from each end.

Miller Series A Air Cylinders & Series J Hydraulic Cylinders

Centerline Lug
1 1/2" - 7" Bore Cylinders

Model 73-B (NFPA MS3)
Bolted Bushing
Centerline Lug

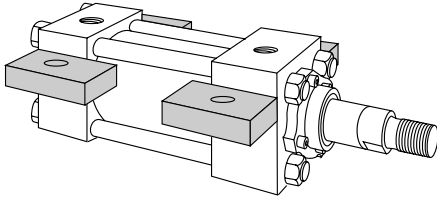

Mounting Dimensions

(See tables on opposite page)

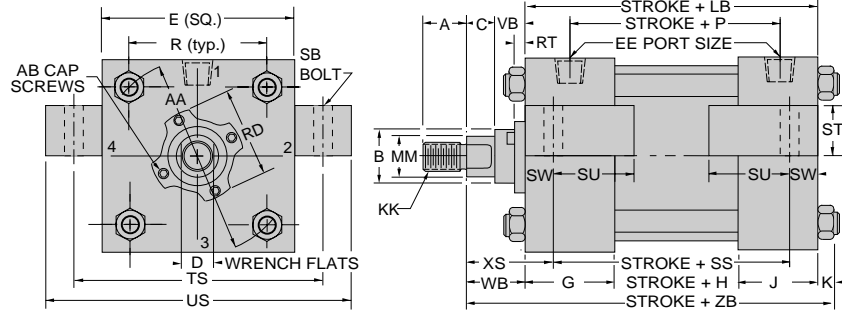

Note: Lugs should be blocked or pinned on the appropriate end to absorb hydraulic or mechanical shock. Bolts should not carry shear load.

Model 73-R (NFPA MS3)
Square Retainer Held Bushing
Centerline Lug

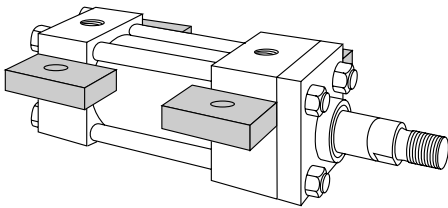

Mounting Dimensions

(See tables on opposite page)

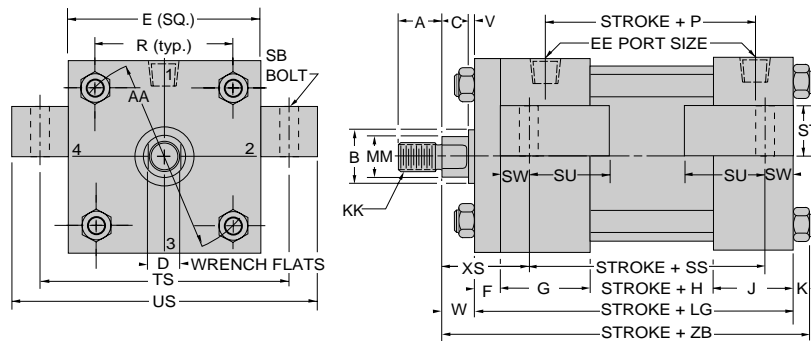

Note: Lugs should be blocked or pinned on the appropriate end to absorb hydraulic or mechanical shock. Bolts should not carry shear load.

Common Rod End Styles & Dimensions (See page 56 for complete listing of rod end styles.)

Style No. 2-Standard
Threaded on Turndown Section

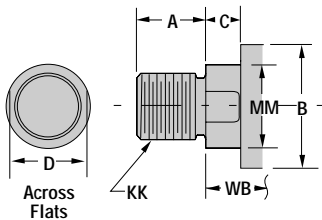

Style No. 4
Short Rod End-Internal Threads

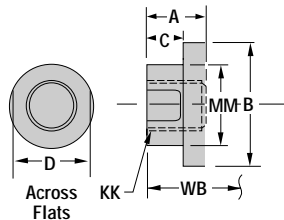

Style No. 6
Studded Rod End

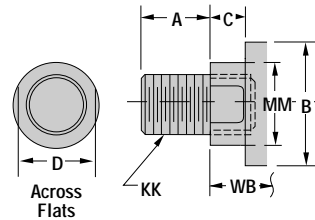

Miller Series A Air Cylinders & Series J Hydraulic Cylinders

Centerline Lug
1 1/2" - 7" Bore Cylinders

Model 73 Bolted Bushing and Retainer Construction

Bore Size	AA	E	EE	F	G	J	K	R	SB	ST	SU	SW	TS	US
1 1/2	2.02	2	3/8-18	3/8	1 1/2	1	1/4	1.43	3/8	1/2	1 5/16	3/8	2 3/4	3 1/2
2	2.60	2 1/2	3/8-18	3/8	1 1/2	1	5/16	1.84	3/8	1/2	1 5/16	3/8	3 1/4	4
2 1/2	3.10	3	3/8-18	3/8	1 1/2	1	5/16	2.19	3/8	1/2	1 5/16	3/8	3 3/4	4 1/2
3 1/4	3.90	3 3/4	1/2-14	5/8	1 3/4	1 1/4	3/8	2.76	1/2	3/4	1 1/4	1/2	4 3/4	5 3/4
4	4.70	4 1/2	1/2-14	5/8	1 3/4	1 1/4	3/8	3.32	1/2	3/4	1 1/4	1/2	5 1/2	6 1/2
5	5.80	5 1/2	1/2-14	5/8	1 3/4	1 1/4	7/16	4.10	3/4	1	1 9/16	1 1/16	6 7/8	8 1/4
6	6.90	6 1/2	3/4-14	3/4	2	1 1/2	7/16	4.88	3/4	1	1 9/16	1 1/16	7 7/8	9 1/4
7	8.10	7 1/2	3/4-14	1	2	1 1/2	9/16	5.73	3/4	1	1 9/16	1 1/16	8 7/8	10 1/4

† LD Dimension is for double rod end models. See page 40.

Stroke Plus

H	P	LB	†LD	LG	SS
1 1/8	2 1/4	3 5/8	4 1/8	4	2 7/8
1 1/8	2 1/4	3 5/8	4 1/8	4	2 7/8
1 1/4	2 3/8	3 3/4	4 1/4	4 1/8	3
1 1/4	2 5/8	4 1/4	4 3/4	4 7/8	3 1/4
1 1/4	2 5/8	4 1/4	4 3/4	4 7/8	3 1/4
1 1/2	2 7/8	4 1/2	5	5 1/8	3 1/8
1 1/2	3 1/8	5	5 1/2	5 3/4	3 5/8
1 5/8	3 1/4	5 1/8	5 5/8	-	3 3/4

Rod End Dimensions

Bore Size	Rod Dia (MM)	A	B -.001 to -.003	C	D	V	W	AB	KK Styles 2,4&6	RD (Max.)	RT	VB	WB	XS
1 1/2	5/8	3/4	1.125	3/8	1/2**	1/4	5/8	10-32	7/16-20	1.972	.141	5/8	1	1 3/8
	1	1 1/8	1.500	1/2	7/8**	1/2	1	-	3/4-16	2.472	.313	7/8	1 3/8	1 3/4
2	5/8	3/4	1.125	3/8	1/2**	-	-	10-32	7/16-20	1.972	.141	5/8	1	1 3/8
	1	1 1/8	1.500	1/2	7/8**	1/2	1	1/4-28	3/4-16	2.472	.313	7/8	1 3/8	1 3/4
	1 3/8	1 5/8	2.000	5/8	1 1/8	5/8	1 1/4	-	1-14	2.972	.313	1	1 5/8	2
2 1/2	5/8	3/4	1.125	3/8	1/2**	-	-	10-32	7/16-20	1.972	.141	5/8	1	1 3/8
	1	1 1/8	1.500	1/2	7/8**	-	-	1/4-28	3/4-16	2.472	.313	7/8	1 3/8	1 3/4
	1 3/8	1 5/8	2.000	5/8	1 1/8	5/8	1 1/4	1/4-28	1-14	2.972	.313	1	1 5/8	2
3 1/4	1 3/8	2	2.375	3/4	1 1/2	3/4	1 1/2	-	1 1/4-12	3.470	.313	1 1/8	1 7/8	2 1/4
	1	1 1/8	1.500	1/2	7/8**	-	-	1/4-28	3/4-16	2.472	.313	7/8	1 3/8	1 7/8
	1 3/8	1 5/8	2.000	5/8	1 1/8	-	-	1/4-28	1-14	2.972	.313	1	1 5/8	2 1/8
4	1 3/4	2	2.375	3/4	1 1/2	1/2	1 1/4	1/4-28	1 1/4-12	3.470	.313	1 1/8	1 7/8	2 3/8
	2	2 1/4	2.625	7/8	1 11/16	1/2	1 3/8	1/4-28	1 1/2-12	3.720	.313	1 1/8	2	2 1/2
	1	1 1/8	1.500	1/2	7/8**	-	-	1/4-28	3/4-16	2.472	.313	7/8	1 3/8	1 7/8
5	1 3/8	1 5/8	2.000	5/8	1 1/8	-	-	1/4-28	1-14	2.972	.313	1	1 5/8	2 1/8
	1 3/4	2	2.375	3/4	1 1/2	-	-	1/4-28	1 1/4-12	3.470	.313	1 1/8	1 7/8	2 3/8
	2	2 1/4	2.625	7/8	1 11/16	-	-	1/4-28	1 1/2-12	3.720	.313	1 1/8	2	2 1/2
	2 1/2	3	3.125	1	2 1/16	-	-	1/4-28	1 7/8-12	4.252	.313	1 1/4	2 1/4	2 5/8
	3	3 1/2	3.750	1	2 5/8	5/8	1 5/8	1/4-28	2 1/4-12	4.752	.313	1 1/4	2 1/4	2 5/8
6	3 1/2	3 1/2	4.250	1	3	5/8	1 5/8	1/4-28	2 1/2-12	5.252	.313	1 1/4	2 1/4	2 5/8
	1 3/8	1 5/8	2.000	5/8	1 1/8	-	-	1/4-28	1-14	2.972	.313	1	1 5/8	2 1/8
	1 3/4	2	2.375	3/4	1 1/2	-	-	1/4-28	1 1/4-12	3.470	.313	1 1/8	1 7/8	2 1/8
	2	2 1/4	2.625	7/8	1 11/16	-	-	1/4-28	1 1/2-12	3.720	.313	1 1/8	2	2 1 1/16
	2 1/2	3	3.125	1	2 1/16	-	-	1/4-28	1 7/8-12	4.252	.313	1 1/4	2 1/4	2 1 5/16
7	3	3 1/2	3.750	1	2 5/8	-	-	1/4-28	2 1/4-12	4.752	.313	1 1/4	2 1/4	2 1 5/16
	3 1/2	3 1/2	4.250	1	3	-	-	1/4-28	2 1/2-12	5.252	.313	1 1/4	2 1/4	2 1 5/16
	4	4	4.750	1	3 3/8	1/2	1 1/2	5/16-24	3-12	5.939	.610	1 1/4	2 1/4	2 1 5/16
	1 3/8	1 5/8	2.000	5/8	1 1/8	-	-	1/4-28	1-14	2.972	.313	1	1 5/8	2 1/8
	1 3/4	2	2.375	3/4	1 1/2	-	-	1/4-28	1 1/4-12	3.470	.313	1 1/8	1 7/8	2 1/8
	2	2 1/4	2.625	7/8	1 11/16	-	-	1/4-28	1 1/2-12	3.720	.313	1 1/8	2	2 1 1/16
	2 1/2	3	3.125	1	2 1/16	-	-	1/4-28	1 7/8-12	4.252	.313	1 1/4	2 1/4	2 1 5/16
	3	3 1/2	3.750	1	2 5/8	-	-	1/4-28	2 1/4-12	4.752	.313	1 1/4	2 1/4	2 1 5/16
3 1/2	3 1/2	4.250	1	3	-	-	1/4-28	2 1/2-12	5.252	.313	1 1/4	2 1/4	2 1 5/16	
4	4	4.750	1	3 3/8	-	-	5/16-24	3-12	5.939	.610	1 1/4	2 1/4	2 1 5/16	
4 1/2	4 1/2	5.250	1	3 7/8	-	-	5/16-24	3 1/4-12	6.439	.610	1 1/4	2 1/4	2 1 5/16	
5	5	5.750	1	4 1/4	-	-	5/16-24	3 1/2-12	6.939	.610	1 1/4	2 1/4	2 1 5/16	

** For Style #1 Rod End, 5/8 Rod Dia. — D=7/16". 1" Rod Dia. — D=1 1/16"

Stroke Plus

ZB
4 7/8
5 1/4
4 15/16
5 5/16
5 9/16
5 1/16
5 7/16
5 1 1/16
5 15/16
6
6 1/4
6 1/2
6 5/8
6
6 1/4
6 1/2
6 5/8
6 7/8
6 5/16
6 9/16
6 13/16
6 15/16
7 3/16
7 3/16
7 1/16
7 5/16
7 7/16
7 1 1/16
7 1 1/16
7 1 1/16
7 1 1/16
7 1 1/16
7 5/16
7 9/16
7 1 1/16
7 1 1/16
7 1 1/16
7 1 1/16
7 1 1/16
7 1 1/16
7 1 1/16

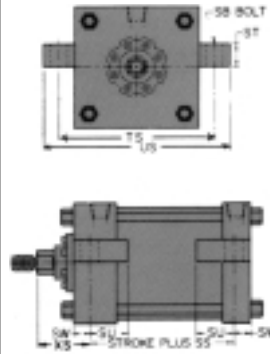

Centerline Lug
Model 73-B (NPPA MS3)

* NOTE: Lugs should be blocked, or a "K" retainer should be mounted on the appropriate end to absorb hydraulic or mechanical shock. Mounting holes are 1/16" larger than bolt sizes (SB) shown.

For overall length on double rod-end cylinders, use common dimension "Stroke plus LD" instead of "Stroke plus SS" shown here and subtract "SW" from each end.

Miller Series A Air Cylinders & Series J Hydraulic Cylinders

Side Tapped
1½" - 7" Bore Cylinders

Model 74-B (NFPA MS4) Bolted Bushing Side Tapped

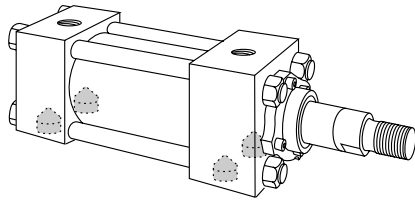

Note: A "K" retainer should be mounted on the appropriate end to absorb hydraulic or mechanical shock. Bolts should not carry shear load.

Mounting Dimensions (See tables on opposite page)

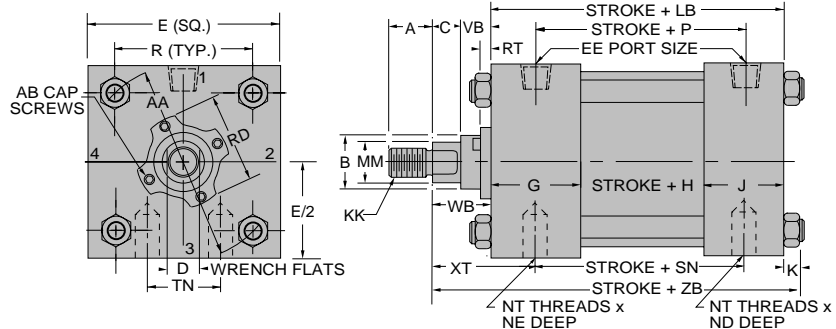

Model 74-R (NFPA MS4) Square Retainer Held Bushing Side Tapped

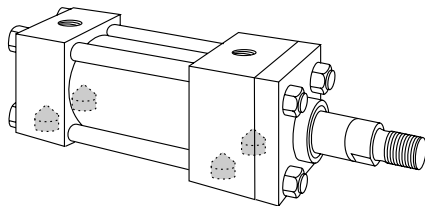

Note: A "K" retainer should be mounted on the appropriate end to absorb hydraulic or mechanical shock. Bolts should not carry shear load.

Mounting Dimensions (See tables on opposite page)

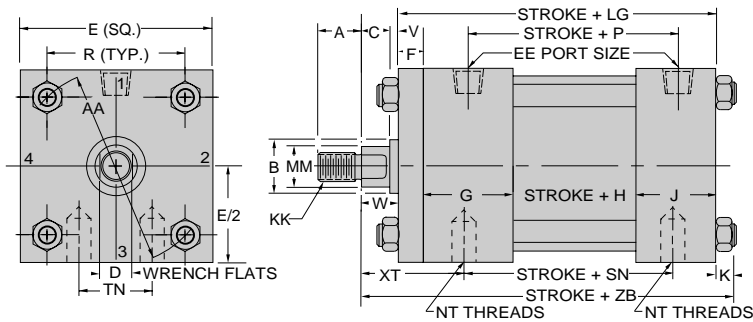

Common Rod End Styles & Dimensions (See page 56 for complete listing of rod end styles.)

Style No. 2-Standard
Threaded on Turndown Section

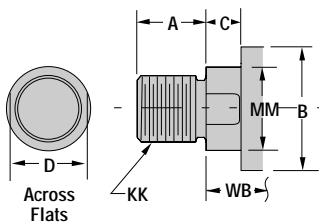

Style No. 4
Short Rod End-Internal Threads

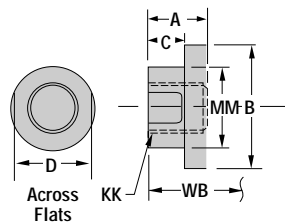

Style No. 6
Studded Rod End

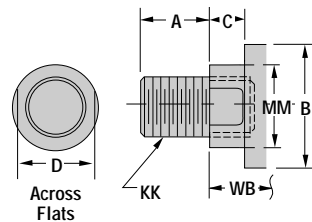

Pressure Limitations For Model *74 Side Tapped

BORE	PRESSURE LIMITATIONS	
	MODERATE PSI	SEVERE PSI
1½	2100	1260
2	2050	1260
2½	1150	690
3¼	1750	1050
4	900	540
5	800	480
6	800	480
7	500	300

* Note: A "K" retainer should be mounted on the appropriate end to absorb hydraulic or mechanical shock. Mounting holes are 1/16" larger than bolt sizes (SB) shown.

Miller Series A Air Cylinders & Series J Hydraulic Cylinders

Side Tapped
1 1/2" – 7" Bore Cylinders

Model 74 Bolted Bushing and Retainer Construction

Stroke Plus

Bore Size	AA	E	EE	F	G	J	K	R	NT	TN
1 1/2	2.02	2	3/8-18	3/8	1 1/2	1	1/4	1.43	1/4-20	5/8
2	2.60	2 1/2	3/8-18	3/8	1 1/2	1	5/16	1.84	5/8-18	7/8
2 1/2	3.10	3	3/8-18	3/8	1 1/2	1	5/16	2.19	3/8-16	1 1/4
3 1/4	3.90	3 3/4	1/2-14	5/8	1 3/4	1 1/4	3/8	2.76	1/2-13	1 1/2
4	4.70	4 1/2	1/2-14	5/8	1 3/4	1 1/4	3/8	3.32	1/2-13	2 1/16
5	5.80	5 1/2	1/2-14	5/8	1 3/4	1 1/4	7/16	4.10	5/8-11	2 11/16
6	6.90	6 1/2	3/4-14	3/4	2	1 1/2	7/16	4.88	3/4-10	3 1/4
7	8.10	7 1/2	3/4-14	1	2	1 1/2	9/16	5.73	3/4-10	3 7/8

H	P	LB	LD	LG	SN
1 1/8	2 1/4	3 5/8	4 1/8	4	2 1/4
1 1/8	2 1/4	3 5/8	4 1/8	4	2 1/4
1 1/4	2 3/8	3 3/4	4 1/4	4 1/8	2 3/8
1 1/4	2 5/8	4 1/4	4 3/4	4 7/8	2 5/8
1 1/4	2 5/8	4 1/4	4 3/4	4 7/8	2 5/8
1 1/2	2 7/8	4 1/2	5	5 1/8	2 7/8
1 1/2	3 1/8	5	5 1/2	5 3/4	3 1/8
1 5/8	3 1/4	5 1/8	5 5/8	-	3 1/4

† LD Dimension is for double rod end models. See page 40.

Rod End Dimensions

Stroke Plus

Bore Size	Rod Dia (MM)	A	B - .001 to -.003	C	D	V	W	AB	KK Styles 2,4&6	RD (Max.)	RT	VB	WB	XT	ZB
1 1/2	5/8	3/4	1.125	3/8	1/2**	1/4	5/8	10-32	7/16-20	1.972	.141	5/8	1	1 15/16	4 7/8
	1	1 1/8	1.500	1/2	7/8**	1/2	1	—	3/4-16	2.472	.313	7/8	1 3/8	N/A†	5 1/4
2	5/8	3/4	1.125	3/8	1/2**	—	—	10-32	7/16-20	1.972	.141	5/8	1	1 15/16	4 15/16
	1	1 1/8	1.500	1/2	7/8**	1/2	1	1/4-28	3/4-16	2.472	.313	7/8	1 3/8	N/A†	5 5/16
	1 3/8	1 5/8	2.000	5/8	1 1/8	5/8	1 1/4	—	1-14	2.972	.313	1	1 5/8	N/A†	5 9/16
2 1/2	5/8	3/4	1.125	3/8	1/2**	—	—	10-32	7/16-20	1.972	.141	5/8	1	1 15/16	5 1/16
	1	1 1/8	1.500	1/2	7/8**	—	—	1/4-28	3/4-16	2.472	.313	7/8	1 3/8	2 5/16	5 7/16
	1 3/8	1 5/8	2.000	5/8	1 1/8	5/8	1 1/4	1/4-28	1-14	2.972	.313	1	1 5/8	N/A†	5 11/16
3 1/4	1	1 1/8	1.500	1/2	7/8**	—	—	1/4-28	3/4-16	2.472	.313	7/8	1 3/8	2 7/16	6
	1 3/8	1 5/8	2.000	5/8	1 1/8	—	—	1/4-28	1-14	2.972	.313	1	1 5/8	2 11/16	6 1/4
	1 3/4	2	2.375	3/4	1 1/2	1/2	1 1/4	1/4-28	1 1/4-12	3.470	.313	1 1/8	1 7/8	N/A†	6 1/2
4	2	2 1/4	2.625	7/8	1 11/16	1/2	1 3/8	1/4-28	1 1/2-12	3.720	.313	1 1/8	2	N/A†	6 5/8
	1	1 1/8	1.500	1/2	7/8**	—	—	1/4-28	3/4-16	2.472	.313	7/8	1 3/8	2 7/16	6
	1 3/8	1 5/8	2.000	5/8	1 1/8	—	—	1/4-28	1-14	2.972	.313	1	1 5/8	2 11/16	6 1/4
	1 3/4	2	2.375	3/4	1 1/2	—	—	1/4-28	1 1/4-12	3.470	.313	1 1/8	1 7/8	2 15/16	6 1/2
5	2	2 1/4	2.625	7/8	1 11/16	—	—	1/4-28	1 1/2-12	3.720	.313	1 1/8	2	3 1/16	6 5/8
	2 1/2	3	3.125	1	2 1/16	—	—	1/4-28	1 7/8-12	4.252	.313	1 1/4	2 1/4	3 5/16†	6 7/8
	3	3 1/2	3.750	1	2 5/8	5/8	1 5/8	1/4-28	2 1/4-12	4.752	.313	1 1/4	2 1/4	3 5/16†	7 3/16
	3 1/2	3 1/2	4.250	1	3	5/8	1 5/8	1/4-28	2 1/2-12	5.252	.313	1 1/4	2 1/4	N/A†	7 3/16
	1	1 1/8	1.500	1/2	7/8**	—	—	1/4-28	3/4-16	2.472	.313	7/8	1 3/8	2 7/16	6 5/16
	1 3/8	1 5/8	2.000	5/8	1 1/8	—	—	1/4-28	1-14	2.972	.313	1	1 5/8	2 11/16	6 9/16
6	1 3/4	2	2.375	3/4	1 1/2	—	—	1/4-28	1 1/4-12	3.470	.313	1 1/8	1 7/8	2 15/16	6 13/16
	2	2 1/4	2.625	7/8	1 11/16	—	—	1/4-28	1 1/2-12	3.720	.313	1 1/8	2	3 1/16	6 15/16
	2 1/2	3	3.125	1	2 1/16	—	—	1/4-28	1 7/8-12	4.252	.313	1 1/4	2 1/4	3 7/16†	7 1/16
	3	3 1/2	3.750	1	2 5/8	—	—	1/4-28	2 1/4-12	4.752	.313	1 1/4	2 1/4	3 7/16†	7 11/16
	3 1/2	3 1/2	4.250	1	3	—	—	1/4-28	2 1/2-12	5.252	.313	1 1/4	2 1/4	3 7/16†	7 11/16
	4	4	4.750	1	3 3/8	1/2	1 1/2	5/16-24	3-12	5.939	.610	1 1/4	2 1/4	N/A†	7 11/16
7	1 3/8	1 5/8	2.000	5/8	1 1/8	—	—	1/4-28	1-14	2.972	.313	1	1 5/8	2 13/16*	7 5/16
	1 3/4	2	2.375	3/4	1 1/2	—	—	1/4-28	1 1/4-12	3.470	.313	1 1/8	1 7/8	3 1/16	7 9/16
	2	2 1/4	2.625	7/8	1 11/16	—	—	1/4-28	1 1/2-12	3.720	.313	1 1/8	2	3 3/16	7 11/16
	2 1/2	3	3.125	1	2 1/16	—	—	1/4-28	1 7/8-12	4.252	.313	1 1/4	2 1/4	3 7/16†	7 15/16
	3	3 1/2	3.750	1	2 5/8	—	—	1/4-28	2 1/4-12	4.752	.313	1 1/4	2 1/4	3 7/16†	7 15/16
	3 1/2	3 1/2	4.250	1	3	—	—	1/4-28	2 1/2-12	5.252	.313	1 1/4	2 1/4	3 7/16†	7 15/16
	4	4	4.750	1	3 3/8	—	—	5/16-24	3-12	5.939	.610	1 1/4	2 1/4	3 7/16†	7 15/16
	4 1/2	4 1/2	5.250	1	3 7/8	—	—	5/16-24	3 1/4-12	6.439	.610	1 1/4	2 1/4	3 7/16†	7 15/16
5	5	5.750	1	4 1/4	—	—	5/16-24	3 1/2-12	6.939	.610	1 1/4	2 1/4	3 7/16†	7 15/16	

** For Style #1 Rod End, 5/8 Rod Dia. — D=7/16". 1" Rod Dia. — D=13/16"

† Note: Certain oversized rods have reduced pressure ratings. Consult Miller Fluid Power's Application Engineer and File No. 7673 for pressure ratings before specifying oversized rods.

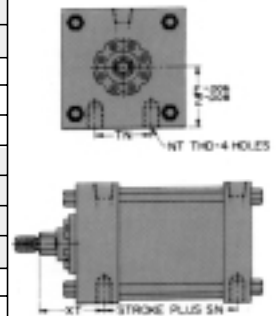

SIDE TAPPED
Model 74-B (NFPA MS4)

* Note: A "K" retainer should be mounted on the appropriate end to absorb hydraulic or mechanical shock. Mounting holes are 1/16" larger than bolt sizes (SB) shown.

Miller Series A Air Cylinders & Series J Hydraulic Cylinders

End Lug
1½" - 7" Bore Cylinders

Model 77-B (NFPA MS7) Bolted Bushing End Lug

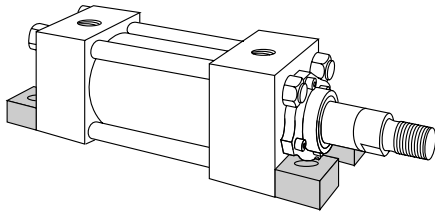

Note: Mounting bolts should not carry shear load. Lugs should be blocked or a "K" retainer should be mounted on the appropriate end to absorb hydraulic or mechanical shock.

Mounting Dimensions (See tables on opposite page)

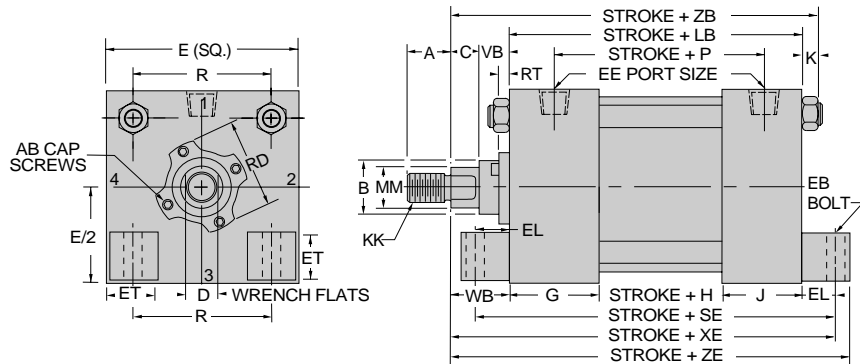

Model 77-R (NFPA MS7) Square Retainer Held Bushing End Lug

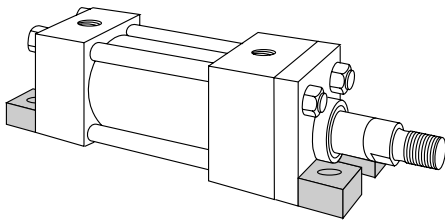

Note: Mounting bolts should not carry shear load. Lugs should be blocked or a "K" retainer should be mounted on the appropriate end to absorb hydraulic or mechanical shock.

Mounting Dimensions (See tables on opposite page)

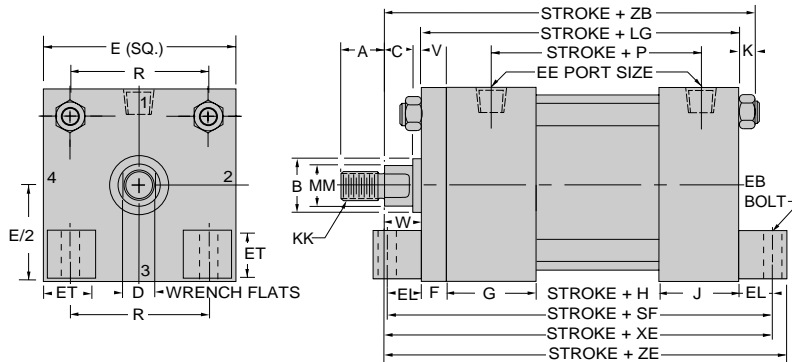

Common Rod End Styles & Dimensions (See page 56 for complete listing of rod end styles.)

Style No. 2-Standard
Threaded on Turndown Section

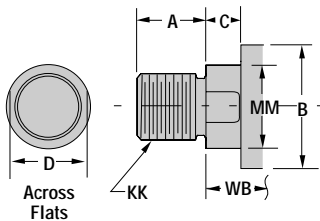

Style No. 4
Short Rod End-Internal Threads

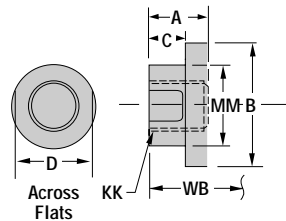

Style No. 6
Studded Rod End

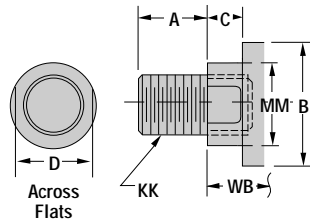

Pressure Limitations For Model *77 End Lug

BORE	PRESSURE LIMITATIONS	
	MODERATE PSI	SEVERE PSI
1½	2100	1260
2	2050	1260
2½	1150	690
3¼	1750	1050
4	900	540
5	800	500
6	800	500
7	500	300

* Note: A "K" retainer should be mounted on the appropriate end to absorb hydraulic or mechanical shock. Mounting holes are 1/16" larger than bolt sizes (EB) shown. For overall length on double rod-end cylinders, use common dimension "Stroke plus LD" instead of figures shown here as "ZE", "XE" and "SE," and add mounting lug dimensions.

Miller Series A Air Cylinders & Series J Hydraulic Cylinders

End Lug
1 1/2" - 7" Bore Cylinders

Model 77 Bolted Bushing and Retainer Construction

Stroke Plus

Bore Size	E	EE	F	G	J	K	R	EB	EL	ET
1 1/2	2	3/8-18	3/8	1 1/2	1	1/4	1.43	1/4	3/4	1/2
2	2 1/2	3/8-18	3/8	1 1/2	1	5/16	1.84	5/16	15/16	19/32
2 1/2	3	3/8-18	3/8	1 1/2	1	5/16	2.19	5/16	1 1/16	3/4
3 1/4	3 3/4	1/2-14	5/8	1 3/4	1 1/4	3/8	2.76	3/8	7/8	29/32
4	4 1/2	1/2-14	5/8	1 3/4	1 1/4	3/8	3.32	3/8	1	1 1/8
5	5 1/2	1/2-14	5/8	1 3/4	1 1/4	7/16	4.10	1/2	1 1/16	1 11/32
6	6 1/2	3/4-14	3/4	2	1 1/2	7/16	4.88	1/2	1	1 9/16
7	7 1/2	3/4-14	1	2	1 1/2	9/16	5.73	5/8	1 1/8	1 11/16

H	P	LB	LD	LG	SE	SF
1 1/8	2 1/4	3 5/8	4 1/8	4	5 1/8	5 1/2
1 1/8	2 1/4	3 5/8	4 1/8	4	5 1/2	5 7/8
1 1/4	2 3/8	3 3/4	4 1/4	4 1/8	5 7/8	6 1/4
1 1/4	2 5/8	4 1/4	4 3/4	4 7/8	6	6 5/8
1 1/4	2 5/8	4 1/4	4 3/4	4 7/8	6 1/4	6 7/8
1 1/2	2 7/8	4 1/2	5	5 1/8	6 5/8	7 1/4
1 1/2	3 1/8	5	5 1/2	5 3/4	7	7 3/4
1 5/8	3 1/4	5 1/8	5 5/8	-	7 3/8	8 3/8

† LD Dimension is for double rod end models. See page 40.

Rod End Dimensions

Stroke Plus

Bore Size	Rod Dia (MM)	A	B -.001 to -.003	C	D	V	W	AB	KK Styles 2,4&6	RD (Max.)	RT	VB	WB	XE	ZE	ZB
1 1/2	5/8	3/4	1.125	3/8	1/2**	1/4	5/8	10-32	7/16-20	1.972	.141	5/8	1	5 3/8	5 5/8	4 7/8
	1	1 1/8	1.500	1/2	7/8**	1/2	1	-	3/4-16	2.472	.313	7/8	1 3/8	5 3/4	6	5 1/4
2	5/8	3/4	1.125	3/8	1/2**	-	-	10-32	7/16-20	1.972	.141	5/8	1	5 9/16	5 7/8	4 15/16
	1	1 1/8	1.500	1/2	7/8**	1/2	1	1/4-28	3/4-16	2.472	.313	7/8	1 3/8	5 15/16	6 1/4	5 5/16
2 1/2	1 3/8	1 5/8	2.000	5/8	1 1/8	5/8	1 1/4	-	1-14	2.972	.313	1	1 5/8	6 3/16	6 1/2	5 9/16
	5/8	3/4	1.125	3/8	1/2**	-	-	10-32	7/16-20	1.972	.141	5/8	1	5 13/16	6 1/8	5 1/16
3 1/4	1	1 1/8	1.500	1/2	7/8**	-	-	1/4-28	3/4-16	2.472	.313	7/8	1 3/8	6 3/16	6 1/2	5 1/16
	1 3/8	1 5/8	2.000	5/8	1 1/8	5/8	1 1/4	1/4-28	1-14	2.972	.313	1	1 5/8	6 7/16	6 3/4	5 1 1/16
4	1 3/4	2	2.375	3/4	1 1/2	3/4	1 1/2	-	1 1/4-12	3.470	.313	1 1/8	1 7/8	6 11/16	7	5 15/16
	1	1 1/8	1.500	1/2	7/8**	-	-	1/4-28	3/4-16	2.472	.313	7/8	1 3/8	6 1/2	6 7/8	6
5	1 3/8	1 5/8	2.000	5/8	1 1/8	-	-	1/4-28	1-14	2.972	.313	1	1 5/8	6 3/4	7 1/8	6 1/4
	1 3/4	2	2.375	3/4	1 1/2	1/2	1 1/4	1/4-28	1 1/4-12	3.470	.313	1 1/8	1 7/8	7	7 3/8	6 1/2
6	2	2 1/4	2.625	7/8	1 1/2	1/2	1 3/8	1/4-28	1 1/2-12	3.720	.313	1 1/8	2	7 1/8	7 1/2	6 5/8
	1	1 1/8	1.500	1/2	7/8**	-	-	1/4-28	3/4-16	2.472	.313	7/8	1 3/8	6 5/8	7	6
7	1 3/8	1 5/8	2.000	5/8	1 1/8	-	-	1/4-28	1-14	2.972	.313	1	1 5/8	6 7/8	7 1/4	6 1/4
	1 3/4	2	2.375	3/4	1 1/2	-	-	1/4-28	1 1/4-12	3.470	.313	1 1/8	1 7/8	7 1/8	7 1/2	6 1/2
8	2	2 1/4	2.625	7/8	1 1/2	-	-	1/4-28	1 1/4-12	3.470	.313	1 1/8	1 7/8	7 1/8	7 1/2	6 1/2
	2 1/2	3	3.125	1	2 1/16	-	-	1/4-28	1 7/8-12	4.252	.313	1 1/4	2 1/4	7 1/2	7 7/8	6 7/8
9	3	3 1/2	3.750	1	2 5/8	-	-	1/4-28	2 1/4-12	4.752	.313	1 1/4	2 1/4	7 5/8	8	6 5/8
	3 1/2	3 1/2	4.250	1	3	-	-	1/4-28	2 1/2-12	5.252	.313	1 1/4	2 1/4	7 7/8	8 1/8	6 7/8
10	4	4	4.750	1	3 3/8	1/2	1 1/2	5/16-24	3-12	5.939	.610	1 1/4	2 1/4	8 1/16	8 1/2	6 7/8
	4 1/2	4 1/2	5.250	1	3 7/8	-	-	5/16-24	3 1/4-12	6.439	.610	1 1/4	2 1/4	8 1/4	8 3/4	6 7/8
11	5	5	5.750	1	4 1/4	-	-	5/16-24	3 1/2-12	6.939	.610	1 1/4	2 1/4	8 1/2	8 3/4	6 7/8
	5 1/8	5 1/8	6.250	1	4 3/4	-	-	5/16-24	3 3/4-12	7.439	.610	1 1/4	2 1/4	8 3/4	8 3/4	6 7/8

** For Style #1 Rod End, 5/8 Rod Dia. — D=7/16". 1" Rod Dia. — D=13/16"

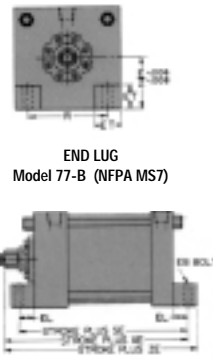

* Note: A "K" retainer should be mounted on the appropriate end to absorb hydraulic or mechanical shock. Mounting holes are 1/16" larger than bolt sizes (EB) shown. For overall length on double rod-end cylinders, use common dimension "Stroke plus LD" instead of figures shown here as "ZE", "XE" and "SE", and add mounting lug dimensions.

Miller Series A Air Cylinders & Series J Hydraulic Cylinders

Trunnion/Head End
1½" – 7" Bore Cylinders

Model 81-B (NFPA MT1) Bolted Bushing Trunnion Head End

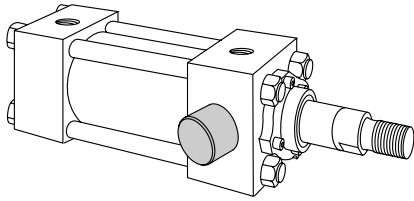

Mounting Dimensions (See tables on opposite page)

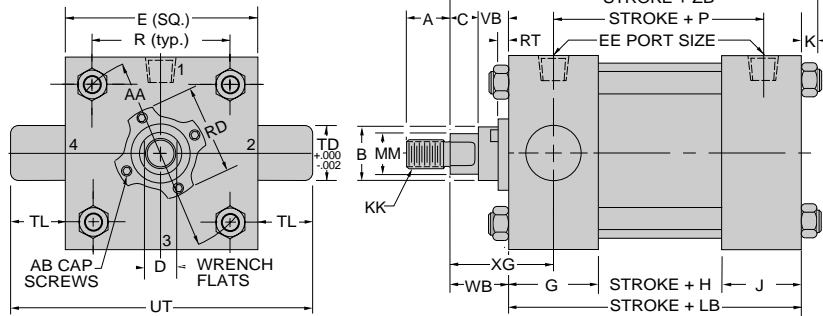

Note: Hard chrome-plated pins designed for shear, (not bending) loads.

Model 81-R (NFPA MT1) Rectangular Retainer Trunnion Head End

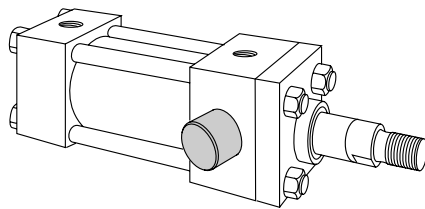

Mounting Dimensions (See tables on opposite page)

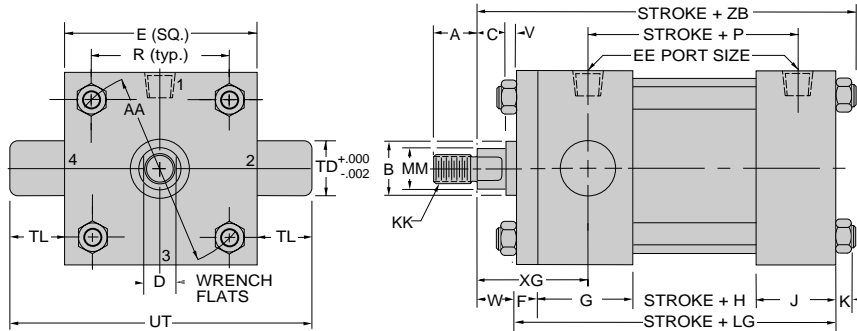

Note: Hard chrome-plated pins designed for shear, (not bending) loads.

Common Rod End Styles & Dimensions (See page 56 for complete listing of rod end styles.)

Style No. 2-Standard
Threaded on Turndown Section

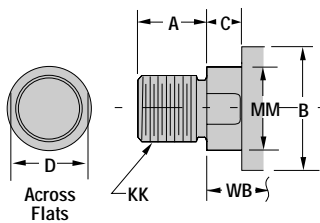

Style No. 4
Short Rod End-Internal Threads

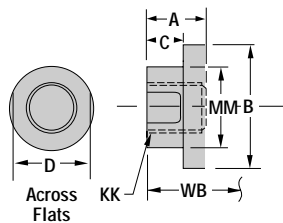

Style No. 6
Studded Rod End

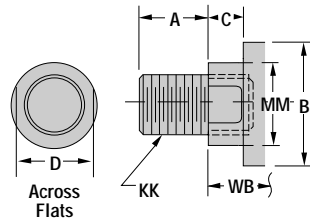

Pressure Limitations for Model 81-82 Trunnion Mounts

BORE	PRESSURE LIMITATIONS	
	MODERATE	SEVERE
	PSI	PSI
1½	2500	1500
2	2500	1500
2½	1500	1000
3¼	1770	1060
4	1170	700
5	750	450
6	1030	610
7	750	450

Note: Pins are designed for shear, (not bending) loads.

* Note: Minimum "XI" dimension values shown apply only to the standard rod diameter. When oversized rods are used, minimum "XI" dimensions are increased by the difference between the "WB" dimension for the oversized rod and the "WB" dimension for the standard rod diameter.

** Note: Consult Miller Fluid Power's Engineering Department for shorter stroke requirements.

Miller Series A Air Cylinders & Series J Hydraulic Cylinders

Trunnion/Head End
1 1/2" – 7" Bore Cylinders

Model 81 Bolted Bushing and Retainer Construction

Bore Size	AA	E	EE	F	G	J	K	R	TD	TL	UT
1 1/2	2.02	2	3/8-18	3/8	1 1/2	1	1/4	1.43	1	1	4
2	2.60	2 1/2	3/8-18	3/8	1 1/2	1	5/16	1.84	1	1	4 1/2
2 1/2	3.10	3	3/8-18	3/8	1 1/2	1	5/16	2.19	1	1	5
3 1/4	3.90	3 3/4	1/2-14	5/8	1 3/4	1 1/4	3/8	2.76	1	1	5 3/4
4	4.70	4 1/2	1/2-14	5/8	1 3/4	1 1/4	3/8	3.32	1	1	6 1/2
5	5.80	5 1/2	1/2-14	5/8	1 3/4	1 1/4	7/16	4.10	1	1	7 1/2
6	6.90	6 1/2	3/4-14	3/4	2	1 1/2	7/16	4.88	1 3/8	1 3/8	9 1/4
7	8.10	7 1/2	3/4-14	1	2	1 1/2	9/16	5.73	1 3/8	1 3/8	10 1/4

† LD Dimension is for double rod end models. See page 40.

Stroke Plus

H	P	LB	†LD	LG
1 1/8	2 1/4	3 5/8	4 1/8	4
1 1/8	2 1/4	3 5/8	4 1/8	4
1 1/4	2 3/8	3 3/4	4 1/4	4 1/8
1 1/4	2 5/8	4 1/4	4 3/4	4 7/8
1 1/4	2 5/8	4 1/4	4 3/4	4 7/8
1 1/2	2 7/8	4 1/2	5	5 1/8
1 1/2	3 1/8	5	5 1/2	5 3/4
1 5/8	3 1/4	5 1/8	5 5/8	-

Rod End Dimensions

Bore Size	Rod Dia (MM)	A	B -.001 to -.003	C	D	V	W	AB	KK Styles 2,4&6	RD (Max.)	RT	VB	WB	XG	ZB
1 1/2	5/8	3/4	1.125	3/8	1/2**	1/4	5/8	10-32	7/16-20	1.972	.141	5/8	1	1 3/4	4 7/8
	1	1 1/8	1.500	1/2	7/8**	1/2	1	—	3/4-16	2.472	.313	7/8	1 3/8	2 1/8	5 1/4
2	5/8	3/4	1.125	3/8	1/2**	—	—	10-32	7/16-20	1.972	.141	5/8	1	1 3/4	4 15/16
	1	1 1/8	1.500	1/2	7/8**	1/2	1	1/4-28	3/4-16	2.472	.313	7/8	1 3/8	2 1/8	5 5/16
2 1/2	1 3/8	1 5/8	2.000	5/8	1 1/8	5/8	1 1/4	—	1-14	2.972	.313	1	1 5/8	2 3/8	5 9/16
	5/8	3/4	1.125	3/8	1/2**	—	—	10-32	7/16-20	1.972	.141	5/8	1	1 3/4	5 1/16
	1	1 1/8	1.500	1/2	7/8**	—	—	1/4-28	3/4-16	2.472	.313	7/8	1 3/8	2 1/8	5 1/16
3 1/4	1 3/8	1 5/8	2.000	5/8	1 1/8	5/8	1 1/4	1/4-28	1-14	2.972	.313	1	1 5/8	2 3/8	5 11/16
	1 3/4	2	2.375	3/4	1 1/2	3/4	1 1/2	—	1 1/4-12	3.470	.313	1 1/8	1 7/8	2 5/8	6
	2	2 1/4	2.625	7/8	1 11/16	1/2	1 3/8	1/4-28	1 1/2-12	3.720	.313	1 1/8	2	2 7/8	6 1/4
4	1	1 1/8	1.500	1/2	7/8**	—	—	1/4-28	3/4-16	2.472	.313	7/8	1 3/8	2 1/4	6 1/2
	1 3/8	1 5/8	2.000	5/8	1 1/8	—	—	1/4-28	1-14	2.972	.313	1	1 5/8	2 1/2	6 3/8
	1 3/4	2	2.375	3/4	1 1/2	—	—	1/4-28	1 1/4-12	3.470	.313	1 1/8	1 7/8	2 3/4	6 5/8
5	2	2 1/4	2.625	7/8	1 11/16	—	—	1/4-28	1 1/2-12	3.720	.313	1 1/8	2	2 7/8	6 7/8
	2 1/2	3	3.125	1	2 1/16	—	—	1/4-28	1 7/8-12	4.252	.313	1 1/4	2 1/4	3 1/8	6 7/8
	3	3 1/2	3.750	1	2 5/8	5/8	1 5/8	1/4-28	2 1/4-12	4.752	.313	1 1/4	2 1/4	3 1/8	6 5/16
	3 1/2	3 1/2	4.250	1	3	5/8	1 5/8	1/4-28	2 1/2-12	5.252	.313	1 1/4	2 1/4	3 1/8	6 9/16
	1 3/8	1 5/8	2.000	5/8	1 1/8	—	—	1/4-28	1-14	2.972	.313	1	1 5/8	2 1/2	6 13/16
	1 3/4	2	2.375	3/4	1 1/2	—	—	1/4-28	1 1/4-12	3.470	.313	1 1/8	1 7/8	2 3/4	6 15/16
6	2	2 1/4	2.625	7/8	1 11/16	—	—	1/4-28	1 1/2-12	3.720	.313	1 1/8	2	3	6 15/16
	2 1/2	3	3.125	1	2 1/16	—	—	1/4-28	1 7/8-12	4.252	.313	1 1/4	2 1/4	3 1/4	7 1/16
	3	3 1/2	3.750	1	2 5/8	—	—	1/4-28	2 1/4-12	4.752	.313	1 1/4	2 1/4	3 1/4	7 1/16
	3 1/2	3 1/2	4.250	1	3	—	—	1/4-28	2 1/2-12	5.252	.313	1 1/4	2 1/4	3 1/4	7 1/16
	4	4	4.750	1	3 3/8	1/2	1 1/2	5/16-24	3-12	5.939	.610	1 1/4	2 1/4	3 1/4	7 1/16
	1 3/8	1 5/8	2.000	5/8	1 1/8	—	—	1/4-28	1-14	2.972	.313	1	1 5/8	2 5/8	7 3/16
7	1 3/4	2	2.375	3/4	1 1/2	—	—	1/4-28	1 1/4-12	3.470	.313	1 1/8	1 7/8	2 7/8	7 9/16
	2	2 1/4	2.625	7/8	1 11/16	—	—	1/4-28	1 1/2-12	3.720	.313	1 1/8	2	3	7 11/16
	2 1/2	3	3.125	1	2 1/16	—	—	1/4-28	1 7/8-12	4.252	.313	1 1/4	2 1/4	3 1/4	7 11/16
	3	3 1/2	3.750	1	2 5/8	—	—	1/4-28	2 1/4-12	4.752	.313	1 1/4	2 1/4	3 1/4	7 11/16
	3 1/2	3 1/2	4.250	1	3	—	—	1/4-28	2 1/2-12	5.252	.313	1 1/4	2 1/4	3 1/4	7 11/16
	4	4	4.750	1	3 3/8	—	—	5/16-24	3-12	5.939	.610	1 1/4	2 1/4	3 1/4	7 15/16
	4 1/2	4 1/2	5.250	1	3 7/8	—	—	5/16-24	3 1/4-12	6.439	.610	1 1/4	2 1/4	3 1/4	7 15/16
	5	5	5.750	1	4 1/4	—	—	5/16-24	3 1/2-12	6.939	.610	1 1/4	2 1/4	3 1/4	7 15/16

** For Style #1 Rod End, 5/8 Rod Dia. — D=7/16". 1" Rod Dia. — D=13/16"

Add Stroke

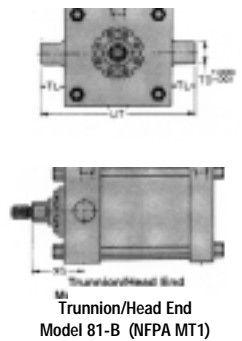

Miller Series A Air Cylinders & Series J Hydraulic Cylinders

Trunnion/Cap End
1½" – 7" Bore Cylinders

Model 82-B (NFPA MT2) Bolted Bushing Trunnion Cap End

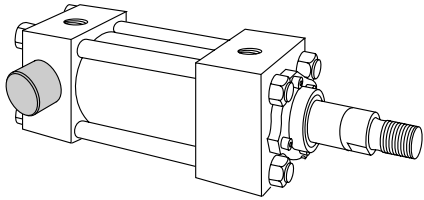

Mounting Dimensions (See tables on opposite page)

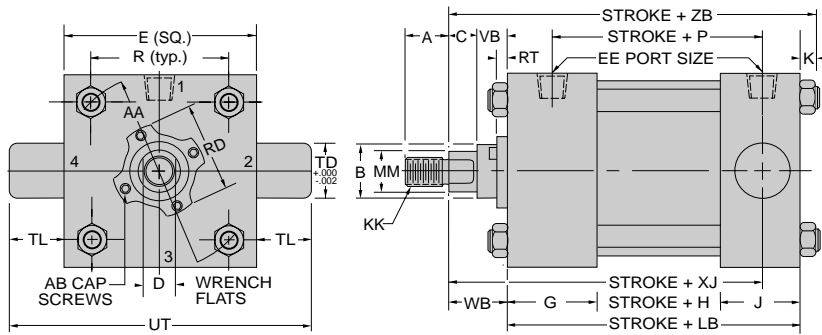

Note: Hard chrome-plated pins designed for shear, (not bending) loads.

Model 82-R (NFPA MT2) Square Retainer Held Bushing Trunnion Cap End

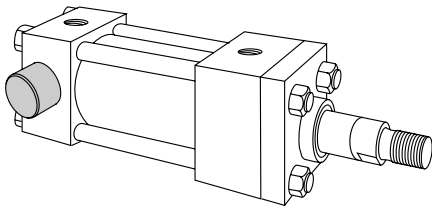

Mounting Dimensions (See tables on opposite page)

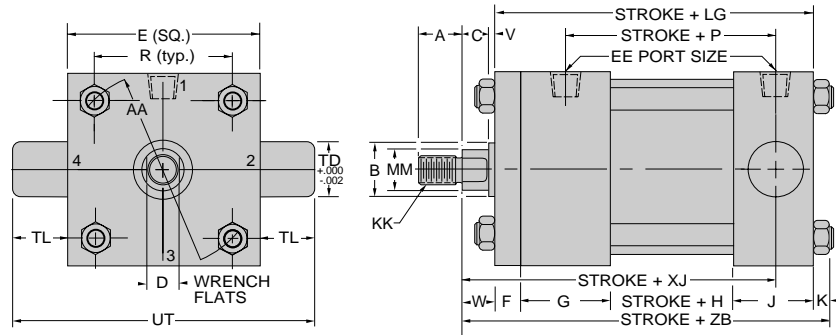

Note: Hard chrome-plated pins designed for shear, (not bending) loads.

Common Rod End Styles & Dimensions (See page 56 for complete listing of rod end styles.)

Style No. 2-Standard Threaded on Turndown Section

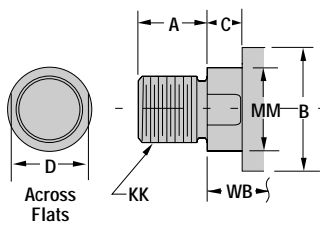

Style No. 4 Short Rod End-Internal Threads

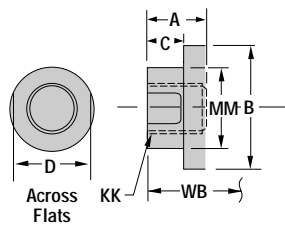

Style No. 6 Studded Rod End

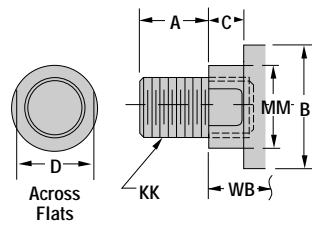

Pressure Limitations for Model 81-82 Trunnion Mounts

BORE	PRESSURE LIMITATIONS	
	MODERATE PSI	SEVERE PSI
1½	2500	1500
2	2500	1500
2½	1500	1000
3¼	1770	1060
4	1170	700
5	750	450
6	1030	610
7	750	450

Note: Pins are designed for shear, (not bending) loads.
* Note: Minimum "XI" dimension values shown apply only to the standard rod diameter. When oversized rods are used, minimum "XI" dimensions are increased by the difference between the "WB" dimension for the oversized rod and the "WB" dimension for the standard rod diameter.
** Note: Consult Miller Fluid Power's Engineering Department for shorter stroke requirements.

Miller Series A Air Cylinders & Series J Hydraulic Cylinders

Trunnion/Cap End
1½" – 7" Bore Cylinders

Model 82 Bolted Bushing and Retainer Construction

Bore Size	AA	E	EE	F	G	J	K	R	TD	TL	UT
1½	2.02	2	⅜-18	⅜	1½	1	¼	1.43	1	1	4
2	2.60	2½	⅜-18	⅜	1½	1	⅝ ₁₆	1.84	1	1	4½
2½	3.10	3	⅜-18	⅜	1½	1	⅝ ₁₆	2.19	1	1	5
3¼	3.90	3¾	½-14	⅝	1¾	1¼	⅜	2.76	1	1	5¾
4	4.70	4½	½-14	⅝	1¾	1¼	⅜	3.32	1	1	6½
5	5.80	5½	½-14	⅝	1¾	1¼	7 ₁₆	4.10	1	1	7½
6	6.90	6½	¾-14	¾	2	1½	7 ₁₆	4.88	1¾	1¾	9¼
7	8.10	7½	¾-14	1	2	1½	9 ₁₆	5.73	1¾	1¾	10¼

Stroke Plus

H	P	LB	LG
1½	2¼	3⅝	4
1½	2¼	3⅝	4
1¼	2⅝	3¾	4⅛
1¼	2⅝	4¼	4⅞
1¼	2⅝	4¼	4⅞
1½	2⅞	4½	5⅞
1½	3⅛	5	5¾
1⅝	3¼	5⅞	-

Rod End Dimensions

Bore Size	Rod Dia (MM)	A	B -.001 to -.003	C	D	V	W	AB	KK Styles 2,4&6	RD (Max.)	RT	VB	WB
1½	⅝	¾	1.125	⅜	½**	¼	⅝	10-32	7 ₁₆ -20	1.972	.141	⅝	1
	1	1⅛	1.500	½	7 ₈ **	½	1	—	¾-16	2.472	.313	7 ₈	1⅜
2	⅝	¾	1.125	⅜	½**	—	—	10-32	7 ₁₆ -20	1.972	.141	⅝	1
	1	1⅛	1.500	½	7 ₈ **	½	1	¼-28	¾-16	2.472	.313	7 ₈	1⅜
	1⅜	1⅝	2.000	⅝	1⅛	⅝	1¼	—	1-14	2.972	.313	1	1⅝
2½	⅝	¾	1.125	⅜	½**	—	—	10-32	7 ₁₆ -20	1.972	.141	⅝	1
	1	1⅛	1.500	½	7 ₈ **	—	—	¼-28	¾-16	2.472	.313	7 ₈	1⅜
	1⅜	1⅝	2.000	⅝	1⅛	⅝	1¼	¼-28	1-14	2.972	.313	1	1⅝
	1¾	2	2.375	¾	1½	¾	1½	—	1¼-12	3.470	.313	1⅞	1⅞
3¼	1	1⅛	1.500	½	7 ₈ **	—	—	¼-28	¾-16	2.472	.313	7 ₈	1⅜
	1⅜	1⅝	2.000	⅝	1⅛	—	—	¼-28	1-14	2.972	.313	1	1⅝
	1¾	2	2.375	¾	1½	½	1¼	¼-28	1¼-12	3.470	.313	1⅞	1⅞
	2	2¼	2.625	7 ₈	1⅞ ₁₆	½	1⅜	¼-28	1½-12	3.720	.313	1⅞	2
4	1	1⅛	1.500	½	7 ₈ **	—	—	¼-28	¾-16	2.472	.313	7 ₈	1⅜
	1⅜	1⅝	2.000	⅝	1⅛	—	—	¼-28	1-14	2.972	.313	1	1⅝
	1¾	2	2.375	¾	1½	—	—	¼-28	1¼-12	3.470	.313	1⅞	1⅞
	2	2¼	2.625	7 ₈	1⅞ ₁₆	—	—	¼-28	1½-12	3.720	.313	1⅞	2
	2½	3	3.125	1	2⅞ ₁₆	⅝	1⅝	¼-28	1⅞-12	4.252	.313	1¼	2¼
5	1	1⅛	1.500	½	7 ₈ **	—	—	¼-28	¾-16	2.472	.313	7 ₈	1⅜
	1⅜	1⅝	2.000	⅝	1⅛	—	—	¼-28	1-14	2.972	.313	1	1⅝
	1¾	2	2.375	¾	1½	—	—	¼-28	1¼-12	3.470	.313	1⅞	1⅞
	2	2¼	2.625	7 ₈	1⅞ ₁₆	—	—	¼-28	1½-12	3.720	.313	1⅞	2
	2½	3	3.125	1	2⅞ ₁₆	—	—	¼-28	1⅞-12	4.252	.313	1¼	2¼
	3	3½	3.750	1	2⅝	⅝	1⅝	¼-28	2¼-12	4.752	.313	1¼	2¼
6	1⅜	1⅝	2.000	⅝	1⅛	—	—	¼-28	1-14	2.972	.313	1	1⅝
	1¾	2	2.375	¾	1½	—	—	¼-28	1¼-12	3.470	.313	1⅞	1⅞
	2	2¼	2.625	7 ₈	1⅞ ₁₆	—	—	¼-28	1½-12	3.720	.313	1⅞	2
	2½	3	3.125	1	2⅞ ₁₆	—	—	¼-28	1⅞-12	4.252	.313	1¼	2¼
	3	3½	3.750	1	2⅝	—	—	¼-28	2¼-12	4.752	.313	1¼	2¼
	3½	3⅞	4.250	1	3	—	—	¼-28	2½-12	5.252	.313	1¼	2¼
	4	4	4.750	1	3⅜	½	1½	⅝ ₁₆ -24	3-12	5.939	.610	1¼	2¼
	4½	4½	5.250	1	3⅞	—	—	⅝ ₁₆ -24	3¼-12	6.439	.610	1¼	2¼
7	1⅜	1⅝	2.000	⅝	1⅛	—	—	¼-28	1-14	2.972	.313	1	1⅝
	1¾	2	2.375	¾	1½	—	—	¼-28	1¼-12	3.470	.313	1⅞	1⅞
	2	2¼	2.625	7 ₈	1⅞ ₁₆	—	—	¼-28	1½-12	3.720	.313	1⅞	2
	2½	3	3.125	1	2⅞ ₁₆	—	—	¼-28	1⅞-12	4.252	.313	1¼	2¼
	3	3½	3.750	1	2⅝	—	—	¼-28	2¼-12	4.752	.313	1¼	2¼
	3½	3⅞	4.250	1	3	—	—	¼-28	2½-12	5.252	.313	1¼	2¼
	4	4	4.750	1	3⅜	—	—	⅝ ₁₆ -24	3-12	5.939	.610	1¼	2¼
	4½	4½	5.250	1	3⅞	—	—	⅝ ₁₆ -24	3¼-12	6.439	.610	1¼	2¼

** For Style #1 Rod End, ⅝ Rod Dia. — D=7₁₆". 1" Rod Dia. — D=13₁₆"

Add Stroke

XJ	ZB
4⅞	4⅞
4½	5¼
4¼	4 ¹⁵ / ₁₆
4½	5 ⁵ / ₁₆
4¾	5 ⁹ / ₁₆
4¼	5 ¹ / ₁₆
4⅝	5 ⁷ / ₁₆
4⅞	5 ¹¹ / ₁₆
5⅞	5 ¹⁵ / ₁₆
5	6
5¼	6¼
5½	6½
5⅝	6 ⁵ / ₈
5⅞	6 ⁷ / ₈
5¼	6 ⁵ / ₁₆
5½	6 ⁹ / ₁₆
5¾	6 ¹³ / ₁₆
5⅞	6 ¹⁵ / ₁₆
6⅞	7 ³ / ₁₆
6⅞	7 ³ / ₁₆
6⅞	7 ³ / ₁₆
5⅞	7 ¹ / ₁₆
6⅞	7 ⁵ / ₁₆
6¼	7 ⁷ / ₁₆
6½	7 ¹¹ / ₁₆
6½	7 ¹¹ / ₁₆
6½	7 ¹¹ / ₁₆
6½	7 ¹¹ / ₁₆
6	7 ⁵ / ₁₆
6¼	7 ⁹ / ₁₆
6⅜	7 ¹¹ / ₁₆
6⅝	7 ¹⁵ / ₁₆
6⅝	7 ¹⁵ / ₁₆
6⅝	7 ¹⁵ / ₁₆
6⅝	7 ¹⁵ / ₁₆
6⅝	7 ¹⁵ / ₁₆

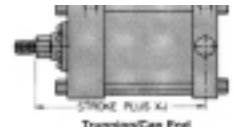

Trunnion/Cap End
Model 82-B (NFPA MT2)

Miller Series A Air Cylinders & Series J Hydraulic Cylinders

Intermediate Trunnion
1½" – 7" Bore Cylinders

Model 89-B (NFPA MT4) Bolted Bushing Intermediate Trunnion

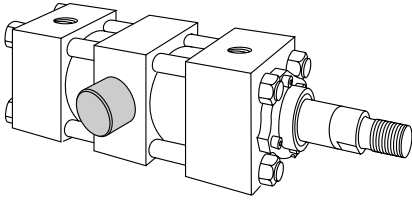

Note: Hard chrome-plate pins designed for shear, (not bending) loads.
Specify dimension "XI" when ordering.

Mounting Dimensions (See tables on opposite page)

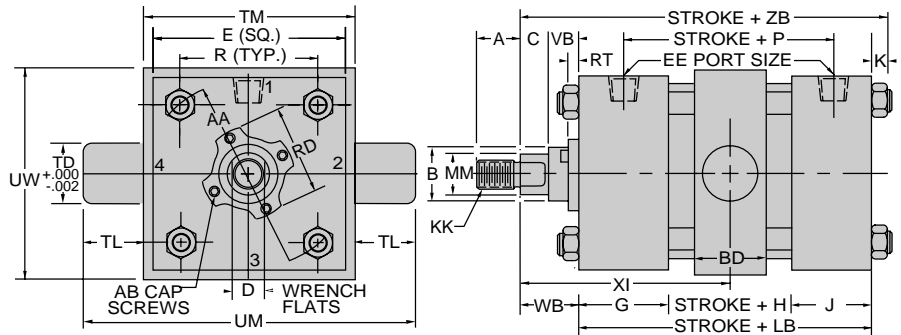

Model 89-R (NFPA MT4) Square Retainer Held Bushing Intermediate Trunnion

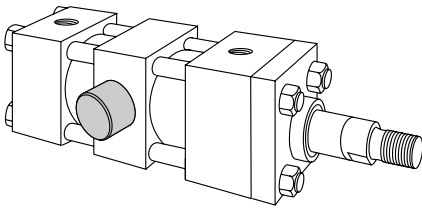

Note: Hard chrome-plated pins designed for shear, (not bending) loads.
Specify dimension "XI" when ordering.

Mounting Dimensions (See tables on opposite page)

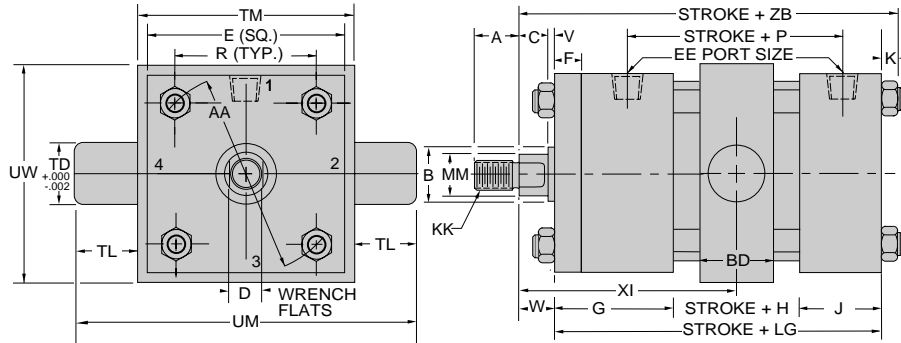

Common Rod End Styles & Dimensions (See page 56 for complete listing of rod end styles.)

Style No. 2-Standard Threaded on Turndown Section

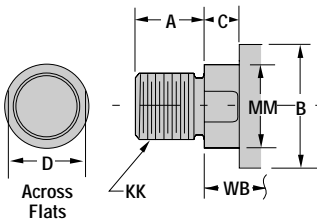

Style No. 4 Short Rod End-Internal Threads

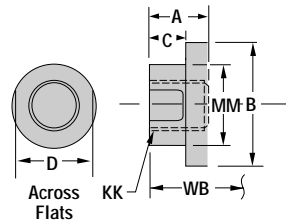

Style No. 6 Studded Rod End

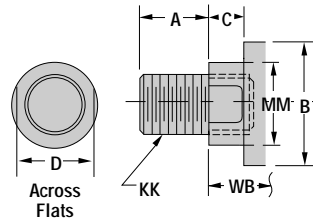

Pressure Limitations for Model **89 Trunnion Mounts

BORE	PRESSURE LIMITATIONS	
	MODERATE	SEVERE
	PSI	PSI
1½	2500	1500
2	2500	1500
2½	1500	1000
3¼	1550	930
4	1030	610
5	660	390
6	800	500
7	660	390

Note: Pins are designed for shear, (not bending) loads.

* **Note:** Minimum "XI" dimension values shown apply only to the standard rod diameter. When oversized rods are used, minimum "XI" dimensions are increased by the difference between the "WB" dimension for the oversized rod and the "WB" dimension for the standard rod diameter.

** **Note:** Consult Miller Fluid Power's Engineering Department for shorter stroke requirements.

Miller Series A Air Cylinders & Series J Hydraulic Cylinders

Intermediate Trunnion 1½" – 7" Bore Cylinders

Model 89 Bolted Bushing and Retainer Construction

Stroke Plus

Bore Size	AA	E	EE	F	G	J	K	R	BD	TD	TL	TM	UM	UW	MODEL 89		H	P	LB	‡LD	LG
															XI (MIN.)	MIN. STROKE					
1½	2.02	2	¾-18	¾	1½	1	¼	1.43	1½	1	1	2½	4½	2½	3.25	6.375	1½	2¼	3⅝	4⅞	4
2	2.60	2½	¾-18	¾	1½	1	⅕	1.84	1½	1	1	3	5	3	3.25	0.375	1½	2¼	3⅝	4⅞	4
2½	3.10	3	¾-18	¾	1½	1	⅕	2.19	1½	1	1	3½	5½	3½	3.25	0.250	1¾	2⅝	3¾	4¼	4⅞
3¼	3.90	3¾	½-14	⅝	1¾	1¼	⅜	2.76	2	1	1	4½	6½	4½	4.125	8.750	1¼	2⅝	4¼	4¾	4⅞
4	4.70	4½	½-14	⅝	1¾	1¼	⅜	3.32	2	1	1	5¼	7¼	5	4.125	0.750	1¼	2⅝	4¼	4¾	4⅞
5	5.80	5½	½-14	⅝	1¾	1¼	⅞	4.10	2	1	1	6¼	8¼	6½	4.125	.0500	1½	2⅞	4½	5	5⅞
6	6.90	6½	¾-14	¾	2	1½	⅞	4.88	2¼	1⅜	1⅜	7⅝	10⅜	7½	4.75	0.750	1½	3⅞	5	5½	5¾
7	8.10	7½	¾-14	1	2	1½	⅞	5.73	4¾	1⅜	1⅜	8¾	11½	8½	5.00	1.125	1⅝	3¼	5⅞	5⅞	-

‡ LD Dimension is for double rod end models. See page 40.

Rod End Dimensions

Add Stroke

Bore Size	Rod Dia (MM)	A	B -.001 to -.003	C	D	V	W	AB	KK Styles 2,4&6	RD (Max.)	RT	VB	WB
1½	⅝	¾	1.125	¾	½**	¼	⅝	10-32	⅞-20	1.972	.141	⅝	1
	1	1⅞	1.500	½	⅞**	½	1	—	¾-16	2.472	.313	⅞	1⅜
2	⅝	¾	1.125	¾	½**	—	—	10-32	⅞-20	1.972	.141	⅝	1
	1	1⅞	1.500	½	⅞**	½	1	¼-28	¾-16	2.472	.313	⅞	1⅜
	1⅜	1⅝	2.000	⅝	1⅞	⅝	1¼	—	1-14	2.972	.313	1	1⅝
2½	⅝	¾	1.125	¾	½**	—	—	10-32	⅞-20	1.972	.141	⅝	1
	1	1⅞	1.500	½	⅞**	—	—	¼-28	¾-16	2.472	.313	⅞	1⅜
	1⅜	1⅝	2.000	⅝	1⅞	⅝	1¼	¼-28	1-14	2.972	.313	1	1⅝
3¼	1⅜	2	2.375	¾	1½	⅜	1½	—	1¼-12	3.470	.313	1⅞	1⅞
	1	1⅞	1.500	½	⅞**	—	—	¼-28	¾-16	2.472	.313	⅞	1⅜
	1⅜	1⅝	2.000	⅝	1⅞	—	—	¼-28	1-14	2.972	.313	1	1⅝
4	1⅜	2	2.375	¾	1½	⅜	1½	—	1¼-12	3.470	.313	1⅞	1⅞
	2	2¼	2.625	⅞	1⅞	½	1⅞	¼-28	1½-12	3.720	.313	1⅞	2
	1	1⅞	1.500	½	⅞**	—	—	¼-28	¾-16	2.472	.313	⅞	1⅜
	1⅜	1⅝	2.000	⅝	1⅞	—	—	¼-28	1-14	2.972	.313	1	1⅝
5	1⅜	2	2.375	¾	1½	—	—	¼-28	1¼-12	3.470	.313	1⅞	1⅞
	2	2¼	2.625	⅞	1⅞	—	—	¼-28	1½-12	3.720	.313	1⅞	2
	2½	3	3.125	1	2⅞	—	—	¼-28	1⅞-12	4.252	.313	1⅞	2
	3	3½	3.750	1	2⅞	⅝	1⅞	¼-28	2¼-12	4.752	.313	1¼	2¼
	3½	3½	4.250	1	3	⅝	1⅞	¼-28	2½-12	5.252	.313	1¼	2¼
	4	4	4.750	1	3⅞	—	—	¼-28	2⅞-12	5.752	.313	1¼	2¼
6	1⅜	1⅝	2.000	⅝	1⅞	—	—	¼-28	1-14	2.972	.313	1	1⅝
	1⅜	2	2.375	¾	1½	—	—	¼-28	1¼-12	3.470	.313	1⅞	1⅞
	2	2¼	2.625	⅞	1⅞	—	—	¼-28	1½-12	3.720	.313	1⅞	2
	2½	3	3.125	1	2⅞	—	—	¼-28	1⅞-12	4.252	.313	1¼	2¼
	3	3½	3.750	1	2⅞	—	—	¼-28	2¼-12	4.752	.313	1¼	2¼
	3½	3½	4.250	1	3	—	—	¼-28	2½-12	5.252	.313	1¼	2¼
	4	4	4.750	1	3⅞	½	1½	⅝-24	3-12	5.939	.610	1¼	2¼
	1⅜	1⅝	2.000	⅝	1⅞	—	—	¼-28	1-14	2.972	.313	1	1⅝
7	1⅜	2	2.375	¾	1½	—	—	¼-28	1¼-12	3.470	.313	1⅞	1⅞
	2	2¼	2.625	⅞	1⅞	—	—	¼-28	1½-12	3.720	.313	1⅞	2
	2½	3	3.125	1	2⅞	—	—	¼-28	1⅞-12	4.252	.313	1¼	2¼
	3	3½	3.750	1	2⅞	—	—	¼-28	2¼-12	4.752	.313	1¼	2¼
	3½	3½	4.250	1	3	—	—	¼-28	2½-12	5.252	.313	1¼	2¼
	4	4	4.750	1	3⅞	—	—	⅝-24	3-12	5.939	.610	1¼	2¼
	4½	4½	5.250	1	3⅞	—	—	⅝-24	3¼-12	6.439	.610	1¼	2¼
	5	5	5.750	1	4¼	—	—	⅝-24	3½-12	6.939	.610	1¼	2¼

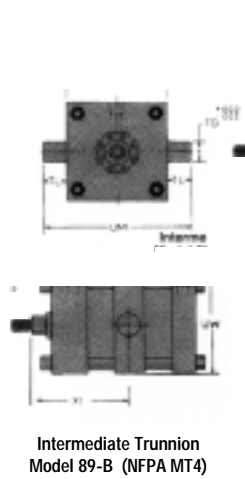

Note: Pins are designed for shear, (not bending) loads.
 * Note: Minimum "XI" dimension values shown apply only to the standard rod diameter. When oversized rods are used, minimum "XI" dimensions are increased by the difference between the "WB" dimension for the oversized rod and the "WB" dimension for the standard rod diameter.
 ** Note: Consult Miller Fluid Power's Engineering Department for shorter stroke requirements.

** For Style #1 Rod End, ⅝ Rod Dia. — D=⅞". 1" Rod Dia. — D=1⅜"

Miller Series A Air Cylinders & Series J Hydraulic Cylinders

Fixed Clevis
1½" – 7" Bore Cylinders

Model 84-B (NFPA MP1)
Bolted Bushing
Fixed Clevis
(Pivot Pin Included)

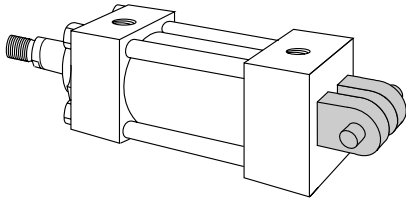

Mounting Dimensions
(See tables on opposite page)

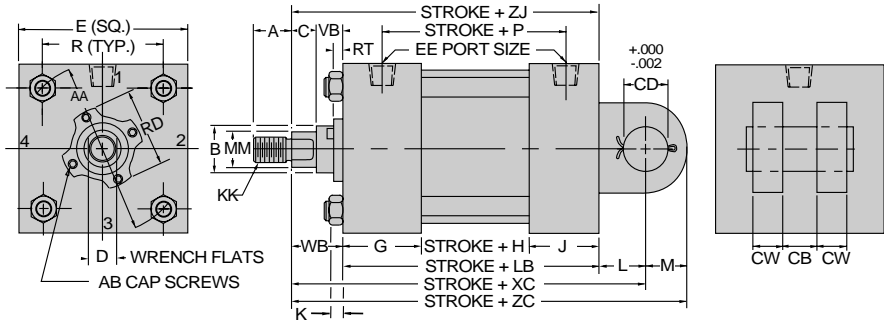

Model 84-R (NFPA MP1)
Square Retainer Held Bushing
Fixed Clevis
(Pivot Pin Included)

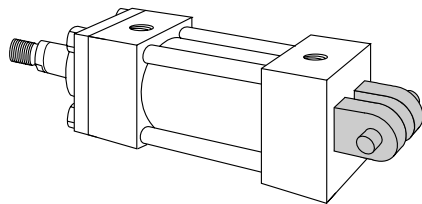

Mounting Dimensions
(See tables on opposite page)

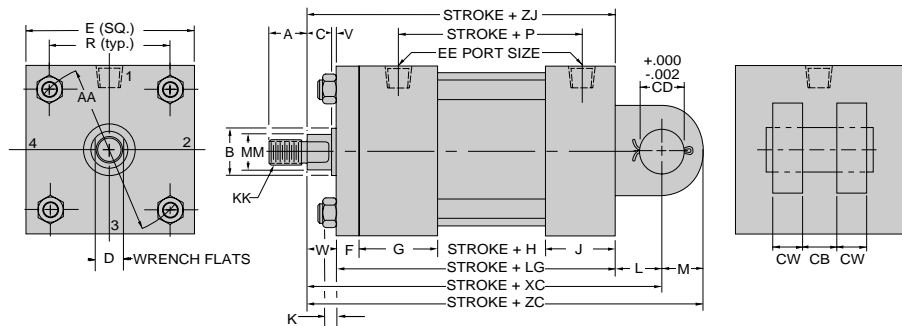

Common Rod End Styles & Dimensions (See page 56 for complete listing of rod end styles.)

Style No. 2-Standard
Threaded on Turndown Section

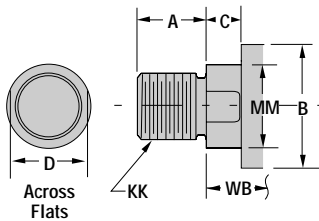

Style No. 4
Short Rod End-Internal Threads

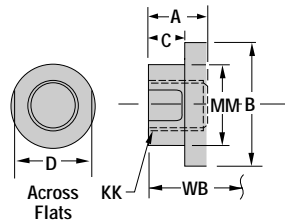

Style No. 6
Studded Rod End

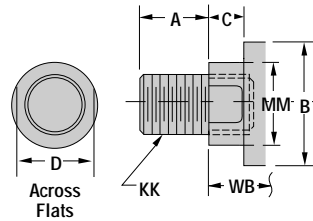

Miller Series A Air Cylinders & Series J Hydraulic Cylinders

Fixed Clevis 1½" – 7" Bore Cylinders

Model 84 Bolted Bushing and Retainer Construction

Stroke Plus

Bore Size	AA	E	EE	F	G	J	K	R	CB	CD	CW	L	M
1½	2.02	2	¾-18	¾	1½	1	¼	1.43	¾	½	½	¾	½
2	2.60	2½	¾-18	¾	1½	1	5/16	1.84	¾	½	½	¾	½
2½	3.10	3	¾-18	¾	1½	1	5/16	2.19	¾	½	½	¾	½
3¼	3.90	3¾	½-14	5/8	1¾	1¼	¾	2.76	1¼	¾	5/8	1¼	¾
4	4.70	4½	½-14	5/8	1¾	1¼	¾	3.32	1¼	¾	5/8	1¼	¾
5	5.80	5½	½-14	5/8	1¾	1¼	7/16	4.10	1¼	¾	5/8	1¼	¾
6	6.90	6½	¾-14	¾	2	1½	7/16	4.88	1½	1	¾	1½	1
7	8.10	7½	¾-14	1	2	1½	9/16	5.73	1½	1	¾	1½	1

H	P	LB	LG
1½	2¼	3⅝	4
1½	2¼	3⅝	4
1¼	2⅜	3¾	4⅞
1¼	2⅝	4¼	4⅞
1¼	2⅝	4¼	4⅞
1½	2⅞	4½	5⅞
1½	3⅞	5	5¾
1⅝	3¼	5⅞	-

Rod End Dimensions

Bore Size	Rod Dia (MM)	A	B -.001 to -.003	C	D	V	W	AB	KK Styles 2,4&6	RD (Max.)	RT	VB	WB
1½	5/8	¾	1.125	¾	1½**	¼	5/8	10-32	7/16-20	1.972	.141	5/8	1
	1	1⅞	1.500	½	7/8**	½	1	—	¾-16	2.472	.313	7/8	1⅜
2	5/8	¾	1.125	¾	1½**	—	—	10-32	7/16-20	1.972	.141	5/8	1
	1	1⅞	1.500	½	7/8**	½	1	¼-28	¾-16	2.472	.313	7/8	1⅜
	1⅜	1⅝	2.000	5/8	1⅞	5/8	1¼	—	1-14	2.972	.313	1	1⅝
2½	5/8	¾	1.125	¾	1½**	—	—	10-32	7/16-20	1.972	.141	5/8	1
	1	1⅞	1.500	½	7/8**	—	—	¼-28	¾-16	2.472	.313	7/8	1⅜
	1⅜	1⅝	2.000	5/8	1⅞	5/8	1¼	¼-28	1-14	2.972	.313	1	1⅝
	1¾	2	2.375	¾	1½	¾	1½	—	1¼-12	3.470	.313	1⅞	1⅞
3¼	1	1⅞	1.500	½	7/8**	—	—	¼-28	¾-16	2.472	.313	7/8	1⅜
	1⅜	1⅝	2.000	5/8	1⅞	—	—	¼-28	1-14	2.972	.313	1	1⅝
	1¾	2	2.375	¾	1½	½	1¼	¼-28	1¼-12	3.470	.313	1⅞	1⅞
	2	2¼	2.625	7/8	1⅞	½	1⅜	¼-28	1½-12	3.720	.313	1⅞	2
4	1	1⅞	1.500	½	7/8**	—	—	¼-28	¾-16	2.472	.313	7/8	1⅜
	1⅜	1⅝	2.000	5/8	1⅞	—	—	¼-28	1-14	2.972	.313	1	1⅝
	1¾	2	2.375	¾	1½	—	—	¼-28	1¼-12	3.470	.313	1⅞	1⅞
	2	2¼	2.625	7/8	1⅞	—	—	¼-28	1½-12	3.720	.313	1⅞	2
	2½	3	3.125	1	2⅞	5/8	1⅝	¼-28	1⅞-12	4.252	.313	1¼	2¼
	3	3½	3.750	1	3	5/8	1⅝	¼-28	2⅞-12	5.252	.313	1¼	2¼
5	1	1⅞	1.500	½	7/8**	—	—	¼-28	¾-16	2.472	.313	7/8	1⅜
	1⅜	1⅝	2.000	5/8	1⅞	—	—	¼-28	1-14	2.972	.313	1	1⅝
	1¾	2	2.375	¾	1½	—	—	¼-28	1¼-12	3.470	.313	1⅞	1⅞
	2	2¼	2.625	7/8	1⅞	—	—	¼-28	1½-12	3.720	.313	1⅞	2
	2½	3	3.125	1	2⅞	—	—	¼-28	1⅞-12	4.252	.313	1¼	2¼
	3	3½	3.750	1	3	5/8	1⅝	¼-28	2⅞-12	5.252	.313	1¼	2¼
	3½	3½	4.250	1	3	5/8	1⅝	¼-28	2⅞-12	5.252	.313	1¼	2¼
6	1⅜	1⅝	2.000	5/8	1⅞	—	—	¼-28	1-14	2.972	.313	1	1⅝
	1¾	2	2.375	¾	1½	—	—	¼-28	1¼-12	3.470	.313	1⅞	1⅞
	2	2¼	2.625	7/8	1⅞	—	—	¼-28	1½-12	3.720	.313	1⅞	2
	2½	3	3.125	1	2⅞	—	—	¼-28	1⅞-12	4.252	.313	1¼	2¼
	3	3½	3.750	1	3	—	—	¼-28	2⅞-12	5.252	.313	1¼	2¼
	3½	3½	4.250	1	3	—	—	¼-28	2⅞-12	5.252	.313	1¼	2¼
	4	4	4.750	1	3⅞	½	1½	5/16-24	3-12	5.939	.610	1¼	2¼
	4½	4½	5.250	1	3⅞	—	—	5/16-24	3¼-12	6.439	.610	1¼	2¼
7	1⅜	1⅝	2.000	5/8	1⅞	—	—	¼-28	1-14	2.972	.313	1	1⅝
	1¾	2	2.375	¾	1½	—	—	¼-28	1¼-12	3.470	.313	1⅞	1⅞
	2	2¼	2.625	7/8	1⅞	—	—	¼-28	1½-12	3.720	.313	1⅞	2
	2½	3	3.125	1	2⅞	—	—	¼-28	1⅞-12	4.252	.313	1¼	2¼
	3	3½	3.750	1	3	—	—	¼-28	2⅞-12	5.252	.313	1¼	2¼
	3½	3½	4.250	1	3	—	—	¼-28	2⅞-12	5.252	.313	1¼	2¼
	4	4	4.750	1	3⅞	—	—	5/16-24	3-12	5.939	.610	1¼	2¼
	4½	4½	5.250	1	3⅞	—	—	5/16-24	3¼-12	6.439	.610	1¼	2¼
	5	5	5.750	1	4¼	—	—	5/16-24	3½-12	6.939	.610	1¼	2¼

** For Style #1 Rod End, 5/8 Rod Dia. — D=7/16". 1" Rod Dia. — D=13/16"

Add Stroke

XC	ZC	ZJ
5⅜	5⅞	4⅝
5¾	6¼	5
5⅞	5⅞	4⅞
5¾	6¼	5
6	6½	5¼
5½	6	4¾
5⅞	6⅜	5⅞
6⅞	6⅝	5⅜
6⅞	6⅞	5⅞
7⅞	7⅞	5⅞
7⅞	8⅞	6⅞
7½	8¼	6¼
6⅞	7⅝	5⅞
7⅞	7⅞	5⅞
7⅞	8⅞	6⅞
7⅞	8⅞	6⅞
7¾	8½	6½
8	8¾	6¾
8	8¾	6¾
8	8¾	6¾
8⅞	9⅞	6⅞
8⅞	9⅞	6⅞
8½	9½	7
8⅞	9⅞	7⅞
8⅞	9⅞	7⅞
8⅞	9⅞	7⅞
8⅞	9⅞	7⅞
8⅞	9⅞	7⅞
8⅞	9⅞	7⅞

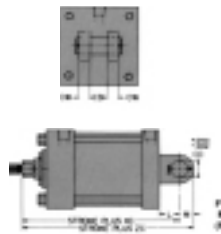

Fixed Clevis
Model 84-B (NFPA MP1)

Miller Series A Air Cylinders & Series J Hydraulic Cylinders

Detachable Clevis
1 1/2" - 7" Bore Cylinders

Model 86-B (NFPA MP2)
Bolted Bushing
Detachable Clevis
(Pivot Pin Included)

Mounting Dimensions
(See tables on opposite page)

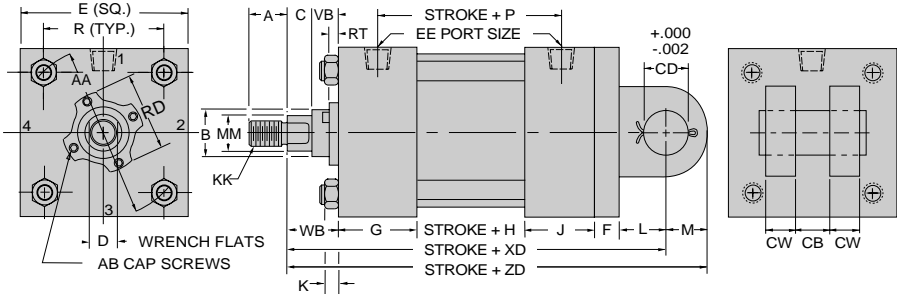
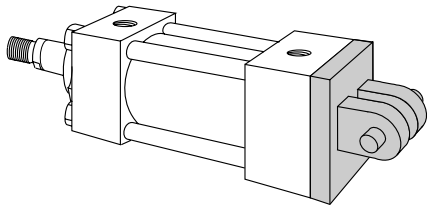

Model 86-R (NFPA MP2)
Square Retainer Held Bushing
Detachable Clevis
(Pivot Pin Included)

Mounting Dimensions
(See tables on opposite page)

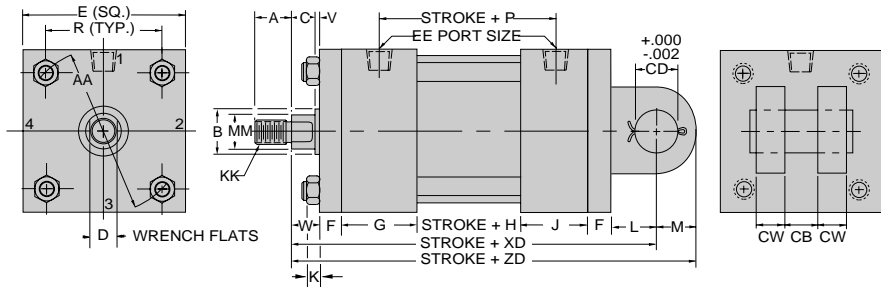
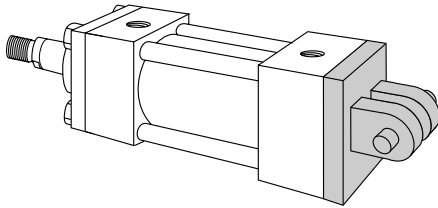

Common Rod End Styles & Dimensions (See page 56 for complete listing of rod end styles.)

Style No. 2-Standard
Threaded on Turndown Section

Style No. 4
Short Rod End-Internal Threads

Style No. 6
Studded Rod End

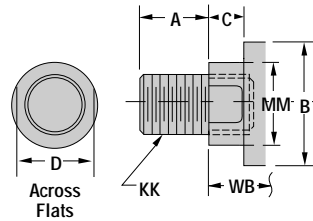
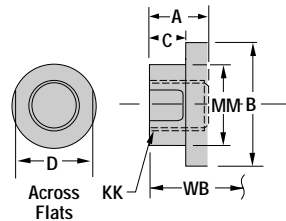
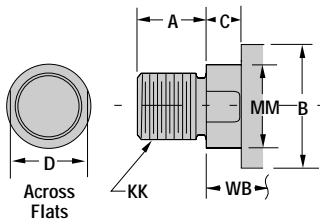

Miller Series A Air Cylinders & Series J Hydraulic Cylinders

Detachable Clevis
1 1/2"-7" Bore Cylinders

Model 86 Bolted Bushing and Retainer Construction

Stroke Plus

Bore Size	AA	E	EE	F	G	J	K	R	CB	CD	CW	L	M	H	P
1 1/2	2.02	2	3/8-18	3/8	1 1/2	1	1/4	1.43	3/4	1/2	1/2	3/4	1/2	1 1/8	2 1/4
2	2.60	2 1/2	3/8-18	3/8	1 1/2	1	5/16	1.84	3/4	1/2	1/2	3/4	1/2	1 1/8	2 1/4
2 1/2	3.10	3	3/8-18	3/8	1 1/2	1	5/16	2.19	3/4	1/2	1/2	3/4	1/2	1 1/4	2 3/8
3 1/4	3.90	3 3/4	1/2-14	5/8	1 3/4	1 1/4	3/8	2.76	1 1/4	3/4	5/8	1 1/4	3/4	1 1/4	2 5/8
4	4.70	4 1/2	1/2-14	5/8	1 3/4	1 1/4	3/8	3.32	1 1/4	3/4	5/8	1 1/4	3/4	1 1/4	2 5/8
5	5.80	5 1/2	1/2-14	5/8	1 3/4	1 1/4	7/16	4.10	1 1/4	3/4	5/8	1 1/4	3/4	1 1/2	2 7/8
6	6.90	6 1/2	3/4-14	3/4	2	1 1/2	7/16	4.88	1 1/2	1	3/4	1 1/2	1	1 1/2	3 1/8
7	8.10	7 1/2	3/4-14	1	2	1 1/2	9/16	5.73	1 1/2	1	3/4	1 1/2	1	1 5/8	3 1/4

Rod End Dimensions

Add Stroke

Bore Size	Rod Dia (MM)	A	B -.001 to -.003	C	D	V	W	AB	KK Styles 2,4&6	RD (Max.)	RT	VB	WB	XD	ZD
1 1/2	5/8	3/4	1.125	3/8	1/2**	1/4	5/8	10-32	7/16-20	1.972	.141	5/8	1	5 3/4	6 1/4
	1	1 1/8	1.500	1/2	7/8**	1/2	1	—	3/4-16	2.472	.313	7/8	1 3/8	6 1/8	6 5/8
2	5/8	3/4	1.125	3/8	1/2**	—	—	10-32	7/16-20	1.972	.141	5/8	1	5 3/4	6 1/4
	1	1 1/8	1.500	1/2	7/8**	1/2	1	1/4-28	3/4-16	2.472	.313	7/8	1 3/8	6 1/8	6 5/8
	1 3/8	1 5/8	2.000	5/8	1 1/8	5/8	1 1/4	—	1-14	2.972	.313	1	1 5/8	6 3/8	6 7/8
2 1/2	5/8	3/4	1.125	3/8	1/2**	—	—	10-32	7/16-20	1.972	.141	5/8	1	5 7/8	6 3/8
	1	1 1/8	1.500	1/2	7/8**	—	—	1/4-28	3/4-16	2.472	.313	7/8	1 3/8	6 1/4	6 3/4
	1 3/8	1 5/8	2.000	5/8	1 1/8	5/8	1 1/4	1/4-28	1-14	2.972	.313	1	1 5/8	6 1/2	7
3 1/4	1 3/8	2	2.375	3/4	1 1/2	3/4	1 1/2	1/4-28	1 1/4-12	3.470	.313	1 1/8	1 7/8	6 3/4	7 1/4
	1	1 1/8	1.500	1/2	7/8**	—	—	1/4-28	3/4-16	2.472	.313	7/8	1 3/8	7 1/2	8 1/4
	1 3/8	1 5/8	2.000	5/8	1 1/8	—	—	1/4-28	1-14	2.972	.313	1	1 5/8	7 3/4	8 1/2
4	1 3/4	2	2.375	3/4	1 1/2	1/2	1 1/4	1/4-28	1 1/4-12	3.470	.313	1 1/8	1 7/8	8	8 3/4
	2	2 1/4	2.625	7/8	1 1/2	1 1/2	1 3/8	1/4-28	1 1/2-12	3.720	.313	1 1/8	2	8 1/8	8 7/8
	1	1 1/8	1.500	1/2	7/8**	—	—	1/4-28	3/4-16	2.472	.313	7/8	1 3/8	7 1/2	8 1/4
	1 3/8	1 5/8	2.000	5/8	1 1/8	—	—	1/4-28	1-14	2.972	.313	1	1 5/8	7 3/4	8 1/2
5	1 3/4	2	2.375	3/4	1 1/2	—	—	1/4-28	1 1/4-12	3.470	.313	1 1/8	1 7/8	8	8 3/4
	2	2 1/4	2.625	7/8	1 1/2	—	—	1/4-28	1 1/2-12	3.720	.313	1 1/8	2	8 1/8	8 7/8
	2 1/2	3	3.125	1	2 1/16	5/8	1 5/8	1/4-28	1 7/8-12	4.252	.313	1 1/4	2 1/4	8 3/8	9 1/8
	1	1 1/8	1.500	1/2	7/8**	—	—	1/4-28	3/4-16	2.472	.313	7/8	1 3/8	7 3/4	8 1/2
	1 3/8	1 5/8	2.000	5/8	1 1/8	—	—	1/4-28	1-14	2.972	.313	1	1 5/8	8	8 3/4
	1 3/4	2	2.375	3/4	1 1/2	—	—	1/4-28	1 1/4-12	3.470	.313	1 1/8	1 7/8	8 1/4	9
6	2	2 1/4	2.625	7/8	1 1/2	—	—	1/4-28	1 1/2-12	3.720	.313	1 1/8	2	8 3/8	9 1/8
	2 1/2	3	3.125	1	2 1/16	—	—	1/4-28	1 7/8-12	4.252	.313	1 1/4	2 1/4	8 5/8	9 3/8
	3	3 1/2	3.750	1	2 5/8	5/8	1 5/8	1/4-28	2 1/4-12	4.752	.313	1 1/4	2 1/4	8 5/8	9 3/8
	3 1/2	3 1/2	4.250	1	3	5/8	1 5/8	1/4-28	2 1/2-12	5.252	.313	1 1/4	2 1/4	8 5/8	9 3/8
	4	4	4.750	1	3 3/8	1/2	1 1/2	5/16-24	3-12	5.939	.610	1 1/4	2 1/4	8 7/8	9 7/8
	1 3/8	1 5/8	2.000	5/8	1 1/8	—	—	1/4-28	1-14	2.972	.313	1	1 5/8	8 7/8	9 7/8
	1 3/4	2	2.375	3/4	1 1/2	—	—	1/4-28	1 1/4-12	3.470	.313	1 1/8	1 7/8	9 1/8	10 1/8
7	2	2 1/4	2.625	7/8	1 1/2	—	—	1/4-28	1 1/2-12	3.720	.313	1 1/8	2	9 1/4	10 1/4
	2 1/2	3	3.125	1	2 1/16	—	—	1/4-28	1 7/8-12	4.252	.313	1 1/4	2 1/4	9 1/2	10 1/2
	3	3 1/2	3.750	1	2 5/8	—	—	1/4-28	2 1/4-12	4.752	.313	1 1/4	2 1/4	9 1/2	10 1/2
	3 1/2	3 1/2	4.250	1	3	—	—	1/4-28	2 1/2-12	5.252	.313	1 1/4	2 1/4	9 1/2	10 1/2
	4	4	4.750	1	3 3/8	—	—	5/16-24	3-12	5.939	.610	1 1/4	2 1/4	9 1/2	10 1/2
	1 3/8	1 5/8	2.000	5/8	1 1/8	—	—	1/4-28	1-14	2.972	.313	1	1 5/8	9 1/4	10 1/4
	1 3/4	2	2.375	3/4	1 1/2	—	—	1/4-28	1 1/4-12	3.470	.313	1 1/8	1 7/8	9 1/2	10 1/2
	2	2 1/4	2.625	7/8	1 1/2	—	—	1/4-28	1 1/2-12	3.720	.313	1 1/8	2	9 5/8	10 5/8
7	2 1/2	3	3.125	1	2 1/16	—	—	1/4-28	1 7/8-12	4.252	.313	1 1/4	2 1/4	9 7/8	10 7/8
	3	3 1/2	3.750	1	2 5/8	—	—	1/4-28	2 1/4-12	4.752	.313	1 1/4	2 1/4	9 7/8	10 7/8
	3 1/2	3 1/2	4.250	1	3	—	—	1/4-28	2 1/2-12	5.252	.313	1 1/4	2 1/4	9 7/8	10 7/8
	4	4	4.750	1	3 3/8	—	—	5/16-24	3-12	5.939	.610	1 1/4	2 1/4	9 7/8	10 7/8
	4 1/2	4 1/2	5.250	1	3 7/8	—	—	5/16-24	3 1/4-12	6.439	.610	1 1/4	2 1/4	9 7/8	10 7/8
5	5	5.750	1	4 1/4	—	—	5/16-24	3 1/2-12	6.939	.610	1 1/4	2 1/4	9 7/8	10 7/8	

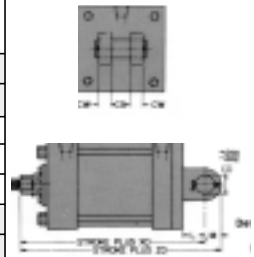

Detachable Clevis
Model 86-B (NFPA MP2)

** For Style #1 Rod End, 5/8 Rod Dia. — D=7/16". 1" Rod Dia. — D=13/16"

Miller Series A Air Cylinders & Series J Hydraulic Cylinders

Rear Eye
1 1/2" - 7" Bore Cylinders

Model 90-B (NFPA MP3)
Bolted Bushing
Rear Eye
(Pivot Pin Included)

Mounting Dimensions
(See tables on opposite page)

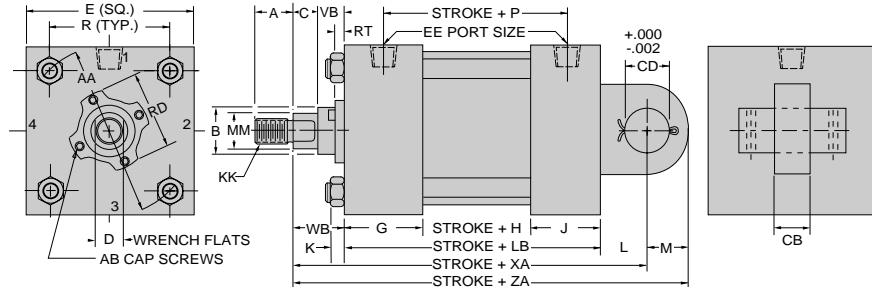
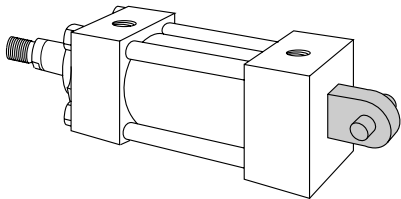

Model 90-R (NFPA MP3)
Square Retainer Held Bushing
Rear Eye
(Pivot Pin Included)

Mounting Dimensions
(See tables on opposite page)

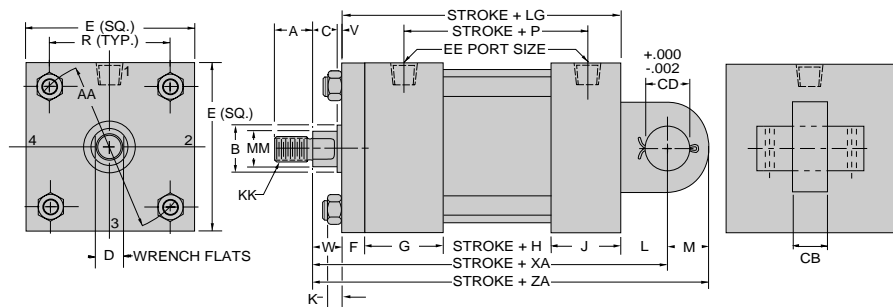
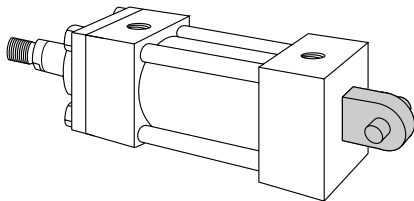

Common Rod End Styles & Dimensions (See page 56 for complete listing of rod end styles.)

Style No. 2-Standard
Threaded on Turndown Section

Style No. 4
Short Rod End-Internal Threads

Style No. 6
Studded Rod End

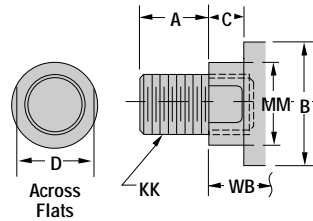
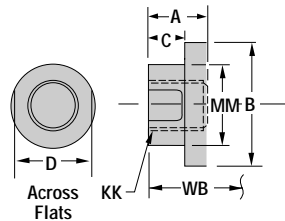
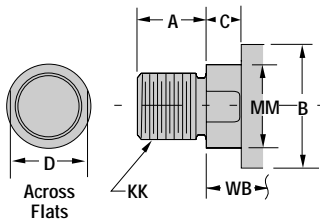

Miller Series A Air Cylinders & Series J Hydraulic Cylinders

Rear Eye
1½" - 7" Bore Cylinders

Model 90 Bolted Bushing and Retainer Construction

Stroke Plus

Bore Size	AA	E	EE	F	G	J	K	R	CB	CD	L	M
1½	2.02	2	¾-18	¾	1½	1	¼	1.43	¾	½	¾	½
2	2.60	2½	¾-18	¾	1½	1	5/16	1.84	¾	½	¾	½
2½	3.10	3	¾-18	¾	1½	1	5/16	2.19	¾	½	¾	½
3¼	3.90	3¾	½-14	5/8	1¾	1¼	¾	2.76	1¼	¾	1¼	¾
4	4.70	4½	½-14	5/8	1¾	1¼	¾	3.32	1¼	¾	1¼	¾
5	5.80	5½	½-14	5/8	1¾	1¼	7/16	4.10	1¼	¾	1¼	¾
6	6.90	6½	¾-14	¾	2	1½	7/16	4.88	1½	1	1½	1
7	8.10	7½	¾-14	1	2	1½	9/16	5.73	1½	1	1½	1

H	P	LB	LG
1½	2¼	3⅝	4
1½	2¼	3⅝	4
1¼	2⅜	3¾	4½
1¼	2⅝	4¼	4⅞
1¼	2⅝	4¼	4⅞
1½	2⅞	4½	5⅞
1½	3⅞	5	5¾
1⅝	3¼	5⅞	-

Rod End Dimensions

Bore Size	Rod Dia (MM)	A	B -.001 to -.003	C	D	V	W	AB	KK Styles 2,4&6	RD (Max.)	RT	VB	WB
1½	5/8	¾	1.125	¾	½	¼	5/8	10-32	7/16-20	1.972	.141	5/8	1
	1	1⅛	1.500	½	7/8	½	1	—	¾-16	2.472	.313	7/8	1⅜
2	5/8	¾	1.125	¾	½	—	—	10-32	7/16-20	1.972	.141	5/8	1
	1	1⅛	1.500	½	7/8	½	1	¼-28	¾-16	2.472	.313	7/8	1⅜
2½	1⅜	1⅝	2.000	5/8	1⅛	5/8	1¼	—	1-14	2.972	.313	1	1⅝
	5/8	¾	1.125	¾	½	—	—	10-32	7/16-20	1.972	.141	5/8	1
	1	1⅛	1.500	½	7/8	—	—	¼-28	¾-16	2.472	.313	7/8	1⅜
3¼	1⅜	1⅝	2.000	5/8	1⅛	5/8	1¼	¼-28	1-14	2.972	.313	1	1⅝
	1¾	2	2.375	¾	1½	¾	1½	—	1¼-12	3.470	.313	1⅛	1⅞
	1	1⅛	1.500	½	7/8	—	—	¼-28	¾-16	2.472	.313	7/8	1⅜
4	1¾	2	2.375	¾	1½	½	1¼	¼-28	1¼-12	3.470	.313	1⅛	1⅞
	2	2¼	2.625	7/8	1⅞	—	—	¼-28	1½-12	3.720	.313	1⅛	2
	1¾	2	2.375	¾	1½	—	—	¼-28	1¼-12	3.470	.313	1⅛	1⅞
	1⅜	1⅝	2.000	5/8	1⅛	—	—	¼-28	1-14	2.972	.313	1	1⅝
5	2½	3	3.125	1	2⅞	5/8	1⅝	¼-28	1⅞-12	4.252	.313	1¼	2¼
	2	2¼	2.625	7/8	1⅞	—	—	¼-28	1¼-12	3.470	.313	1⅛	1⅞
	1¾	2	2.375	¾	1½	—	—	¼-28	1¼-12	3.470	.313	1⅛	1⅞
	1⅜	1⅝	2.000	5/8	1⅛	—	—	¼-28	1-14	2.972	.313	1	1⅝
	1	1⅛	1.500	½	7/8	—	—	¼-28	¾-16	2.472	.313	7/8	1⅜
	2½	3	3.125	1	2⅞	5/8	1⅝	¼-28	1⅞-12	4.252	.313	1¼	2¼
6	3½	3½	4.250	1	3	5/8	1⅝	¼-28	2½-12	5.252	.313	1¼	2¼
	3	3½	3.750	1	2⅝	—	—	¼-28	2¼-12	4.752	.313	1¼	2¼
	2½	3	3.125	1	2⅞	—	—	¼-28	1⅞-12	4.252	.313	1¼	2¼
	2	2¼	2.625	7/8	1⅞	—	—	¼-28	1½-12	3.720	.313	1⅛	2
	1¾	2	2.375	¾	1½	—	—	¼-28	1¼-12	3.470	.313	1⅛	1⅞
	1⅜	1⅝	2.000	5/8	1⅛	—	—	¼-28	1-14	2.972	.313	1	1⅝
7	4½	4½	5.250	1	3⅞	—	—	5/16-24	3-12	5.939	.610	1¼	2¼
	4	4	4.750	1	3⅞	—	—	5/16-24	3-12	5.939	.610	1¼	2¼
	3½	3½	4.250	1	3	—	—	¼-28	2½-12	5.252	.313	1¼	2¼
	3	3½	3.750	1	2⅝	—	—	¼-28	2¼-12	4.752	.313	1¼	2¼
	2½	3	3.125	1	2⅞	—	—	¼-28	1⅞-12	4.252	.313	1¼	2¼
	2	2¼	2.625	7/8	1⅞	—	—	¼-28	1½-12	3.720	.313	1⅛	2
	1¾	2	2.375	¾	1½	—	—	¼-28	1¼-12	3.470	.313	1⅛	1⅞
	1⅜	1⅝	2.000	5/8	1⅛	—	—	¼-28	1-14	2.972	.313	1	1⅝

Add Stroke

XA	ZA
5⅜	5⅞
5¾	6¼
5⅞	5⅞
5¾	6¼
6	6½
5½	6
5⅞	6⅜
6⅞	6⅞
6⅞	6⅞
7⅞	7⅞
7⅞	8⅞
7½	8¼
6⅞	7⅞
7⅞	7⅞
7⅞	8⅞
7¾	8½
8	8¾
8	8¾
8	8¾
8⅞	9⅞
8⅞	9⅞
8½	9½
8¾	9¾
8¾	9¾
8¾	9¾
8¾	9¾
8⅞	9⅞
8⅞	9⅞
8⅞	9⅞
8⅞	9⅞

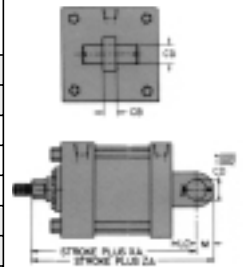

Rear Eye
Model 90-B (NFPA MP3)

** For Style #1 Rod End, 5/8 Rod Dia. — D=7/16". 1" Rod Dia. — D=13/16"

Miller Series A Air Cylinders & Series J Hydraulic Cylinders

Double Rod End

Bolted Bushing Double Rod End

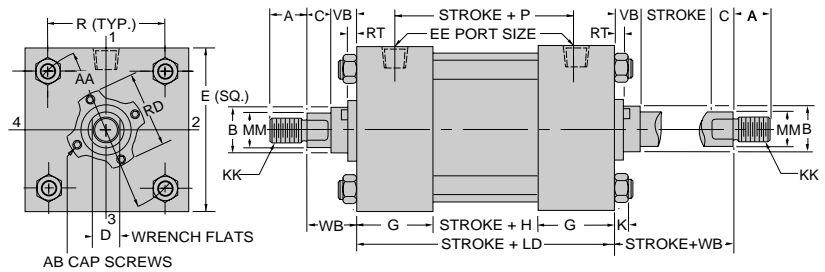
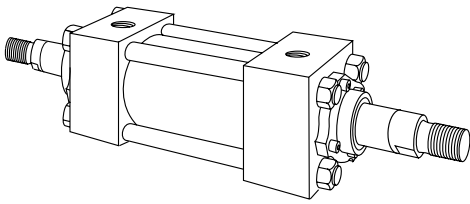

Note: To determine the dimensions for your Double Rod End cylinder:

- Refer to the Single Rod mounting style you are selecting on the preceding pages.
- Select the necessary dimensions which pertain to your mounting style.
- Return to this page and use these dimensions to finish sizing your cylinder.

Note: Double Rod End cylinders have head (G dimensions) at both ends, and LD replaces the LB dimension. On Double Rod End cylinders where the rod end styles differ, be sure to clearly state which rod end is on which cylinder end (port position 1 is standard).

Square Retainer Held Bushing Double Rod End

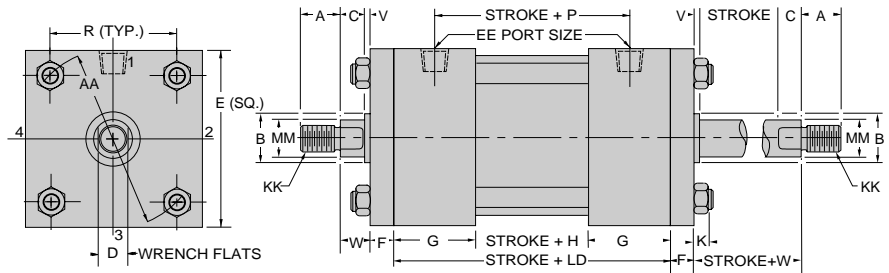
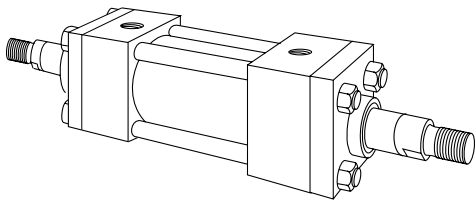

Note: To determine the dimensions for your Double Rod End cylinder:

- Refer to the Single Rod mounting style you are selecting on the preceding pages.
- Select the necessary dimensions which pertain to your mounting style.
- Return to this page and use these dimensions to finish sizing your cylinder.

Note: Double Rod End cylinders have head (G dimensions) at both ends, and LD replaces the LB dimension. On Double Rod End cylinders where the rod end styles differ, be sure to clearly state which rod end is on which cylinder end (port position 1 is standard).

Common Rod End Styles & Dimensions (See page 56 for complete listing of rod end styles.)

Style No. 2-Standard
Threaded on Turndown Section

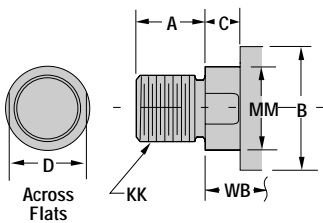

Style No. 4
Short Rod End-Internal Threads

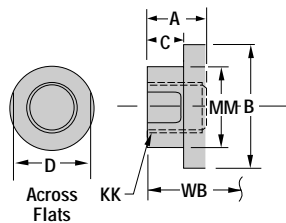

Style No. 6
Studded Rod End

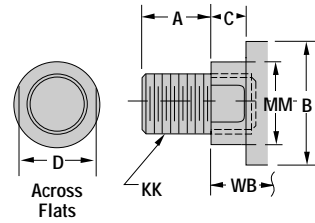

Bore	LD
1½	4⅞
2	4⅞
2½	4¾
3¼	4¾
4	4¾
5	5
6	5½
7	5⅝

Large Bore Air & Hydraulic Cylinders

8" - 20" Bores

Miller Series A Air Cylinders & Series J Hydraulic Cylinders

Tie Rods Extended
8" - 20" Bore Cylinders

Model 52-B (NFPA MX2) Bolted Bushing Tie Rods Extended Cap End

Mounting Dimensions (see tables on opposite page)

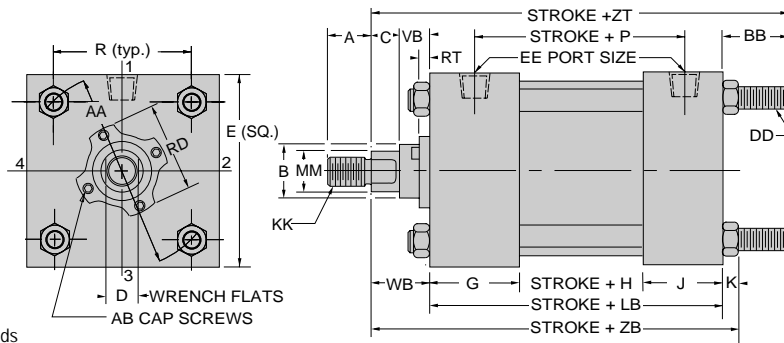
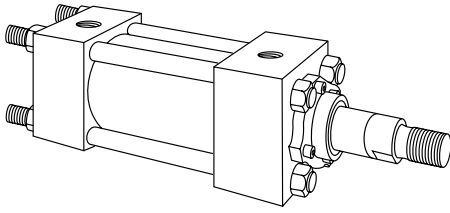

Also Available

Model 50-B No Tie Rods Extended, Model 51-B (NFPA MX1) Tie Rods Extended both ends, Model 53-B (NFPA MX3) Tie Rods Extended head end, Model 54-B (NFPA MX4) two Tie Rods Extended both ends at position #3.
All of the above models can be dimensioned from Model 52-B shown.

Common Rod End Styles & Dimensions (See page 56 for complete listing of rod end styles.)

Style No. 2-Standard Threaded on Turndown Section

Style No. 4 Short Rod End-Internal Threads

Style No. 6 Studded Rod End

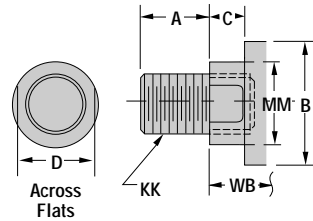
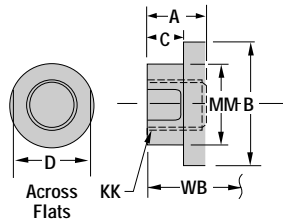
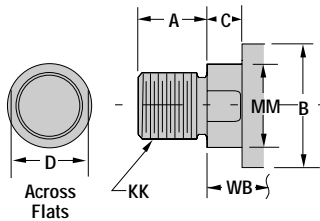

Miller Series A Air Cylinders & Series J Hydraulic Cylinders

Tie Rods Extended
8" – 20" Bore Cylinders

Large Bore A & J Models 50, 51, 52, 53, 54

Bore Size	AA	E	EE	BB	G	J	K	R	DD
8	9.10	8 1/2	3/4 - 14	2 5/16	2	1 1/2	9/16	6.44	5/8 - 18
10	11.20	10 5/8	1-11 1/2	2 11/16	2 1/4	2	11/16	7.92	3/4 - 16
12	13.30	12 3/4	1-11 1/2	2 11/16	2 1/4	2	11/16	9.40	3/4 - 16
14	15.40	14 3/4	1 1/4-11 1/2	3 3/16	2 3/4	2 1/4	13/16	10.90	7/8 - 14
16	17.80	17	1 1/4-11 1/2	3 5/8	2 3/4	2 1/4	7/8	12.58	1 - 14
18	20.00	19	1 1/4-11 1/2	4 1/8	2 3/4	2 1/4	1	14.14	1 1/8 - 12
20	22.30	21	1 1/4-11 1/2	4 1/2	2 3/4	2 1/4	1 1/4	15.77	1 1/4 - 12

† LD Dimension is for double rod end models. See page 40.

Stroke Plus

H	P	LB	LD
1 5/8	3 1/4	5 1/8	5 5/8
2 1/8	4 1/8	6 3/8	6 5/8
2 5/8	4 5/8	6 7/8	7 1/8
3 1/8	5 1/2	8 1/8	8 5/8
2 1/2	4 7/8	7 1/2	8
2 7/8	5 1/4	7 7/8	8 3/8
3 1/4	5 5/8	8 1/4	8 3/4

Rod End Dimensions

Bore Size	Rod Dia (MM)	A	B -.001 to -.003	C	D	AB	KK (Styles 2, 4, 6)	RD (MAX.)	RT	VB	WB
8	1 3/8	1 5/8	2.000	5/8	1 1/8	1/4-28	1-14	2.972	.313	1	1 5/8
	1 3/4	2	2.375	3/4	1 1/2	1/4-28	1 1/4-12	3.470	.313	1 1/8	1 7/8
	2	2 1/4	2.625	7/8	1 11/16	1/4-28	1 1/2-12	3.720	.313	1 1/8	2
	2 1/2	3	3.125	1	2 1/16	1/4-28	1 7/8-12	4.252	.313	1 1/4	2 1/4
	3	3 1/2	3.750	1	2 5/8	1/4-28	2 1/4-12	4.752	.313	1 1/4	2 1/4
	3 1/2	3 1/2	4.250	1	3	1/4-28	2 1/2-12	5.252	.313	1 1/4	2 1/4
	4	4	4.750	1	3 3/8	5/16-24	3-12	5.939	.610	1 1/4	2 1/4
	4 1/2	4 1/2	5.250	1	3 7/8	5/16-24	3 1/4-12	6.439	.610	1 1/4	2 1/4
10	5	5	5.750	1	4 1/4	5/16-24	3 1/2-12	6.939	.610	1 1/4	2 1/4
	5 1/2	5 1/2	6.250	1	4 5/8	5/16-24	4-12	7.439	.610	1 1/4	2 1/4
	1 3/4	2	2.375	3/4	1 1/2	1/4-28	1 1/4-12	3.470	.313	1 1/8	1 7/8
	2	2 1/4	2.625	7/8	1 11/16	1/4-28	1 1/2-12	3.720	.313	1 1/8	2
	2 1/2	3	3.125	1	2 1/16	1/4-28	1 7/8-12	4.252	.313	1 1/4	2 1/4
	3	3 1/2	3.750	1	2 5/8	1/4-28	2 1/4-12	4.752	.313	1 1/4	2 1/4
	3 1/2	3 1/2	4.250	1	3	1/4-28	2 1/2-12	5.252	.313	1 1/4	2 1/4
	4	4	4.750	1	3 3/8	5/16-24	3-12	5.939	.610	1 1/4	2 1/4
12	4 1/2	4 1/2	5.250	1	3 7/8	5/16-24	3 1/4-12	6.439	.610	1 1/4	2 1/4
	5	5	5.750	1	4 1/4	5/16-24	3 1/2-12	6.939	.610	1 1/4	2 1/4
	5 1/2	5 1/2	6.250	1	4 5/8	5/16-24	4-12	7.439	.610	1 1/4	2 1/4
	2	2 1/4	2.625	7/8	1 11/16	1/4-28	1 1/2-12	3.720	.313	1 1/8	2
	2 1/2	3	3.125	1	2 1/16	1/4-28	1 7/8-12	4.252	.313	1 1/4	2 1/4
	3	3 1/2	3.750	1	2 5/8	1/4-28	2 1/4-12	4.752	.313	1 1/4	2 1/4
	3 1/2	3 1/2	4.250	1	3	1/4-28	2 1/2-12	5.252	.313	1 1/4	2 1/4
	4	4	4.750	1	3 3/8	5/16-24	3-12	5.939	.610	1 1/4	2 1/4
14	4 1/2	4 1/2	5.250	1	3 7/8	5/16-24	3 1/4-12	6.439	.610	1 1/4	2 1/4
	5	5	5.750	1	4 1/4	5/16-24	3 1/2-12	6.939	.610	1 1/4	2 1/4
	5 1/2	5 1/2	6.250	1	4 5/8	5/16-24	4-12	7.439	.610	1 1/4	2 1/4
	2 1/2	3	3.125	1	2 1/16	1/4-28	1 7/8-12	4.252	.313	1 1/4	2 1/4
	3	3 1/2	3.750	1	2 5/8	1/4-28	2 1/4-12	4.752	.313	1 1/4	2 1/4
	3 1/2	3 1/2	4.250	1	3	1/4-28	2 1/2-12	5.252	.313	1 1/4	2 1/4
	4	4	4.750	1	3 3/8	5/16-24	3-12	5.939	.610	1 1/4	2 1/4
	4 1/2	4 1/2	5.250	1	3 7/8	5/16-24	3 1/4-12	6.439	.610	1 1/4	2 1/4
16	5	5	5.750	1	4 1/4	5/16-24	3 1/2-12	6.939	.610	1 1/4	2 1/4
	5 1/2	5 1/2	6.250	1	4 5/8	5/16-24	4-12	7.439	.610	1 1/4	2 1/4
	2 1/2	3	3.125	1	2 1/16	1/4-28	1 7/8-12	4.252	.313	1 1/4	2 1/4
	3	3 1/2	3.750	1	2 5/8	1/4-28	2 1/4-12	4.752	.313	1 1/4	2 1/4
	3 1/2	3 1/2	4.250	1	3	1/4-28	2 1/2-12	5.252	.313	1 1/4	2 1/4
	4	4	4.750	1	3 3/8	5/16-24	3-12	5.939	.610	1 1/4	2 1/4
	4 1/2	4 1/2	5.250	1	3 7/8	5/16-24	3 1/4-12	6.439	.610	1 1/4	2 1/4
	5	5	5.750	1	4 1/4	5/16-24	3 1/2-12	6.939	.610	1 1/4	2 1/4
18	5 1/2	5 1/2	6.250	1	4 5/8	5/16-24	4-12	7.439	.610	1 1/4	2 1/4
	3	3 1/2	3.750	1	2 5/8	1/4-28	2 1/4-12	4.752	.313	1 1/4	2 1/4
	3 1/2	3 1/2	4.250	1	3	1/4-28	2 1/2-12	5.252	.313	1 1/4	2 1/4
	4	4	4.750	1	3 3/8	5/16-24	3-12	5.939	.610	1 1/4	2 1/4
	4 1/2	4 1/2	5.250	1	3 7/8	5/16-24	3 1/4-12	6.439	.610	1 1/4	2 1/4
	5	5	5.750	1	4 1/4	5/16-24	3 1/2-12	6.939	.610	1 1/4	2 1/4
	5 1/2	5 1/2	6.250	1	4 5/8	5/16-24	4-12	7.439	.610	1 1/4	2 1/4
	20	3	3 1/2	3.750	1	2 5/8	1/4-28	2 1/4-12	4.752	.313	1 1/4
3 1/2		3 1/2	4.250	1	3	1/4-28	2 1/2-12	5.252	.313	1 1/4	2 1/4
4		4	4.750	1	3 3/8	5/16-24	3-12	5.939	.610	1 1/4	2 1/4
4 1/2		4 1/2	5.250	1	3 7/8	5/16-24	3 1/4-12	6.439	.610	1 1/4	2 1/4
5		5	5.750	1	4 1/4	5/16-24	3 1/2-12	6.939	.610	1 1/4	2 1/4
5 1/2		5 1/2	6.250	1	4 5/8	5/16-24	4-12	7.439	.610	1 1/4	2 1/4

Add Stroke

ZT	ZB
9 1/16	7 5/16
9 5/16	7 7/16
9 7/16	7 11/16
9 11/16	7 15/16
9 11/16	7 15/16
9 11/16	7 15/16
9 11/16	7 15/16
9 11/16	7 15/16
9 11/16	7 15/16
9 11/16	7 15/16
10 15/16	8 15/16
11 1/16	9 1/16
11 5/16	9 5/16
11 9/16	9 9/16
11 9/16	9 9/16
11 9/16	9 9/16
11 9/16	9 9/16
11 9/16	9 9/16
11 9/16	9 9/16
11 9/16	9 9/16
11 13/16	9 13/16
11 13/16	9 13/16
11 13/16	9 13/16
11 13/16	9 13/16
11 13/16	9 13/16
11 13/16	9 13/16
11 13/16	9 13/16
11 13/16	9 13/16
13 9/16	11 3/16
13 9/16	11 3/16
13 9/16	11 3/16
13 9/16	11 3/16
13 9/16	11 3/16
13 9/16	11 3/16
13 9/16	11 3/16
13 9/16	11 3/16
13 9/16	11 3/16
13 3/8	10 5/8
13 3/8	10 5/8
13 3/8	10 5/8
13 3/8	10 5/8
13 3/8	10 5/8
13 3/8	10 5/8
14 1/4	11 1/8
14 1/4	11 1/8
14 1/4	11 1/8
14 1/4	11 1/8
14 1/4	11 1/8
15	11 3/4
15	11 3/4
15	11 3/4
15	11 3/4
15	11 3/4
15	11 3/4

Tie Rod Mounts

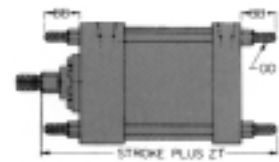

Tie Rods extended both ends
Model 51-B (NFPA MX1)

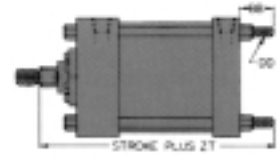

Tie Rods extended cap end
Model 52-B (NFPA MX2)

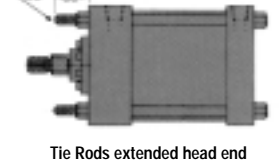

Tie Rods extended head end
Model 53-B (NFPA MX3)

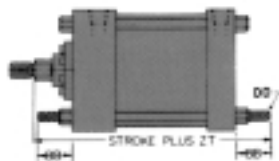

Two Tie Rods extended both ends
Model 54-B (NFPA MX4)

NOTE: For overall length on double rod-end cylinders, use overall length common dimension "Stroke plus LD" instead of "Stroke plus ZT" shown here, and add appropriate mounting dimensions.

Miller Series A Air Cylinders & Series J Hydraulic Cylinders

Square Head/Cap
8" – 20" Bore Cylinders

Model 63-B (NFPA ME3) Bolted Bushing Square Head

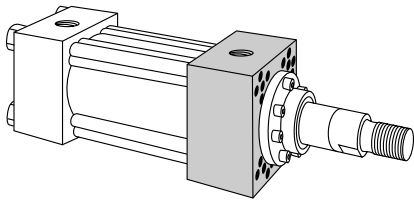

Mounting Dimensions (see tables on opposite page)

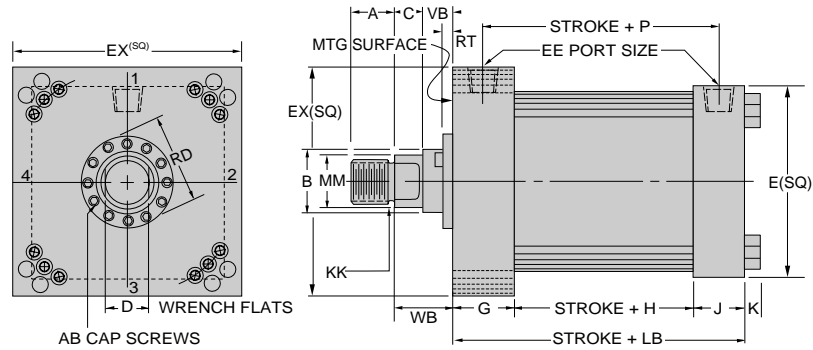

Model 64-B (NFPA ME4) Bolted Bushing Square Cap

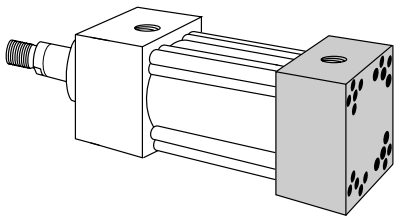

Mounting Dimensions (see tables on opposite page)

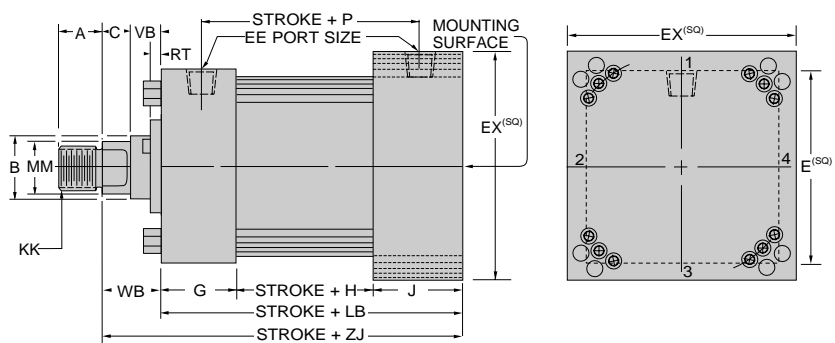

Common Rod End Styles & Dimensions (See page 56 for complete listing of rod end styles.)

Style No. 2-Standard
Threaded on Turndown Section

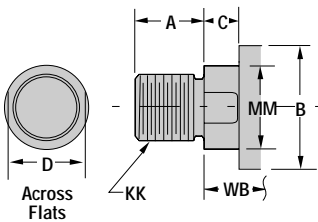

Style No. 4
Short Rod End-Internal Threads

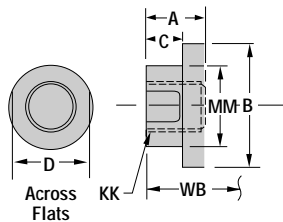

Style No. 6
Studded Rod End

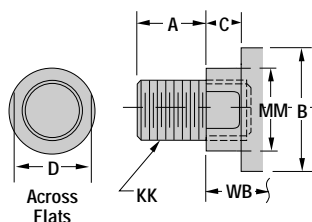

Miller Series A Air Cylinders & Series J Hydraulic Cylinders

Square Head/Cap 8" – 20" Bore Cylinders

Large Bore A & J Models 63 & 64

Bore Size	AA	E	EE	EB	G	J	K	R	TE
8	9.10	8 1/2	3/4 - 14	5/8	2	1 1/2	9/16	6.44	7.57
10	11.20	10 5/8	1-11 1/2	3/4	2 1/4	2	11/16	7.92	9.40
12	13.30	12 3/4	1-11 1/2	3/4	2 1/4	2	11/16	9.40	11.10
14	15.40	14 3/4	1 1/4-11 1/2	7/8	2 3/4	2 1/4	13/16	10.90	12.87
16	17.80	17	1 1/4-11 1/2	1	2 3/4	2 1/4	7/8	12.58	14.85
18	20.00	19	1 1/4-11 1/2	1 1/8	2 3/4	2 1/4	1	14.14	16.69
20	22.30	21	1 1/4-11 1/2	1 1/4	2 3/4	2 1/4	1 1/4	15.77	18.46

Stroke Plus

H	P	LB	LD
1 5/8	3 1/4	5 1/8	5 5/8
2 1/8	4 1/8	6 3/8	6 5/8
2 5/8	4 5/8	6 7/8	7 1/8
3 1/8	5 1/2	8 1/8	8 5/8
2 1/2	4 7/8	7 1/2	8
2 7/8	5 1/4	7 7/8	8 3/8
3 1/4	5 5/8	8 1/4	8 3/4

† LD Dimension is for double rod end models. See page 40.

Rod End Dimensions

Bore Size	Rod Dia (MM)	A	B -.001 to -.003	C	D	AB	KK (Styles 2, 4, 6)	RD MAX.	RT	VB	WB	
8	1 3/8	1 5/8	2.000	5/8	1 1/8	1/4-28	1-14	2.972	.313	1	1 5/8	
	1 3/4	2	2.375	3/4	1 1/2	1/4-28	1 1/4-12	3.470	.313	1 1/8	1 7/8	
	2	2 1/4	2.625	7/8	1 11/16	1/4-28	1 1/2-12	3.720	.313	1 1/8	2	
	2 1/2	3	3.125	1	2 1/16	1/4-28	1 7/8-12	4.252	.313	1 1/4	2 1/4	
	3	3 1/2	3.750	1	2 5/8	1/4-28	2 1/4-12	4.752	.313	1 1/4	2 1/4	
	3 1/2	3 3/2	4.250	1	3	1/4-28	2 1/2-12	5.252	.313	1 1/4	2 1/4	
	4	4	4.750	1	3 3/8	5/16-24	3-12	5.939	.610	1 1/4	2 1/4	
	4 1/2	4 1/2	5.250	1	3 7/8	5/16-24	3 1/4-12	6.439	.610	1 1/4	2 1/4	
	5	5	5.750	1	4 1/4	5/16-24	3 1/2-12	6.939	.610	1 1/4	2 1/4	
	5 1/2	5 1/2	6.250	1	4 5/8	5/16-24	4-12	7.439	.610	1 1/4	2 1/4	
10	1 3/4	2	2.375	3/4	1 1/2	1/4-28	1 1/4-12	3.470	.313	1 1/8	1 7/8	
	2	2 1/4	2.625	7/8	1 11/16	1/4-28	1 1/2-12	3.720	.313	1 1/8	2	
	2 1/2	3	3.125	1	2 1/16	1/4-28	1 7/8-12	4.252	.313	1 1/4	2 1/4	
	3	3 1/2	3.750	1	2 5/8	1/4-28	2 1/4-12	4.752	.313	1 1/4	2 1/4	
	3 1/2	3 1/2	4.250	1	3	1/4-28	2 1/2-12	5.252	.313	1 1/4	2 1/4	
	4	4	4.750	1	3 3/8	5/16-24	3-12	5.939	.610	1 1/4	2 1/4	
	4 1/2	4 1/2	5.250	1	3 7/8	5/16-24	3 1/4-12	6.439	.610	1 1/4	2 1/4	
	5	5	5.750	1	4 1/4	5/16-24	3 1/2-12	6.939	.610	1 1/4	2 1/4	
	5 1/2	5 1/2	6.250	1	4 5/8	5/16-24	4-12	7.439	.610	1 1/4	2 1/4	
	12	2	2 1/4	2.625	7/8	1 11/16	1/4-28	1 1/2-12	3.720	.313	1 1/8	2
2 1/2		3	3.125	1	2 1/16	1/4-28	1 7/8-12	4.252	.313	1 1/4	2 1/4	
3		3 1/2	3.750	1	2 5/8	1/4-28	2 1/4-12	4.752	.313	1 1/4	2 1/4	
3 1/2		3 1/2	4.250	1	3	1/4-28	2 1/2-12	5.252	.313	1 1/4	2 1/4	
4		4	4.750	1	3 3/8	5/16-24	3-12	5.939	.610	1 1/4	2 1/4	
4 1/2		4 1/2	5.250	1	3 7/8	5/16-24	3 1/4-12	6.439	.610	1 1/4	2 1/4	
5		5	5.750	1	4 1/4	5/16-24	3 1/2-12	6.939	.610	1 1/4	2 1/4	
5 1/2		5 1/2	6.250	1	4 5/8	5/16-24	4-12	7.439	.610	1 1/4	2 1/4	
14		2 1/2	3	3.125	1	2 1/16	1/4-28	1 7/8-12	4.252	.313	1 1/4	2 1/4
		3	3 1/2	3.750	1	2 5/8	1/4-28	2 1/4-12	4.752	.313	1 1/4	2 1/4
	3 1/2	3 1/2	4.250	1	3	1/4-28	2 1/2-12	5.252	.313	1 1/4	2 1/4	
	4	4	4.750	1	3 3/8	5/16-24	3-12	5.939	.610	1 1/4	2 1/4	
	4 1/2	4 1/2	5.250	1	3 7/8	5/16-24	3 1/4-12	6.439	.610	1 1/4	2 1/4	
	5	5	5.750	1	4 1/4	5/16-24	3 1/2-12	6.939	.610	1 1/4	2 1/4	
	5 1/2	5 1/2	6.250	1	4 5/8	5/16-24	4-12	7.439	.610	1 1/4	2 1/4	
	16	2 1/2	3	3.125	1	2 1/16	1/4-28	1 7/8-12	4.252	.313	1 1/4	2 1/4
		3	3 1/2	3.750	1	2 5/8	1/4-28	2 1/4-12	4.752	.313	1 1/4	2 1/4
		3 1/2	3 1/2	4.250	1	3	1/4-28	2 1/2-12	5.252	.313	1 1/4	2 1/4
4		4	4.750	1	3 3/8	5/16-24	3-12	5.939	.610	1 1/4	2 1/4	
4 1/2		4 1/2	5.250	1	3 7/8	5/16-24	3 1/4-12	6.439	.610	1 1/4	2 1/4	
5		5	5.750	1	4 1/4	5/16-24	3 1/2-12	6.939	.610	1 1/4	2 1/4	
5 1/2		5 1/2	6.250	1	4 5/8	5/16-24	4-12	7.439	.610	1 1/4	2 1/4	
18		3	3 1/2	3.750	1	2 5/8	1/4-28	2 1/4-12	4.752	.313	1 1/4	2 1/4
		3 1/2	3 1/2	4.250	1	3	1/4-28	2 1/2-12	5.252	.313	1 1/4	2 1/4
		4	4	4.750	1	3 3/8	5/16-24	3-12	5.939	.610	1 1/4	2 1/4
	4 1/2	4 1/2	5.250	1	3 7/8	5/16-24	3 1/4-12	6.439	.610	1 1/4	2 1/4	
	5	5	5.750	1	4 1/4	5/16-24	3 1/2-12	6.939	.610	1 1/4	2 1/4	
	5 1/2	5 1/2	6.250	1	4 5/8	5/16-24	4-12	7.439	.610	1 1/4	2 1/4	
	20	3	3 1/2	3.750	1	2 5/8	1/4-28	2 1/4-12	4.752	.313	1 1/4	2 1/4
		3 1/2	3 1/2	4.250	1	3	1/4-28	2 1/2-12	5.252	.313	1 1/4	2 1/4
		4	4	4.750	1	3 3/8	5/16-24	3-12	5.939	.610	1 1/4	2 1/4
		4 1/2	4 1/2	5.250	1	3 7/8	5/16-24	3 1/4-12	6.439	.610	1 1/4	2 1/4
5		5	5.750	1	4 1/4	5/16-24	3 1/2-12	6.939	.610	1 1/4	2 1/4	
5 1/2		5 1/2	6.250	1	4 5/8	5/16-24	4-12	7.439	.610	1 1/4	2 1/4	

Add Stroke

ZB	ZJ
7 5/16	6 3/4
7 9/16	7
7 11/16	7 1/8
7 15/16	7 3/8
7 15/16	7 3/8
7 15/16	7 3/8
7 15/16	7 3/8
7 15/16	7 3/8
7 15/16	7 3/8
8 15/16	8 1/4
9 1/16	8 3/8
9 5/16	8 5/8
9 5/16	8 5/8
9 5/16	8 5/8
9 5/16	8 5/8
9 5/16	8 5/8
9 5/16	8 5/8
9 9/16	8 7/8
9 13/16	9 1/8
9 13/16	9 1/8
9 13/16	9 1/8
9 13/16	9 1/8
9 13/16	9 1/8
11 3/16	10 3/8
11 3/16	10 3/8
11 3/16	10 3/8
11 3/16	10 3/8
11 3/16	10 3/8
11 3/16	10 3/8
11 3/16	10 3/8
10 5/8	9 3/4
10 5/8	9 3/4
10 5/8	9 3/4
10 5/8	9 3/4
10 5/8	9 3/4
11 1/8	10 1/8
11 1/8	10 1/8
11 1/8	10 1/8
11 1/8	10 1/8
11 1/8	10 1/8
11 3/4	10 1/2
11 3/4	10 1/2
11 3/4	10 1/2
11 3/4	10 1/2
11 3/4	10 1/2

Square Head & Cap Mounts

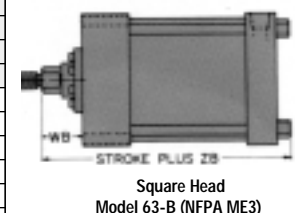
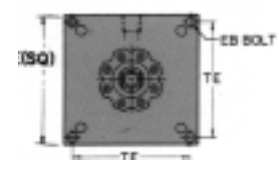

Square Head
Model 63-B (NFPA ME3)

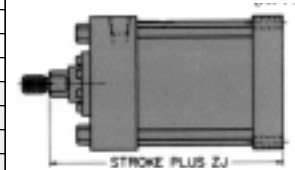
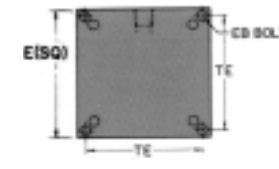

Square Cap
Model 64-B (NFPA ME4)

NOTE: Socket head screws should be used for mounting 8" bore cylinders. Mounting holes are 1/16" larger than bolt sizes (EB) shown.

Miller Series A Air Cylinders & Series J Hydraulic Cylinders

Side Lug
8" – 20" Bore Cylinders

Model 72-B (NFPA MS2) Bolted Bushing Side Lug

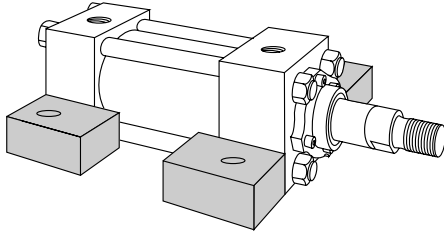

Mounting Dimensions (See tables on opposite page)

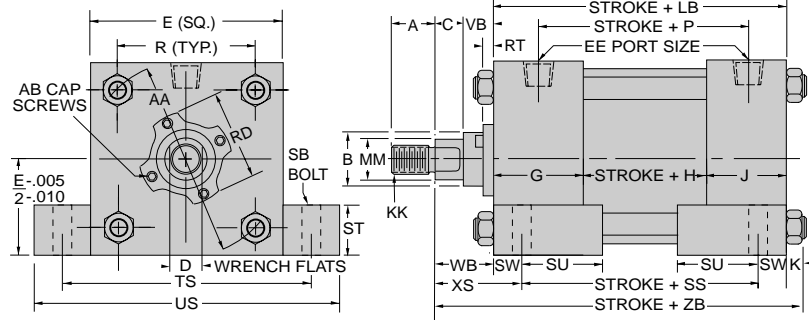

Note: Lugs should be blocked, or a "K" retainer should be mounted on the appropriate end to absorb hydraulic or mechanical shock. Bolts should not carry shear load.

Model 73-B (NFPA MS3) Bolted Bushing Centerline Lug

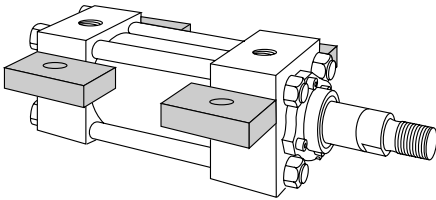

Mounting Dimensions (See tables on opposite page)

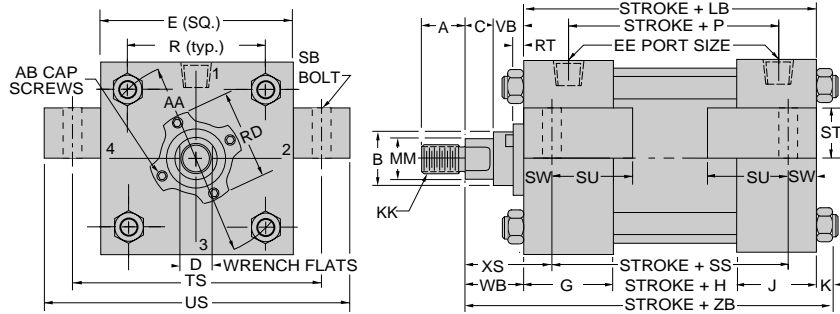

Note: Lugs should be blocked, or a "K" retainer should be mounted on the appropriate end to absorb hydraulic or mechanical shock. Bolts should not carry shear load.

Common Rod End Styles & Dimensions (See page 56 for complete listing of rod end styles.)

Style No. 2-Standard
Threaded on Turndown Section

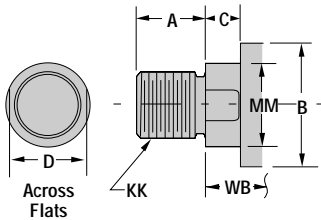

Style No. 4
Short Rod End-Internal Threads

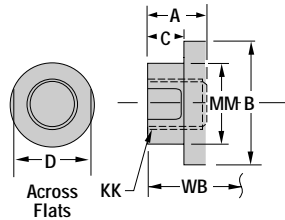

Style No. 6
Studded Rod End

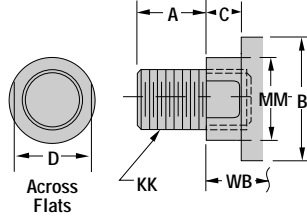

Pressure Limitation For J Series Model *72 Side Lug

BORE	PRESSURE LIMITATIONS	
	MODERATE PSI	SEVERE PSI
8	520	310
10	590	350
12	530	320
14	480	290
16	500	300
18	430	260
20	350	210

* NOTE: Lugs should be blocked or pinned on the appropriate end to absorb hydraulic or mechanical shock. Mounting holes are 1/16" larger than the bolt sizes (SB) shown. For overall length on double rod-end cylinders, use common dimension "Stroke plus LD" instead of "Stroke plus SS" shown here, and subtract "SW" from each end.

Miller Series A Air Cylinders & Series J Hydraulic Cylinders

Side Tapped & End Lug 8" - 20" Bore Cylinders

Model 74-B (NFPA MS4) Bolted Bushing Side Tapped

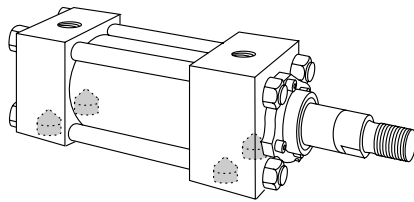

Note: A "K" retainer should be mounted on the appropriate end to absorb hydraulic or mechanical shock. Bolts should not carry shear load.

Mounting Dimensions (See tables on opposite page)

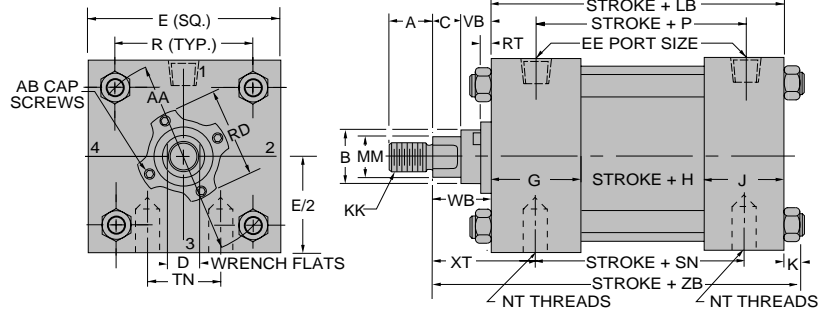

Model 77-B (NFPA MS7) Bolted Bushing End Lug

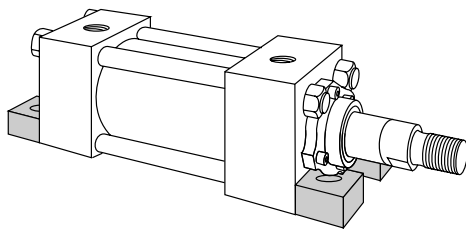

Note: Mounting bolts should not carry shear load. Lugs should be blocked or a "K" retainer should be mounted on the appropriate end to absorb hydraulic or mechanical shock.

Mounting Dimensions (See tables on opposite page)

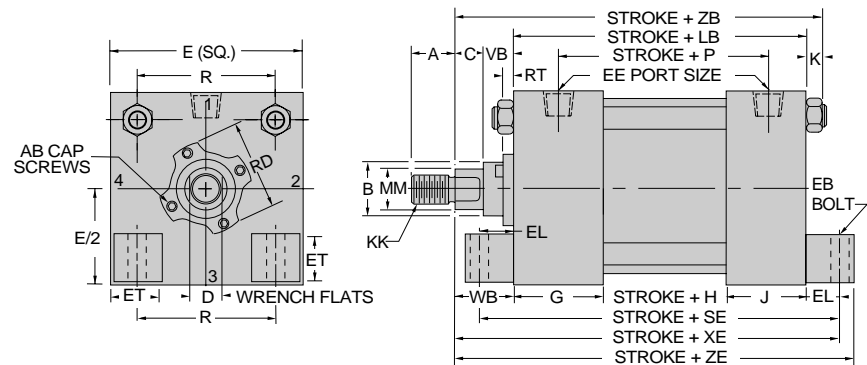

Common Rod End Styles & Dimensions (See page 56 for complete listing of rod end styles.)

Style No. 2-Standard Threaded on Turndown Section

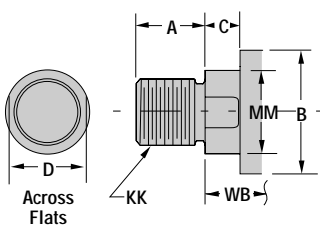

Style No. 4 Short Rod End-Internal Threads

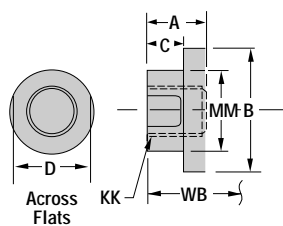

Style No. 6 Studded Rod End

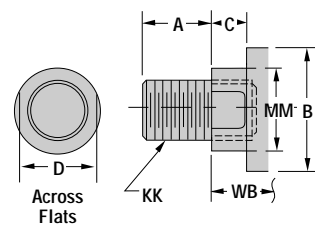

Pressure Limitations For J Series Model *74 Side Tapped & Model *77 End Lug

Pressure Limitations For Model *74 Side Tapped

BORE	PRESSURE LIMITATIONS	
	MODERATE PSI	SEVERE PSI
8	500	300
10	500	300
12	470	280
14	370	220
16	190	110
18	120	70
20	80	50

* NOTE: Cylinder should be keyed to prevent shifting.

Pressure Limitations For Model *77 End Lug

BORE	PRESSURE LIMITATIONS	
	MODERATE PSI	SEVERE PSI
8	500	300
10	500	300
12	470	280
14	370	220
16	190	110
18	120	80
20	80	50

* NOTE: A "K" retainer should be mounted on the appropriate end to absorb hydraulic or mechanical shock. Mounting holes are 1/16" larger than bolt sizes (SB) shown.

Miller Series A Air Cylinders & Series J Hydraulic Cylinders

Trunnion/Head End
8" - 20" Bore Cylinders

Model 81-B (NFPA MT1) Bolted Bushing Trunnion Head End

Mounting Dimensions (See tables on opposite page)

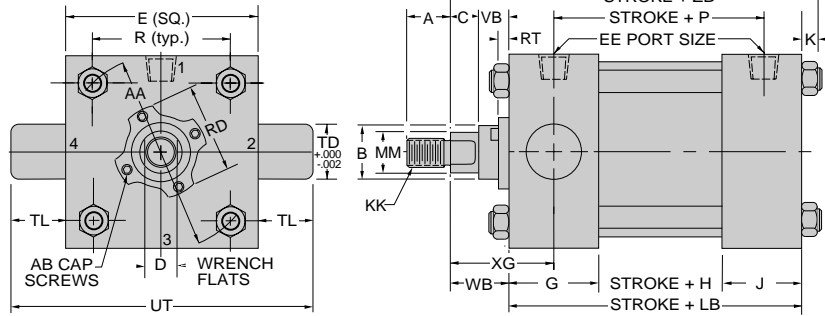
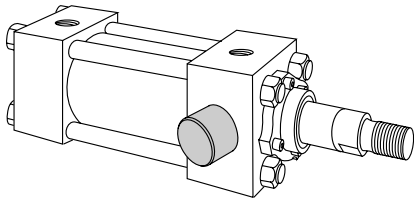

Note: Hard chrome-plated pins designed for shear, (not bending) loads.

Model 82-B (NFPA MT2) Bolted Bushing Trunnion Cap End

Mounting Dimensions (See tables on opposite page)

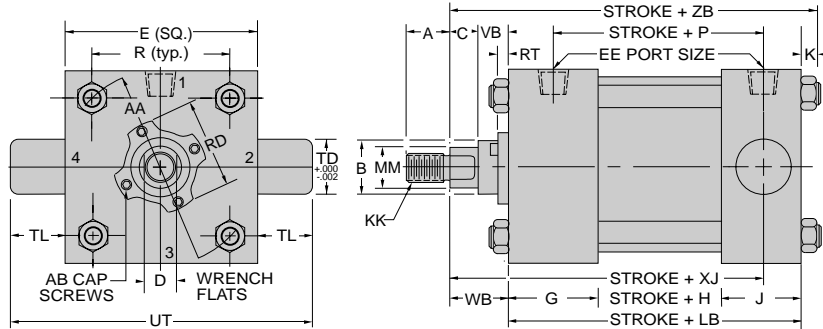
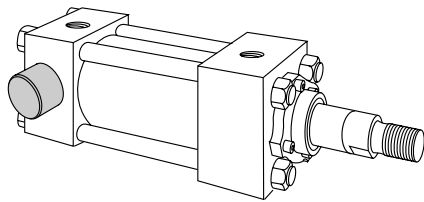

Note: Hard chrome-plated pins designed for shear, (not bending) loads.

Common Rod End Styles & Dimensions (See page 56 for complete listing of rod end styles.)

Style No. 2-Standard
Threaded on Turndown Section

Style No. 4
Short Rod End-Internal Threads

Style No. 6
Studded Rod End

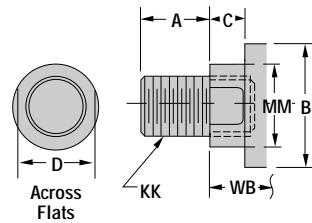
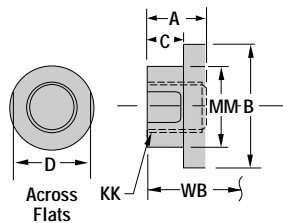
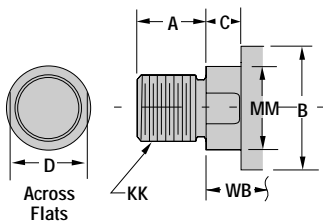

Pressure Limitations For J Series Model 81 & 82 Trunnion Mounts

BORE	PRESSURE LIMITATIONS	
	MODERATE PSI	SEVERE PSI
8	580	350
10	600	360
12	420	250
14	370	220
16	180	110
18	220	130
20	180	110

Note: Pins are designed for shear (not bending) loads.

* Note: Minimum "XI" dimension values shown apply only to the standard rod diameter. When oversized rods are used, minimum "XI" dimensions are increased by the difference between the "WB" dimension for the oversized rod and the "WB" dimension for the standard rod diameter.

** Note: Consult Miller Fluid Power's Engineering Department for shorter stroke requirements.

Miller Series A Air Cylinders & Series J Hydraulic Cylinders

Intermediate Trunnion
8" – 14" Bore Cylinders

Model 89-B (NFPA MT4) Bolted Bushing Intermediate Trunnion

Mounting Dimensions (See tables on opposite page)

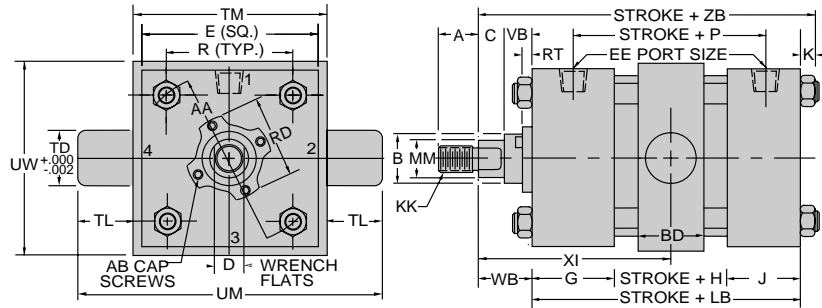
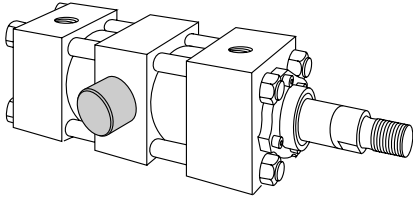

Note: Hard chrome-plated pins designed for shear, (not bending) loads.
Specify dimension "XI" when ordering.

Common Rod End Styles & Dimensions (See page 56 for complete listing of rod end styles.)

Style No. 2-Standard
Threaded on Turndown Section

Style No. 4
Short Rod End-Internal Threads

Style No. 6
Studded Rod End

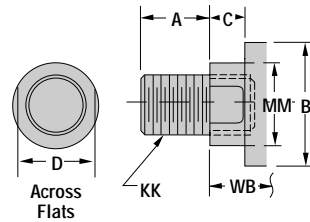
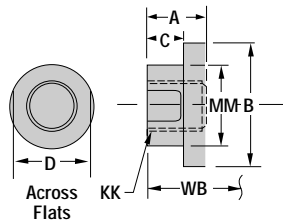
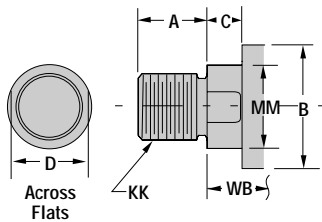

Pressure Limitations For Model 89 Trunnion Mounts

BORE	MOD.	SEVERE	*XI	MIN.
	PSI	PSI	(MIN.)	STRK**
8	500	300	5 ¹ / ₈	19 ³ / ₈
10	440	260	5 ⁷ / ₈	27 ³ / ₈
12	310	180	6 ³ / ₁₆	1 ¹ / ₄
14	330	190	7 ³ / ₈	1 ⁵ / ₈

Note: Pins are designed for shear, (not bending) loads.

* **Note:** Minimum "XI" dimension values shown apply only to the standard rod diameter. When oversized rods are used, minimum "XI" dimensions are increased by the difference between the "WB" dimension for the oversized rod and the "WB" dimension for the standard rod diameter. For Model 89, specify dimension "XI" when ordering.

** **Note:** Consult Miller Fluid Power's Engineering Department for shorter stroke requirements.

Miller Series A Air Cylinders & Series J Hydraulic Cylinders

Intermediate Trunnion
8" - 14" Bore Cylinders

Large Bore A & J Models 81, 82 & 89
(Model 89: 8"-14" bores only)

Stroke Plus

Bore Size	AA	E	EE	BD	G	J	K	R	TD	TL	TM	UM	UT	UW
8	9.10	8 ^{1/2}	3 ^{3/4} -14	3	2	1 ^{1/2}	9 ^{9/16}	6.44	1 ^{3/8}	1 ^{3/8}	9 ^{3/4}	12 ^{1/2}	11 ^{1/4}	9 ^{5/8}
10	11.20	10 ^{5/8}	1-11 ^{1/2}	3 ^{1/2}	2 ^{1/4}	2	1 ^{1/16}	7.92	1 ^{3/4}	1 ^{3/4}	12	15 ^{1/2}	14 ^{1/8}	11 ^{7/8}
12	13.30	12 ^{3/4}	1-11 ^{1/2}	3 ^{7/8}	2 ^{1/4}	2	1 ^{1/16}	9.40	1 ^{3/4}	1 ^{3/4}	14	17 ^{1/2}	16 ^{1/4}	13 ^{7/8}
14	15.40	14 ^{3/4}	1 ^{1/4} -11 ^{1/2}	4 ^{3/4}	2 ^{3/4}	2 ^{1/4}	1 ^{3/16}	10.90	2	2	16 ^{1/4}	20 ^{1/4}	18 ^{3/4}	16 ^{1/8}

H	P	LB	[†] LD
1 ^{5/8}	3 ^{1/4}	5 ^{1/8}	5 ^{5/8}
2 ^{1/8}	4 ^{1/8}	6 ^{3/8}	6 ^{5/8}
2 ^{5/8}	4 ^{5/8}	6 ^{7/8}	7 ^{1/8}
3 ^{1/8}	5 ^{1/2}	8 ^{1/8}	8 ^{5/8}

[†] LD Dimension is for double rod end models. See page 40.

Rod End Dimensions

Bore Size	Rod Dia (MM)	A	B -.001 to -.003	C	D	AB	KK (Styles 2, 4, 6)	RD (MAX.)	RT	VB	WB
8	1 ^{3/8}	1 ^{5/8}	2.000	5/8	1 ^{1/8}	1/4-28	1-14	2.972	.313	1	1 ^{5/8}
	1 ^{3/4}	2	2.375	3/4	1 ^{1/2}	1/4-28	1 ^{1/4} -12	3.470	.313	1 ^{1/8}	1 ^{7/8}
	2	2 ^{1/4}	2.625	7/8	1 ^{11/16}	1/4-28	1 ^{1/2} -12	3.720	.313	1 ^{1/8}	2
	2 ^{1/2}	3	3.125	1	2 ^{1/16}	1/4-28	1 ^{7/8} -12	4.252	.313	1 ^{1/4}	2 ^{1/4}
	3	3 ^{1/2}	3.750	1	2 ^{5/8}	1/4-28	2 ^{1/4} -12	4.752	.313	1 ^{1/4}	2 ^{1/4}
	3 ^{1/2}	3 ^{1/2}	4.250	1	3	1/4-28	2 ^{1/2} -12	5.252	.313	1 ^{1/4}	2 ^{1/4}
	4	4	4.750	1	3 ^{3/8}	5/16-24	3-12	5.939	.610	1 ^{1/4}	2 ^{1/4}
	4 ^{1/2}	4 ^{1/2}	5.250	1	3 ^{7/8}	5/16-24	3 ^{1/4} -12	6.439	.610	1 ^{1/4}	2 ^{1/4}
	5	5	5.750	1	4 ^{1/4}	5/16-24	3 ^{1/2} -12	6.939	.610	1 ^{1/4}	2 ^{1/4}
10	5 ^{1/2}	5 ^{1/2}	6.250	1	4 ^{5/8}	5/16-24	4-12	7.439	.610	1 ^{1/4}	2 ^{1/4}
	1 ^{3/4}	2	2.375	3/4	1 ^{1/2}	1/4-28	1 ^{1/4} -12	3.470	.313	1 ^{1/8}	1 ^{7/8}
	2	2 ^{1/4}	2.625	7/8	1 ^{11/16}	1/4-28	1 ^{1/2} -12	3.720	.313	1 ^{1/8}	2
	2 ^{1/2}	3	3.125	1	2 ^{1/16}	1/4-28	1 ^{7/8} -12	4.252	.313	1 ^{1/4}	2 ^{1/4}
	3	3 ^{1/2}	3.750	1	2 ^{5/8}	1/4-28	2 ^{1/4} -12	4.752	.313	1 ^{1/4}	2 ^{1/4}
	3 ^{1/2}	3 ^{1/2}	4.250	1	3	1/4-28	2 ^{1/2} -12	5.252	.313	1 ^{1/4}	2 ^{1/4}
	4	4	4.750	1	3 ^{3/8}	5/16-24	3-12	5.939	.610	1 ^{1/4}	2 ^{1/4}
	4 ^{1/2}	4 ^{1/2}	5.250	1	3 ^{7/8}	5/16-24	3 ^{1/4} -12	6.439	.610	1 ^{1/4}	2 ^{1/4}
	5	5	5.750	1	4 ^{1/4}	5/16-24	3 ^{1/2} -12	6.939	.610	1 ^{1/4}	2 ^{1/4}
12	5 ^{1/2}	5 ^{1/2}	6.250	1	4 ^{5/8}	5/16-24	4-12	7.439	.610	1 ^{1/4}	2 ^{1/4}
	2	2 ^{1/4}	2.625	7/8	1 ^{11/16}	1/4-28	1 ^{1/2} -12	3.720	.313	1 ^{1/8}	2
	2 ^{1/2}	3	3.125	1	2 ^{1/16}	1/4-28	1 ^{7/8} -12	4.252	.313	1 ^{1/4}	2 ^{1/4}
	3	3 ^{1/2}	3.750	1	2 ^{5/8}	1/4-28	2 ^{1/4} -12	4.752	.313	1 ^{1/4}	2 ^{1/4}
	3 ^{1/2}	3 ^{1/2}	4.250	1	3	1/4-28	2 ^{1/2} -12	5.252	.313	1 ^{1/4}	2 ^{1/4}
	4	4	4.750	1	3 ^{3/8}	5/16-24	3-12	5.939	.610	1 ^{1/4}	2 ^{1/4}
	4 ^{1/2}	4 ^{1/2}	5.250	1	3 ^{7/8}	5/16-24	3 ^{1/4} -12	6.439	.610	1 ^{1/4}	2 ^{1/4}
	5	5	5.750	1	4 ^{1/4}	5/16-24	3 ^{1/2} -12	6.939	.610	1 ^{1/4}	2 ^{1/4}
	5 ^{1/2}	5 ^{1/2}	6.250	1	4 ^{5/8}	5/16-24	4-12	7.439	.610	1 ^{1/4}	2 ^{1/4}
14	2 ^{1/2}	3	3.125	1	2 ^{1/16}	1/4-28	1 ^{7/8} -12	4.252	.313	1 ^{1/4}	2 ^{1/4}
	3	3 ^{1/2}	3.750	1	2 ^{5/8}	1/4-28	2 ^{1/4} -12	4.752	.313	1 ^{1/4}	2 ^{1/4}
	3 ^{1/2}	3 ^{1/2}	4.250	1	3	1/4-28	2 ^{1/2} -12	5.252	.313	1 ^{1/4}	2 ^{1/4}
	4	4	4.750	1	3 ^{3/8}	5/16-24	3-12	5.939	.610	1 ^{1/4}	2 ^{1/4}
	4 ^{1/2}	4 ^{1/2}	5.250	1	3 ^{7/8}	5/16-24	3 ^{1/4} -12	6.439	.610	1 ^{1/4}	2 ^{1/4}
	5	5	5.750	1	4 ^{1/4}	5/16-24	3 ^{1/2} -12	6.939	.610	1 ^{1/4}	2 ^{1/4}
	5 ^{1/2}	5 ^{1/2}	6.250	1	4 ^{5/8}	5/16-24	4-12	7.439	.610	1 ^{1/4}	2 ^{1/4}

Add Stroke

ZB
7 ^{5/16}
7 ^{9/16}
7 ^{11/16}
7 ^{15/16}
7 ^{15/16}
7 ^{15/16}
7 ^{15/16}
7 ^{15/16}
7 ^{15/16}
7 ^{15/16}
7 ^{15/16}
8 ^{15/16}
9 ^{1/16}
9 ^{5/16}
9 ^{5/16}
9 ^{5/16}
9 ^{5/16}
9 ^{5/16}
9 ^{5/16}
9 ^{5/16}
9 ^{9/16}
9 ^{13/16}
9 ^{13/16}
9 ^{13/16}
9 ^{13/16}
9 ^{13/16}
9 ^{13/16}
9 ^{13/16}
9 ^{13/16}
11 ^{3/16}
11 ^{3/16}
11 ^{3/16}
11 ^{3/16}
11 ^{3/16}
11 ^{3/16}
11 ^{3/16}

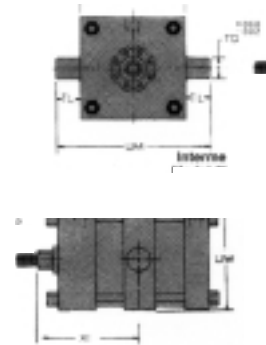

Intermediate Trunnion
Model 89-B (NFPA MT4)

Note: Pins are designed for shear, (not bending) loads.

* Note: Minimum "XI" dimension values shown apply only to the standard rod diameter. When oversized rods are used, minimum "XI" dimensions are increased by the difference between the "WB" dimension for the oversized rod and the "WB" dimension for the standard rod diameter. For Model 89, specify dimension "XI" when ordering.

** Note: Consult Miller Fluid Power's Engineering Department for shorter stroke requirements.

Miller Series A Air Cylinders & Series J Hydraulic Cylinders

Fixed Clevis, Detachable Clevis, Rear Eye
8" – 20" Bore Cylinders

Model 84-B (NFPA MP1)
Bolted Bushing
Fixed Clevis
(Pivot Pin Included)

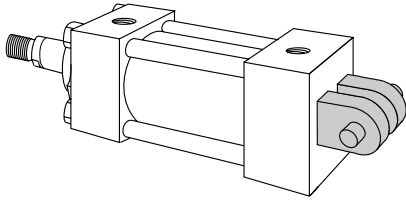

Mounting Dimensions
(See tables on opposite page)

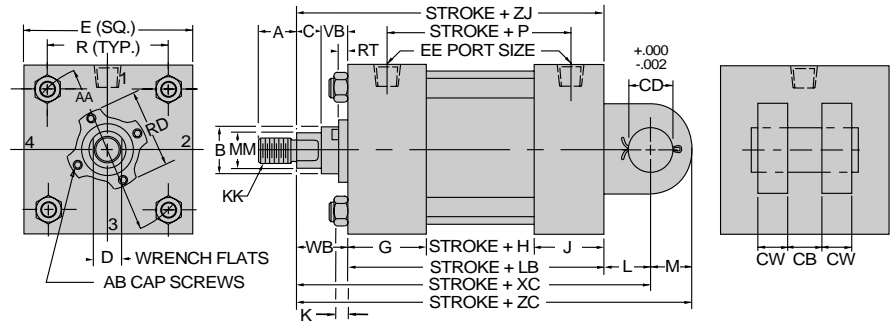

Model 86-B (NFPA MP2)
Bolted Bushing
Detachable Clevis
(Pivot Pin Included)

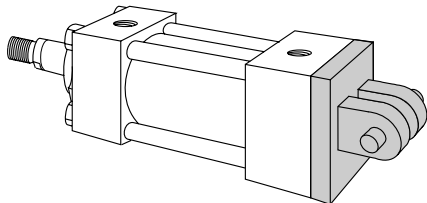

Mounting Dimensions
(See tables on opposite page)

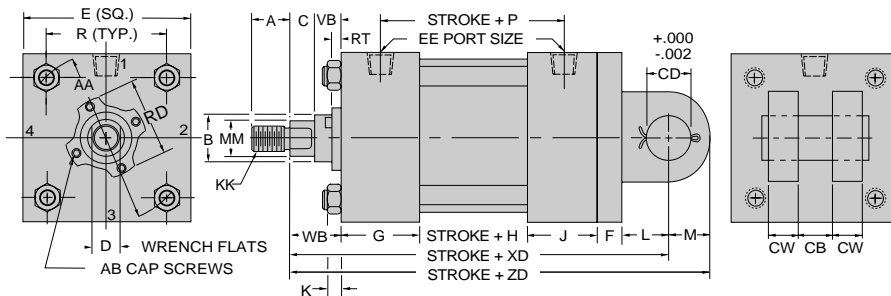

Model 90-B (NFPA MP3)
Bolted Bushing
Rear Eye
(Pivot Pin Included)

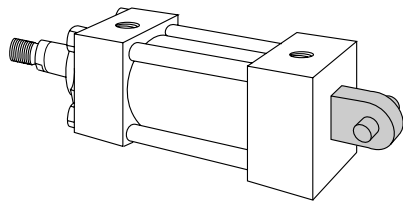

Mounting Dimensions
(See tables on opposite page)

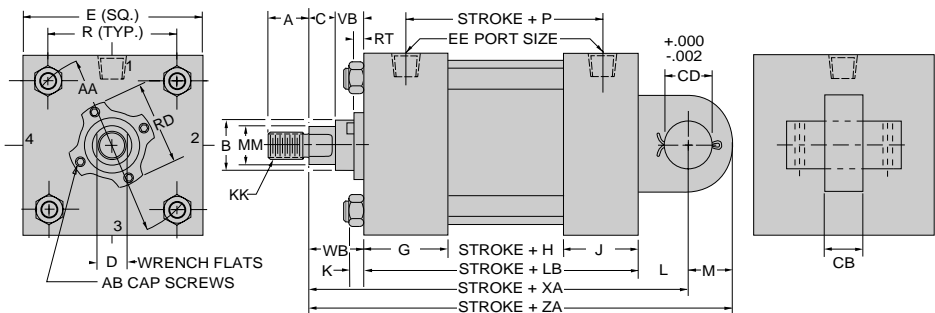

Common Rod End Styles & Dimensions (See page 56 for complete listing of rod end styles.)

Style No. 2-Standard
Threaded on Turndown Section

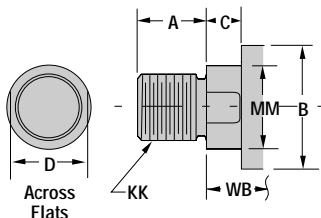

Style No. 4
Short Rod End-Internal Threads

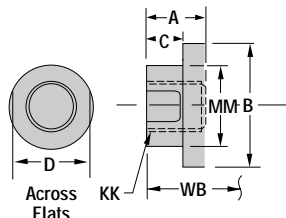

Style No. 6
Studded Rod End

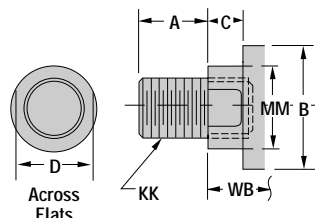

Rod End Styles

Rod End Style 2 is the standard rod end on Miller Fluid Power cylinders and will be furnished unless otherwise specified.

The rod end styles shown on this page represent most of the more commonly used rod end connections. If a rod end is required other than any of those shown, it would be machined from the Style "O" Rod end and identified as a Style "O" modified.

Rod end modifications to your specifications can be readily made and could include a radius, a spherical radius, special thread size or length or both, keyway, special drilled holes and many other variations too numerous to mention.

Rod Dia. mm.	A	AC	AD	AE	AF	C	D	IM	KK	CC	LG
5/8	3/4	1 1/8	5/8	1/4	3/8	3/8	1/2*	1/2-20	7/16-20	5/8-18	1/2
1	1 1/8	1 1/2	15/16	3/8	1 1/16	1/2	7/8*	7/8-14	3/4-16	1-14	13/16
1 3/8	1 5/8	1 3/4	1 1/16	3/8	7/8	5/8	1 1/8	1 1/4-12	1-14	1 3/8-12	1 1/4
1 3/4	2	2	1 5/16	1/2	1 1/8	3/4	1 1/2	1 1/2-12	1 1/4-12	1 3/4-12	1 5/8
2	2 1/4	2 5/8	1 11/16	5/8	1 3/8	7/8	1 11/16	1 3/4-12	1 1/2-12	2-12	1 7/8
2 1/2	3	3 1/4	1 5/16	3/4	1 3/4	1	2 1/16	2 1/4-12	1 7/8-12	2 1/2-12	2 5/8
3	3 1/2	3 3/4	2 7/16	7/8	2 1/4	1	2 5/8	2 3/4-12	2 1/4-12	3-12	3 1/8
3 1/2	3 1/2	4 3/8	2 11/16	1	2 1/2	1	3	3 1/4-12	2 1/2-12	3 1/2-12	3 1/8
4	4	4 1/2	2 11/16	1	3	1	3 3/8	3 3/4-12	3-12	4-12	3 5/8
4 1/2	4 1/2	5 1/4	3 3/16	1 1/2	3 1/2	1	3 7/8	4 1/4-12	3 1/4-12	4 1/2-12	4 1/8
5	5	5 3/8	3 3/16	1 1/2	3 7/8	1	4 1/4	4 3/4-12	3 1/2-12	5-12	4 5/8
5 1/2	5 1/2	6 1/4	3 5/16	1 7/8	4 3/8	1	4 5/8	5 1/4-12	4-12	5 1/2-12	5 1/8

*For Style #1 Rod End "D" Dimension: 5/8" Rod D = 7/16"
1" Rod D = 13/16"

<p>Style 0</p> <p>Plain Rod No Thread No Flats</p>	
<p>Style 1</p> <p>Full Male Thread</p>	
<p>Style 2</p> <p>Standard Turndown Male Thread</p>	
<p>Style 3</p> <p>Long Rod Female Thread</p>	
<p>Style 4</p> <p>Short Rod Female Thread</p>	
<p>Style 5</p> <p>Intermediate Male Thread</p>	
<p>Style 6</p> <p>Studded Rod End (Available thru 2" Rod Dia.)</p>	
<p>Style 7</p> <p>Turndown Male Thread (2X A)</p>	
<p>Style 8</p> <p>Intermediate Male Thread (2X A)</p>	
<p>Style 9</p> <p>Flange Coupling Rod End</p>	

Miller Series A Air Cylinders & Series J Hydraulic Cylinders

Selecting Rod End Accessories

Cylinder rod end accessories are used to affix the piston rod to the load-most commonly when the cylinder pivots during piston motion. The use of a pivot pin is required.

Piston Rod Attachments-In attaching machinery components or rod clevises, rod eyes, etc., to Miller Style 2 (Threaded or Turndown Section) or Style 4 (Internally Threaded) Piston Rods, the attachments should be tightened to the torques given in the table at right. This torque or pre-stress triples the fatigue strength of the rod's threaded section and makes a stronger assembly than attaching the machinery component to a full diameter threaded rod (Style 1) and torquing it against a lock nut. Miller recommends the Style 2 (Threaded or Turndown Section) Rod for most applications. Its square shoulder design helps assure proper alignment of cylinder to mechanism, eliminates needs for a jam nut, provides fixed point for more accurate cylinder positioning, simplifies piloting to full rod diameter into mating part, and permits easier assembly of seals over rod without damage.

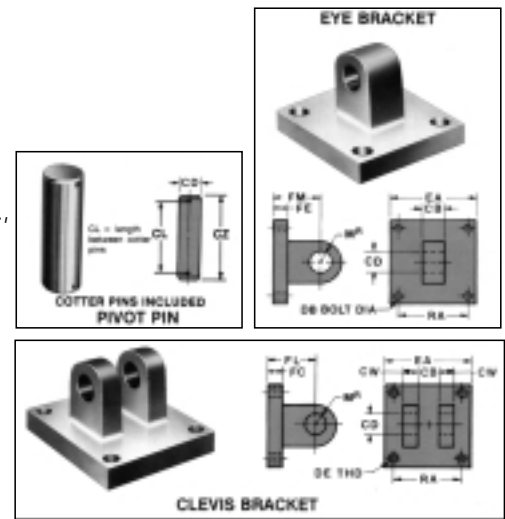

Pivot Pin Part No. Shear Load Capacity (lbs)	Eye Bracket Part No. Tensile Load Capacity (lbs)	Clevis Bracket Part No. Tensile Load Capacity (lbs)	Pin Dia	M	CB	CD	CL	CW	CZ	DB	DE	EA	FC	FE	FL	FM	RA
057-PP001-50 4,900	057-EB001-50 3,600	170-MB86A-150-50 5,000	1/2	1/2	3/4	1/2	1.94	1/2	2.28	3/8	3/8-24	2 1/2	3/8	3/8	1 1/8	1 1/8	1.63
057-PP001-75 11,000	—	170-MB86A-200-75 11,000	3/4	3/4	1 1/4	3/4	2.72	5/8	3.09	—	1/2-20	3	5/8	—	1 7/8	—	2.05
—	† 057-EB001-75 11,000	—	3/4	3/4	1 1/4	3/4	2.72	—	3.09	1/2	—	3 1/2	—	5/8	—	1 7/8	2.55
057-PP001-75 11,000	—	170-MB86A-250-75 11,000	3/4	3/4	1 1/4	3/4	2.72	5/8	3.09	1/2	1/2-20	3 1/2	5/8	5/8	1 7/8	1 7/8	2.55
057-PP001-100 19,600	057-EB001-100 17,000	170-MB86A-325-100 17,000	1	1	1 1/2	1	3.22	3/4	3.59	5/8	5/8-18	4 1/2	3/4	3/4	2 1/4	2 1/4	3.25
057-PP001-138 37,000	057-EB001-138 21,000	170-MB86A-400-138 30,000	1 3/8	1 3/8	2	1 3/8	4.25	1	4.66	5/8	5/8-18	5	7/8	7/8	3	3	3.82
057-PP001-175 60,000	057-EB002-175 51,000	170-MB86A-500-175 53,000	1 3/4	1 3/4	2 1/2	1 3/4	5.25	1 1/4	5.66	7/8	7/8-14	6 1/2	7/8	1	3 3/8	3 1/4	4.95
057-PP002-200 78,500	057-EB002-200 76,500	170-MB86A-600-200 75,000	2	2	2 1/2	2	5.28	1 1/4	5.72	1	1-14	7 1/2	1	1 1/2	3 1/2	4	5.73
057-PP002-250 122,700	057-EB002-250 94,500	170-MB86A-700-250 76,000	2 1/2	2 1/2	3	2 1/2	6.31	1 1/2	6.78	1 1/8	1 1/8-12	8 1/2	1	1 1/2	4	4 1/2	6.58

† Dimensions apply to eye bracket only.

Note: Do not order clevis bracket to convert cylinders to 86 mounting. Contact factory.

Rod Eye Part No. + Load Capacity (lbs)	Rod Clevis Part No. + Load Capacity (lbs)	Thd Size KK	A	MC	ME	CA	CB	CE	CD	CW
057-RE001-44-20 5,000	057-RC001-44-20 4,250	7/16-20	3/4	1/2	1/2	1 1/2	3/4	1 1/2	1/2	1/2
057-RE001-75-16 12,100	057-RC001-75-16 11,200	3/4-16	1 1/8	3/4	3/4	2 1/16	1 1/4	2 3/8	3/4	5/8
057-RE001-100-14 21,700	057-RC001-100-14 19,500	1-14	1 5/8	1	1	2 13/16	1 1/2	3 3/8	1	3/4
057-RE001-125-12 33,500	057-RC001-125-12 33,500	1 1/4-12	2	1 3/8	1 3/8	3 7/16	2	4 1/8	1 3/8	1
057-RE001-150-12 45,000	057-RC001-150-12 45,600	1 1/2-12	2 1/4	1 3/4	1 3/4	4	2 1/2	4 1/2	1 3/4	1 1/4
057-RE001-188-12 75,000	057-RC001-188-12 65,600	1 7/8-12	3	2	2	5	2 1/2	5 1/2	2	1 1/4
057-RE001-225-12 98,700	057-RC001-225-12 98,200	2 1/4-12	3 1/2	2 1/2	2 1/2	5 13/16	3	6 1/2	2 1/2	1 1/2
057-RE001-250-12 110,000	057-RC001-250-12 98,200	2 1/2-12	3 1/2	2 3/4	3	6 1/8	3	6 3/4	3	1 1/2

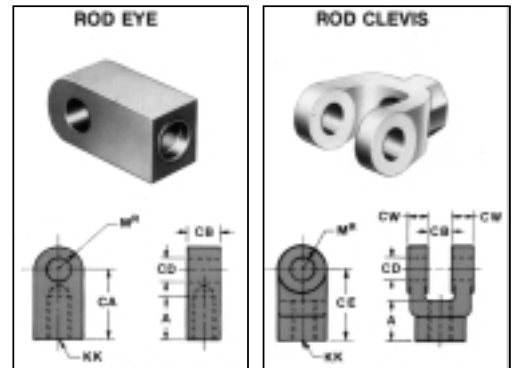

Miller Series A Air Cylinders

Standard Air Cylinders Parts List and Seal Kits

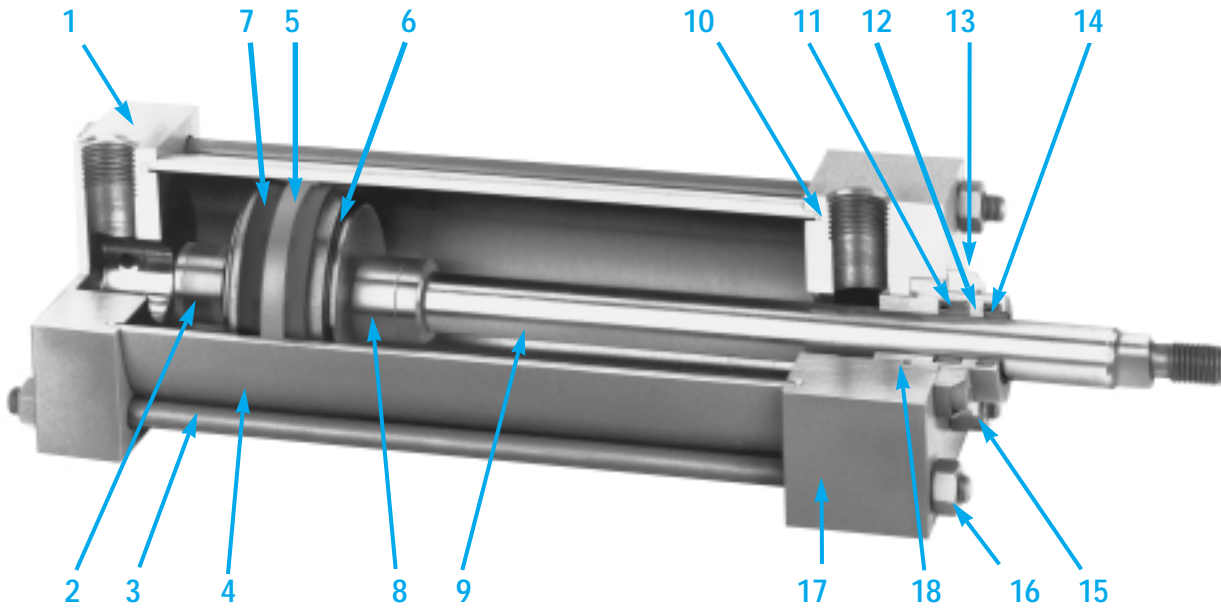

Rod Diameter	Bolted Bushing Rod Seal Kit Part # 11, 12, 13, 14, 18	Retainer Bushing Rod Seal Kit Part # 11, 12, 14, 18
5/8	051-KR075-63	051-KR074-63
1	051-KR075-100	051-KR074-100
1 3/8	051-KR075-138	051-KR074-138
1 3/4	051-KR075-175	051-KR074-175
2	051-KR075-200	051-KR074-200
2 1/2	051-KR075-250	051-KR074-250
3	051-KR075-300	051-KR074-300
3 1/2	051-KR075-350	051-KR074-350
4	051-KR075-400	051-KR074-400
4 1/2	051-KR075-450	051-KR074-450
5	051-KR075-500	051-KR074-500
5 1/2	051-KR075-550	051-KR074-550

- 1. Cap
- 2. Cap End Cushion Plunger
- 3. Tie Rod (4)
- 4. Tube
- 5. Wear Band
- 6. Piston
- 7. Piston Seal (2)
- 8. Rod End Cushion Plunger
- 9. Piston Rod
- 10. Tube End Seal (2)
- 11. Rod Seal
- 12. Bushing
- 13. Bushing Retainer
- 14. Rod Wiper
- 15. Socket Head Cap Screws
- 16. Tie Rod Nuts
- 17. Head
- 18. Bushing O-Ring
- 19. Back up O-Ring
- 20. Seal Ring (1)

Bore	Bore Kit Part # 5, 7, 10	SEAL RING PISTON SEALS	
		#20 (1 Required)	#19 (1 Required)
1 1/2	090-KB001-150	052-PS029-150	008-RG006-125
2	090-KB001-200	052-PS029-200	008-RG006-175
2 1/2	090-KB001-250	052-PS029-250	008-RG006-225
3 1/4	090-KB001-325		
4	090-KB001-400		
5	090-KB001-500		
6	090-KB001-600		
7	090-KB001-700		
8	090-KB001-800		
10	090-KB001-1000		
12	090-KB001-1200		
14	090-KB001-1400		
16	090-KB001-1600		
18	090-KB001-1800		
20	090-KB001-2000		

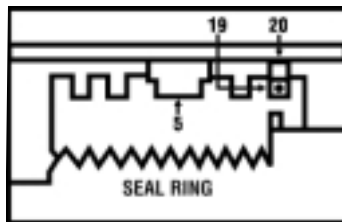

Seal ring construction is standard on the following small bore maximum oversize rod cylinder. 1-1/2" bore 1" rod, 2" bore 1-3/8" rod, and 2-1/2" bore 1-3/4" rod.

IMPORTANT: When ordering parts, specify the 8-digit serial number and part name as shown. Serial number can be found on the cylinder name tag or stamped on the head and cap near the ports.

Miller Series J Hydraulic Cylinders

Standard Hydraulic Cylinders Parts List and Seal Kits

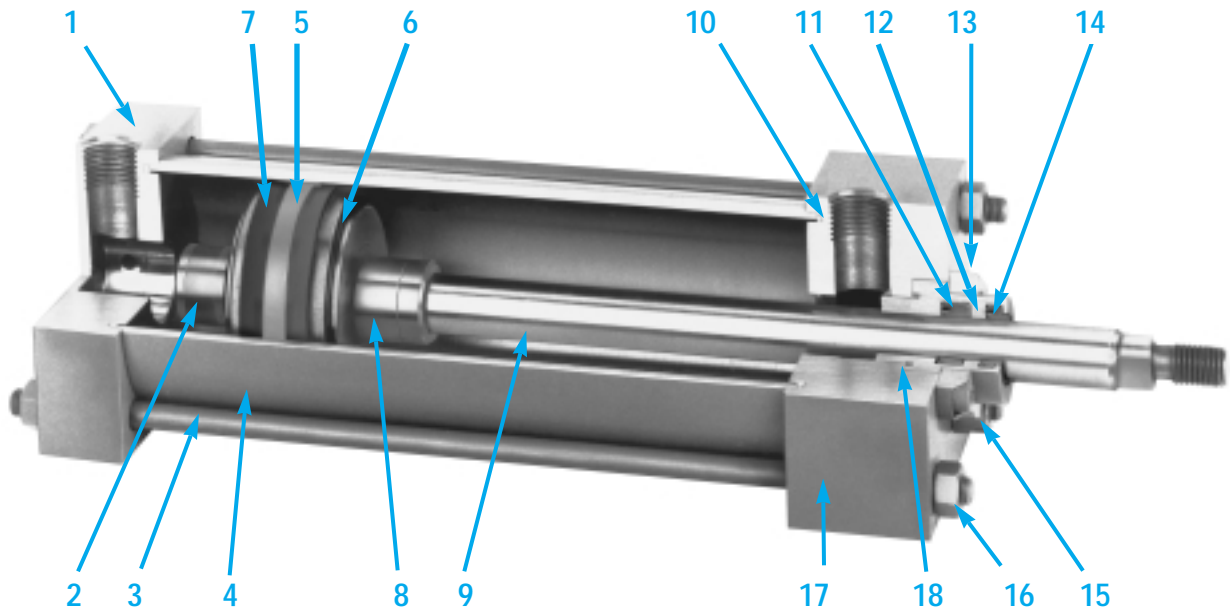

Rod Diameter	Bolted Bushing Rod Seal Kit Part # 11, 12, 13, 14, 18	Retainer Bushing Rod Seal Kit Part # 11, 12, 14, 18
5/8	051-KR075-63	051-KR074-63
1	051-KR075-100	051-KR074-100
1 3/8	051-KR075-138	051-KR074-138
1 3/4	051-KR075-175	051-KR074-175
2	051-KR075-200	051-KR074-200
2 1/2	051-KR075-250	051-KR074-250
3	051-KR075-300	051-KR074-300
3 1/2	051-KR075-350	051-KR074-350
4	051-KR075-400	051-KR074-400
4 1/2	051-KR075-450	051-KR074-450
5	051-KR075-500	051-KR074-500
5 1/2	051-KR075-550	051-KR074-550

- 1. Cap
- 2. Cap End Cushion Assembly
- 3. Tie Rod (4)
- 4. Tube
- 5. Wear Band
- 6. Piston
- 7. Piston Seal (2)
- 8. Rod End Cushion Plunger
- 9. Piston Rod
- 10. Tube End Seal (2)
- 11. Rod Seal
- 12. Bushing
- 13. Bushing Retainer
- 14. Rod Wiper
- 15. Socket Head Cap Screws
- 16. Tie Rod Nuts
- 17. Head
- 18. Bushing O-Ring
- 19. Piston Rings (4)
- 20. Retaining Ring
- 21. Pressure Ring for Piston Seal
- 22. Wave Spring for Piston Seal

Bore	Bore Kit Part # 5, 7, 10
1 1/2	091-KB001-150
2	091-KB001-200
2 1/2	091-KB001-250
3 1/4	091-KB001-325
4	091-KB001-400
5	091-KB001-500
6	091-KB001-600
7	091-KB001-700
8	091-KB001-800
10	091-KB001-1000
12	091-KB001-1200
14	091-KB001-1400
16	091-KB001-1600
18	091-KB001-1800
20	091-KB001-2000

PISTON RING SEALS	
#19 (4 Required)	
1 1/2	052-PS027-150
2	052-PS027-200
2 1/2	052-PS027-250

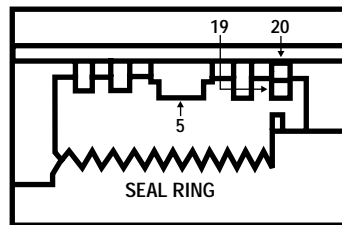

Seal ring construction is standard on the following small bore maximum oversize rod cylinder. 1-1/2" bore 1" rod, 2" bore 1-3/8" rod, and 2-1/2" bore 1-3/4" rod.

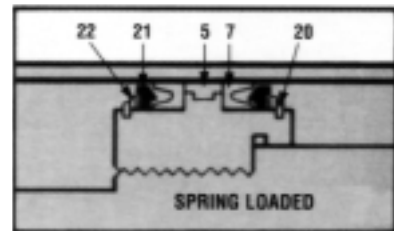

IMPORTANT: When ordering parts, specify the 8-digit serial number and part name as shown. Serial number can be found on the cylinder name tag or stamped on the head and cap near the ports.

Miller Series A Air Cylinders & Series J Hydraulic Cylinders

How To Order

Example: J-72B2N-004.00-008.00-01.00-N 1 1 9

J - 72 B 2 N - 004.00 - 008.00 - 01.00 - N 1 1 9

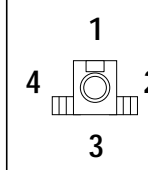
Series	Mounting Style	Bushing	Rod End Style	Cushions **	Bore Dia.	Stroke	Rod Dia.	Port Type	Port Location		Modified
A DA J DJ (D= Dbl. Rod End)		B= Bolted Bushing R= Retainer Held Bushing	#0 #1 #2 (Std) #3 #4 #5 #6 #7 #8 #9	R= Rod End Cushioned C= Cap End Cushioned B= Both Ends Cushioned N= Non-Cushioned				N= NPT	Head End 1 (Std.) 2 3 4	Cap End 1 2 3 4	0= Standard 9= Modified (See * Below)
											

Note: The Standard (#1) port location is at the top of the cylinder in relation to the mountings as shown on the mounting dimensional pages in this catalog. These numbered locations are shown within the end views of the cylinders for each of the mountings indicated.

* The number 9 refers to any modifications from standard design. Non-standard modifications and options not identified in the part number identification above must be included on all orders.

** The standard cushion adjustment screw location is position #2. Ball check is position #4.

Miller Fluid Power

Main Plant
800 North York Road
Bensenville, IL 60106
(630) 766-3400—Local
(800) 323-2520—Elsewhere
(630) 350-0294—FAX

Miller Fluid Power

33067 Industrial Road
Livonia, MI 48150
(800) 323-2520

Miller Fluid Power

2050 Del Rio
Ontario, CA 91761
(800) 323-2520

Miller Fluid Power Canada Ltd.

1214 Kamato
Mississauga, Ontario, Canada L4W 1Y1
(800) 268-0205—Ontario & Quebec
(905) 625-2780—Elsewhere
(905) 625-8724—FAX

Miller Potencia Fluida, S.A. de C.V.

Israel No. 301 Esq. Damasco
Col. Ricardo B. Anaya 2A. SECC
Apartado Postal F-1241
78090 San Luis Potosi, S.L.P. Mexico
(48) 21-19-21, 22, 37
(48) 21-21-60—FAX

Miller Potencia Fluida, S.A. de C.V.

Zahuatlan No. 31
Desp. 4 Fracc. San Javier
Tlalnepantla de Baz, Edo. de Mexico
53 90 26 06
53 90 26 07
53 90 63 63—FAX

Miller Fluid Power (UK) Ltd.

Unit 3, Bailey Drive
Norwood Industrial Estate
Killamarsh, Sheffield
South Yorkshire, England S31 8HB
(441)-462-438303
(441)-462-420901—FAX

All specifications and information subject to
change without notice or prior obligation.

File 7622 020007

