

07L Mist Lubricators – Standard

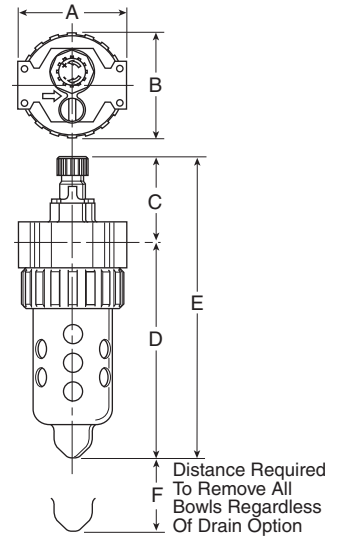

Features

- Proportional oil delivery over a wide range of air flows.
- Precision needle valve assures repeatable oil delivery and provides simple adjustment of delivery rate.
- Bowl can be filled while air line is under pressure.
- Transparent sight dome for 360° visibility.
- High Flow: 1/2" – 90 SCFM[§]
 3/4" – 90 SCFM[§]



Distance Required To Remove All Bowls Regardless Of Drain Option

Port Size	NPT	
	Twist Drain	No Drain
Poly Bowl † / Metal Guard		
1/2"	—	07L32B*
3/4"	—	07L42B*
Metal Bowl / Sight Gauge		
1/2"	07L34B*	—
3/4"	07L44B*	—

07L Lubricator Dimensions		
A 3.24 (82)	B 3.25 (83)	C 2.41 (61)
D 6.86 (174)	D† 6.95 (177)	E 9.09 (231)
E† 9.35 (237)	F 2.75 (70)	

Inches (mm)
 † With Twist Drain.

Standard part numbers shown bold. For other models refer to ordering information below.

† For polycarbonate bowl and sight dome, see Caution on page C2.

§ SCFM = Standard cubic feet per minute at 90 psig inlet and 5 psig pressure drop.

Ordering Information

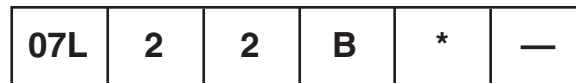

Port Size	Bowl Options		Options	Engineering Level	Port Type
3 1/2 Inch 4 3/4 Inch	<u>Polycarbonate Bowl</u> 2 Metal Bowl Guard / No Drain 6 Metal Bowl Guard / Pressure Fill K Metal Bowl Guard / Auto Fill Device N Metal Bowl Guard / Twist Drain	<u>Metal Bowl</u> 4 Sight Gauge / Twist Drain 8 Sight Gauge / Pressure Fill M Sight Gauge / Auto Fill Device	B With Fill Plug C With Fill Plug/Nylon Sight Dome F With Body Pressure Fill G With Body Pressure Fill / Nylon Sight Dome	* Will be Entered at Factory	Blank NPT 1* BSPP * 1/2 inch meets ISO 1179-1 Standard.

BOLD ITEMS ARE MOST POPULAR.



Technical Specifications – 07L

Technical Information

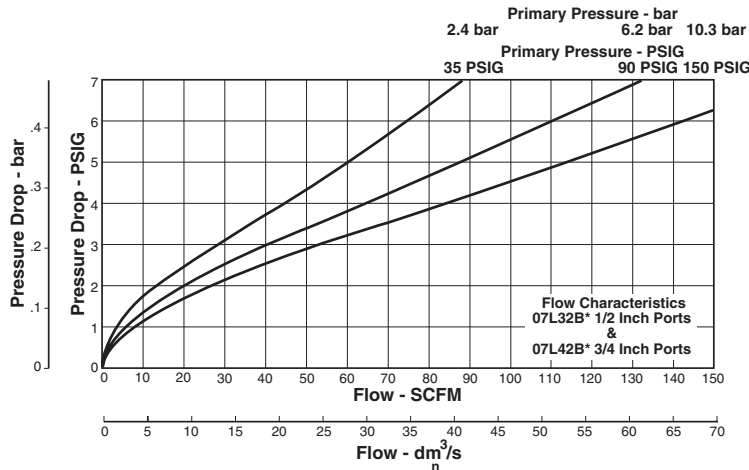

07L Mist Lubricator Kits & Accessories

Adjustment Knob	P04121
Bowl Guard Kit	PS805P
Bowl Kits –	
Poly Bowl – No Drain.....	PS846P
Twist Drain	PS817P
Pressure Fill.....	PS819P
Remote Fill.....	PS828P
Metal Bowl – Sight Gauge / Twist Drain.....	PS829P
Sight Gauge / Pressure Fill.....	PS820P
Drain Kit – Twist Drain	PS512P
Fill Cap Kit.....	PS741P
Lubricator Service Kit	PS718P
Mounting Bracket Kit	PS843P
Oil – 1 Gal.....	F442002
12 Quart Case.....	F442003
4 Gallon Case	F442005
Pressure Fill Adapter Kit	PS716P
Pressure Fill Button	P11912
Remote Auto-Fill Device	PS505CP
Sight Dome / Fill Cap Kit	PS738P
Sight Dome Kit	PS740P
Nylon Sight Dome Kit	PS740N

Specifications

Bowl Capacity	6.0 Ounces
Minimum Flow for Lubrication5 SCFM At 100 psig
Port Threads.....	1/2, 3/4 Inch
Pressure & Temperature Rating –	
Polycarbonate Bowl – 0 to 150 psig (0 to 10.3 bar)	
32°F to 125°F (0°C to 52°C)	
Metal Bowl – 0 to 250 psig (0 to 17.2 bar)	
32°F to 175°F (0°C to 80°C)	
Suggested Lubricant	F442 Oil
Petroleum based oil of 100 to 200 SSU viscosity at 100°F (38°C)	
and an aniline point greater than 200°F (93°C).	
(DO NOT USE OILS WITH ADDITIVES, COMPOUNDED OILS	
CONTAINING SOLVENTS, GRAPHITE, DETERGENTS, OR	
SYNTHETIC OILS.)	
Weight	1.9 lb. (0.9 kg)
Materials of Construction	
Body	Zinc
Bowls – Transparent	Polycarbonate
Metal (With Sight Gauge).....	Zinc
Bowl Guard	Steel
Collar	Plastic or Metal
Drain – Twist – Body & Nut	Plastic
Injector Meter Block & Base Assembly	Plastic
Seals.....	Nitrile
Sight Dome	Polycarbonate
Sight Gauge	Polyamide (Nylon)

C
Product Selection
Filters
Coalescers
Regulators
Filter / Regulators
Lubricators
Combos
Accessories

