

**R24, R25 Regulators – Miniature (Air / Water Service)**

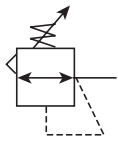

**Features**

- Lightweight Plastic Body
- Constructed with a Combination of N.S.F. and F.D.A. Approved Materials
- Unbalanced Poppet Standard
- Non-rising, Push-to-lock Adjusting Knob
- Compact, 3.10 inch (79mm) high by 1.60 inch (41mm) wide
- Lightweight
- Diaphragm Operated

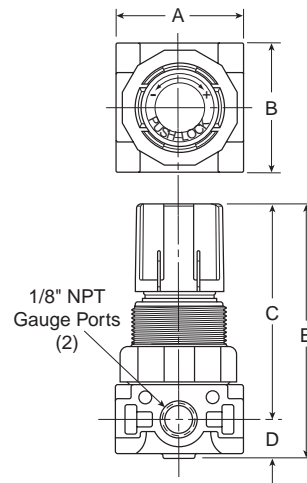

Port Size	NPT	
	Air Service Relieving	Water Service Non-Relieving
	Relieving, 0-125 Reduced Pressure, Without Gauge	
1/8"	<b>R25-01C</b>	<b>R24-01CK</b>
1/4"	<b>R25-02C</b>	<b>R24-02CK</b>

R24, R25 Regulator Dimensions		
A	B	C
1.60 (41)	1.60 (41)	2.61 (66)
D	E	
0.49 (13)	3.10 (79)	

Inches (mm)

**Bold Items are Most Popular.**

For other models refer to ordering information below.

NOTE: 1.250 Dia. (31.8mm) hole required for panel mounting.

**Ordering Information**

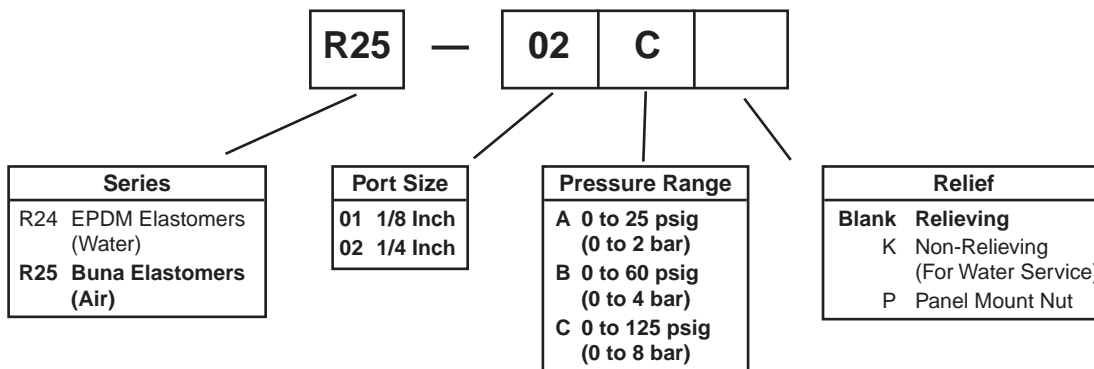

**BOLD ITEMS ARE MOST POPULAR.**



**Technical Specifications – R24 / R25**

**Technical Information**

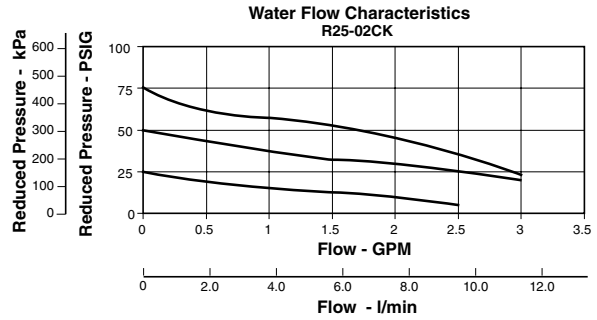
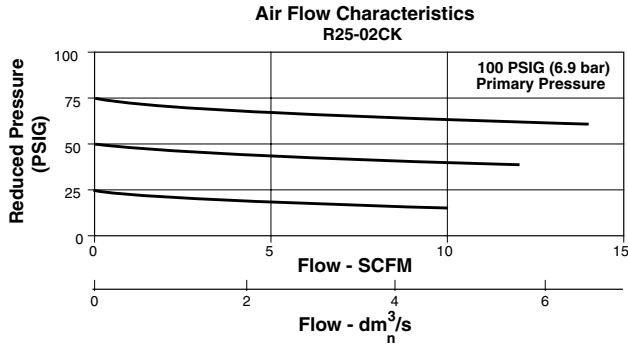

**CAUTION:**

**REGULATOR PRESSURE ADJUSTMENT** – The working range of knob adjustment is designed to permit outlet pressures within their full range. Pressure adjustment beyond this range is also possible because the knob is not a limiting device. This is a common characteristic of most industrial regulators, and limiting devices may be obtained only by special design.

For best performance, regulated pressure should always be set by increasing the pressure up to the desired setting.

**⚠ WARNING**

**Product rupture can cause serious injury.  
Do not connect regulator to bottled gas.  
Do not exceed maximum primary pressure rating.**

**R24, R25 Regulator Kits and Accessories**

- Panel Mount Nut – Plastic .....R05X51-P
- Aluminum .....R05X51-A
- Mounting Bracket and Nut ..... SA161X57
- Service Kits – Relieving (Buna) ..... RKR25Y
- Non-Relieving (Buna) .....RKR25KY
- Relieving (EPDM) ..... RKR24Y
- Non-Relieving (EPDM) ..... RKR24KY
- Springs – 0-25 psig Spring..... SPR-375-1
- 0-60 psig Spring.....SPR-376
- 0-125 psig Spring.....SPR-377

**Specifications**

- Gauge Ports (2) ..... 1/8 Inch  
(Can be used for full flow)
- Pressure Rating – Maximum Inlet Pressure 150 psig.....(10.0 bar)
- Port Threads ..... 1/8, 1/4 Inch
- Temperature Rating ..... 40°F to 125°F (4°C to 52°C)
- Weight .....0.25 lb. (0.11 kg)

**Materials of Construction**

- Adjusting Screw ..... Steel
- Body ..... Acetal
- Bonnet and Seat ..... Acetal
- Diaphragm (R25)..... Buna N
- Diaphragm (R24)..... EPDM
- Seals (R25) ..... Buna N
- Seals (R24) ..... EPDM
- Springs ..... Stainless Steel
- Valve Poppet (R25)..... Buna N
- Valve Poppet (R24)..... EPDM



<b>C</b>	Product Selection
Filters	Coalescers
Regulators	Filter / Regulators
Lubricators	Compos
Accessories	