

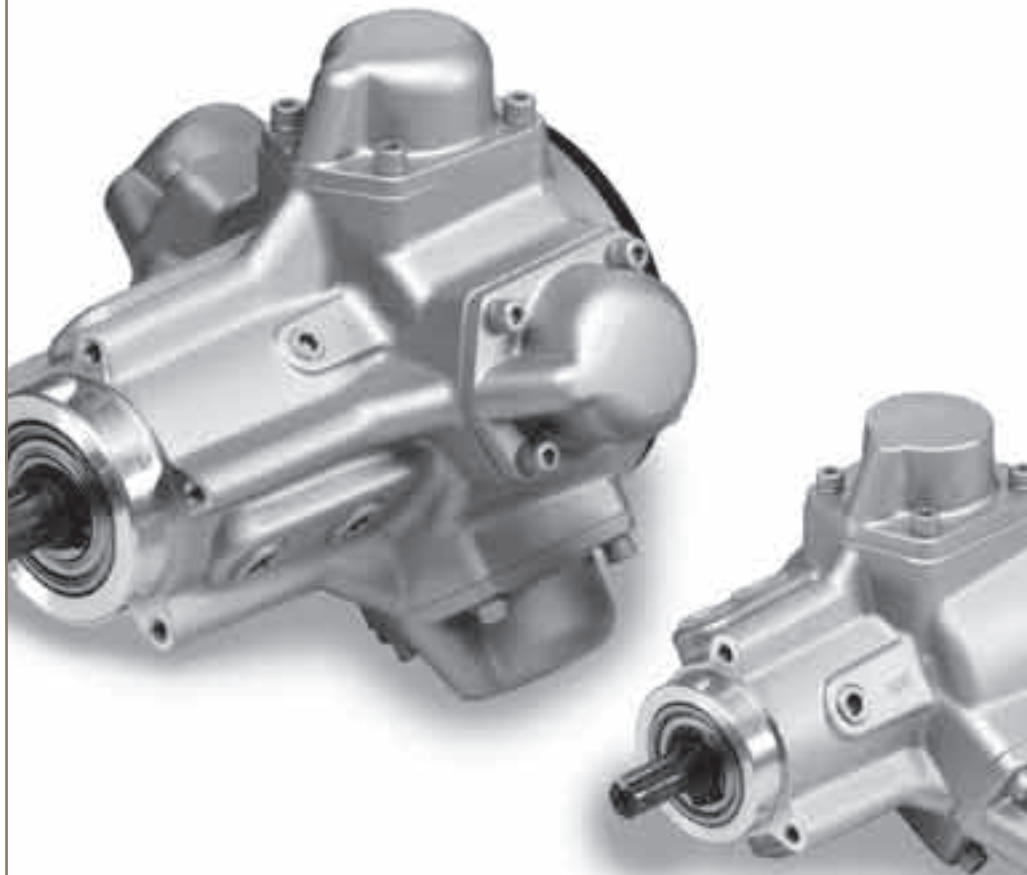

aerospace
climate control
electromechanical
filtration
fluid & gas handling
hydraulics
pneumatics
process control
sealing & shielding

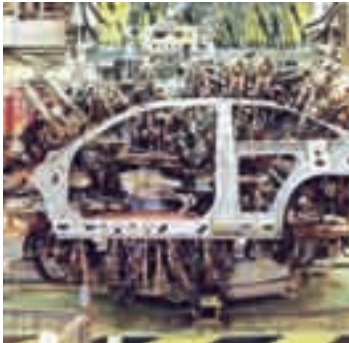

Radial Piston Air Motors

Series P1V-P



ENGINEERING YOUR SUCCESS.

www.comoso.com

Features	Air motor	Hydraulic motor	Electric motor	Electric motor regulated	Electric motor regulated with feed back
Overload safe	***	***	*	**	***
Increased torque at higher loads	***	**	*	**	***
Easy to limit torque	***	***	*	*	***
Easy to vary speed	***	***	*	***	***
Easy to limit power	***	***	*	**	***
Reliability	***	***	***	***	***
Robustness	***	***	*	*	*
Installation cost	***	*	**	**	**
Ease of service	***	**	*	*	*
Safety in damp environments	***	***	*	*	*
Safety in explosive atmospheres	***	***	*	*	*
Safety risk with electrical installations	***	***	*	*	*
Risk of oil leak	***	*	***	***	***
Hydraulic system required	***	*	***	***	***
Weight	**	***	*	**	*
Power density	**	***	*	*	*
High torque for size	**	***	*	*	*
Noise level during operation	*	***	**	**	**
Total energy consumption	*	**	***	***	***
Service interval	*	**	***	***	***
Compressor capacity required	*	***	***	***	***
Purchase price	*	*	***	***	**
Accuracy, speed	*	**	*	**	***
Regulating dynamic	*	*	*	*	***
Communication	*	*	*	***	***

* = good, **=average, ***=excellent



Important!

Before carrying out service activities, make sure the air motor is vented. Before disassembling the motor, disconnect the primary air hose to ensure that the air supply is interrupted.



NOTE!

All technical data in the catalogue are typical values. The air quality is a major factor in the service life of the motor, see ISO 8573-1.



WARNING

FAILURE OR IMPROPER SELECTION OR IMPROPER USE OF THE PRODUCTS AND/OR SYSTEMS DESCRIBED HEREIN OR RELATED ITEMS CAN CAUSE DEATH, PERSONAL INJURY AND PROPERTY DAMAGE.

This document and other information from Parker Hannifin Corporation, its subsidiaries and authorized distributors provide product and/or system options for further investigation by users having technical expertise. It is important that you analyze all aspects of your application and review the information concerning the product or system in the current product catalog. Due to the variety of operating conditions and applications for these products or systems, the user, through its own analysis and testing, is solely responsible for making the final selection of the products and systems and assuring that all performance, safety and warning requirements of the application are met. The products described herein, including without limitation, product features, specifications, designs, availability and pricing, are subject to change by Parker Hannifin Corporation and its subsidiaries at any time without notice.

SALE CONDITIONS

The items described in this document are available for sale by Parker Hannifin Corporation, its subsidiaries or its authorized distributors. Any sale contract entered into by Parker will be governed by the provisions stated in Parker's standard terms and conditions of sale (copy available upon request).

Contents	Page
General	
Radial piston air motors P1V-P	4
Principles of radial piston motor operation	6
Torque, power and air consumption graphs	6
Correction diagram	7
Direction of motor rotation	7
Speed regulation	8
Air supply	8
Choice of components for air supply	9
Silencing.....	10
Sound levels.....	10
Compressed air quality	10
P1V-P Air Motors with brake.....	11
CE marking.....	11
Choice of air motor	12
Technical data	14
Table and diagram data	14
Material specification	14
Order key.....	15
Air Motors	
Data for reversible basic motor	16
Data for reversible basic motor with flange.....	16
Data for reversible basic motor with foot.....	16
Data for reversible basic motor with brake	17
Data for reversible basic motor with brake and flange	17
Data for reversible basic motor with brake and foot	17
Data for reversible motor with gearbox and flange.....	18
Data for reversible motor with gearbox and foot.....	19
Data for reversible motor with gearbox, brake and flange.....	20
Data for reversible motor with gearbox, brake and foot.....	21
Torque and power graphs	22-24
Dimensions	
Reversible basic motor	25-26
Reversible basic motor with flange	25-26
Reversible basic motor with foot	25-26
Reversible basic motor with brake	27-28
Reversible basic motor with brake and flange.....	27-28
Reversible basic motor with brake and foot.....	27-28
Reversible motor with gearbox and flange	29-30
Reversible motor with gearbox and foot	29-30
Reversible motor with gearbox, brake and flange	31-32
Reversible motor with gearbox, brake and foot	31-32
Theoretical calculations	33
Installation instructions	36

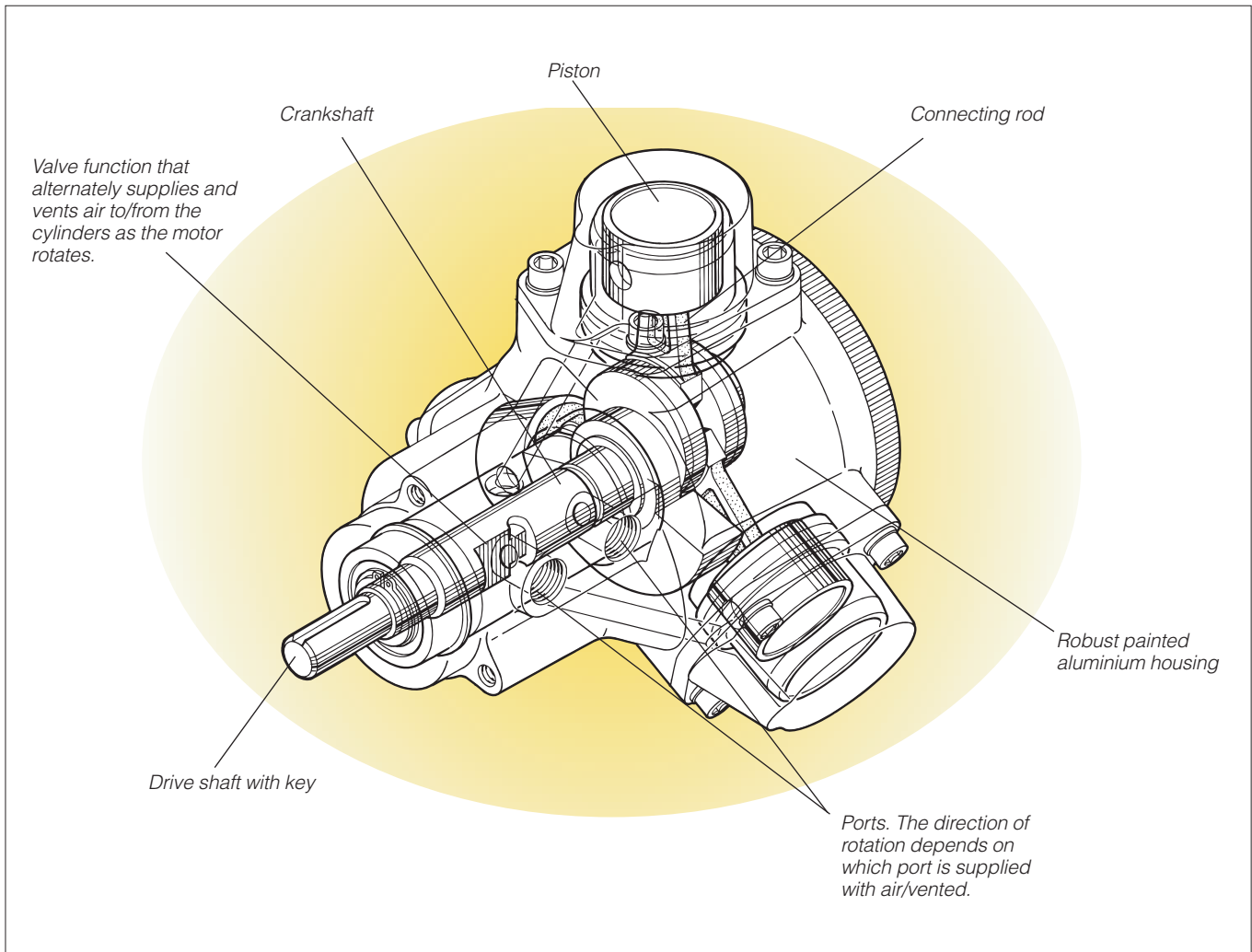

Radial piston air motors P1V-P

P1V-P is a range of air motors using the radial piston principle. Radial piston motors can operate at a low speed while delivering high torque.

The low speed keeps the noise level to a minimum, making this type of motor suitable for all applications that are subject to stringent noise level requirements.

The range includes three basic motors with 73.5, 125 and 228 watt power at 5 bar supply pressure. They can also be supplied with alternative flanges or foot brackets.

Various gearboxes are also available for these motors, to provide the right speed and torque for every application.

Almost every motor is also available in a model equipped with a spring-loaded braking unit, which releases its braking effect in response to a compressed air signal.

The P1V-P motors have an extremely robust structure, with a housing made of painted cast aluminium, and a strong outgoing keyed shaft made of steel.

The medium used by the P1V-P is oil mist. This makes the motors unique in that they require no servicing at all, apart from ensuring that the correct air quality is supplied.

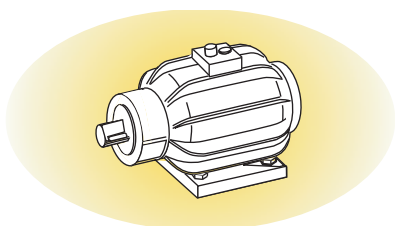

Air motors have much smaller installation dimensions than corresponding electric motors.

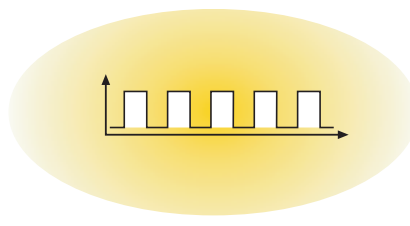

Air motors can be stopped and started continually without damage.

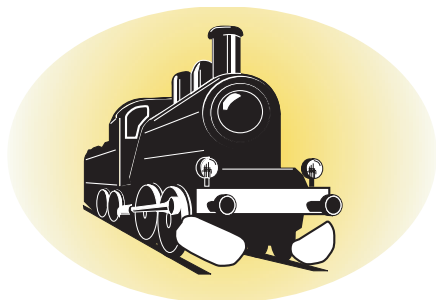

Air motors can be loaded until they stall, without damage. They are designed to be able to withstand the toughest heat, vibration, impact etc.

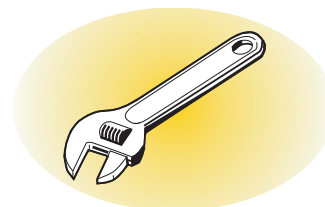

The simple design principle of air motors makes them very easy to service.

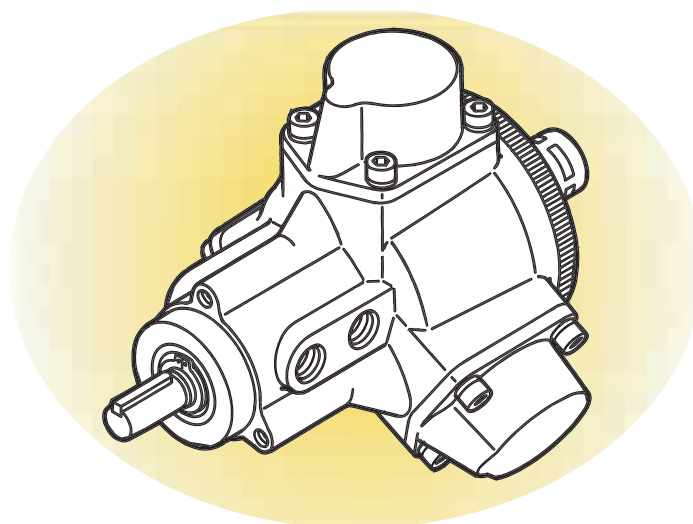

The weight of an air motor is several times less than corresponding electric motors.

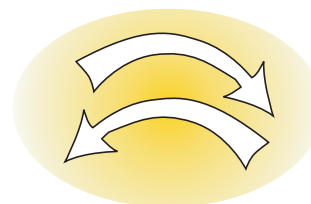

The motors are reversible as standard.

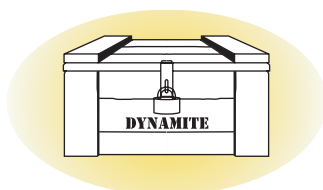

Air motors can be used in the harshest environments. Most P1V-S motors are ATEX certified.

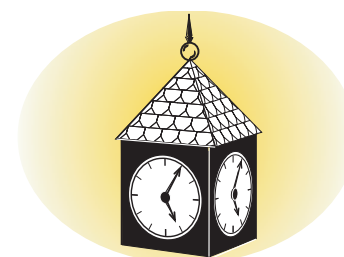

The reliability of air motors is very high, thanks to the design and the low number of moving parts.

Principles of radial piston motor operation

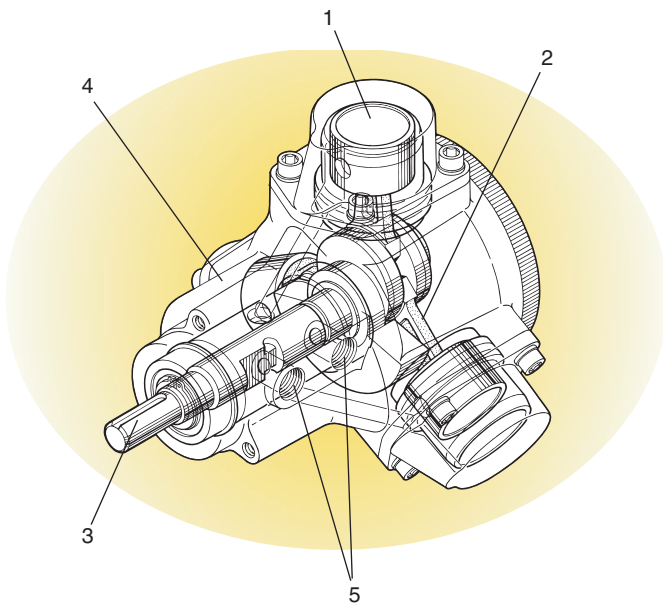

- 1 Piston
- 2 Connection rod
- 3 Shaft
- 4 Motor housing
- 5 Connection ports

Torque, power and air consumption graphs

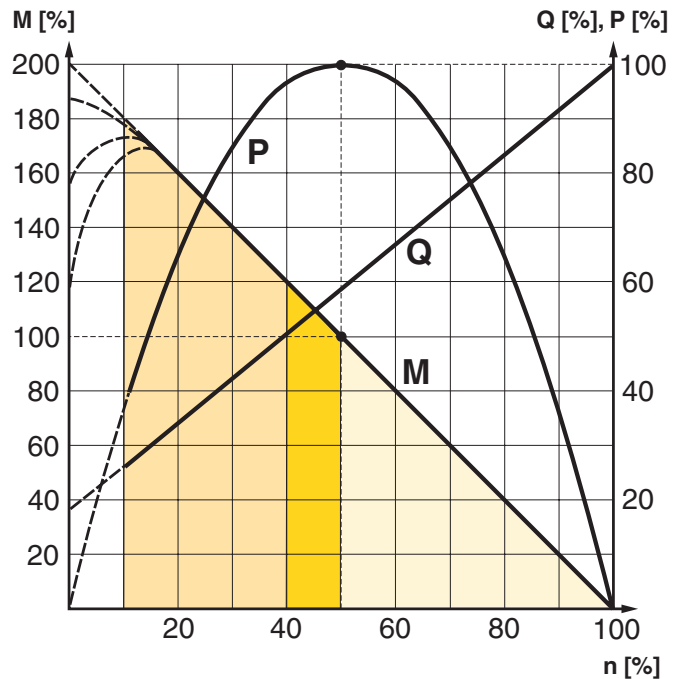

P = power **Q = air consumption**
M = torque **n = speed**

- Possible working range of motor.
- Optimum working range of motor.
- Working range with shorter service life

Air motors come in a wide range of different designs. For these motors, we have chosen the radial piston principle because of the low speed, high torque, low noise level and long service life with no service intervals.

Their compact dimensions and low weight mean these motors are easy to install in virtually all applications.

The P1V-P motors can also be fitted with a choice of gear-boxes with different gear ratios, to produce the desired speed and torque at the outgoing shaft for every application.

The motor is supplied with air at either port A or port B depending on the desired direction of rotation. If air is supplied to port A, port B is used as the exhaust port. To change the direction of rotation, air is supplied to port B and port A then acts as the exhaust port. The supply air from port A or B is distributed to the pistons (1) by means of the rotating valve function on the outgoing shaft (3). The pistons (1) are attached to the outgoing shaft (3) by means of the connecting rods (2), and the exhaust air from each cylinder is also passed back to port A or B via the rotating valve.

The performance characteristics of each motor are shown in a family of curves as above, from which torque, power and air consumption can be read off as a function of speed. Power is zero when the motor is stationary and also when running at free speed (100%) with no load. Maximum power (100%) is normally developed when the motor is braked to approximately half the free speed (50%).

Torque at free speed is zero, but increases as soon as a load is applied, rising linearly until the motor stalls.

As the motor can stop with the pistons in various positions, it is not possible to specify an exact starting torque. However, a minimum starting torque is shown in all tables.

Air consumption is greatest at free speed, and decreases with decreasing speed, as shown in the above diagram.

The radial piston motor should not be used at speeds higher than the load speed (speed at maximum power), as this significantly reduces the service life.

Correction diagram

Correction factor

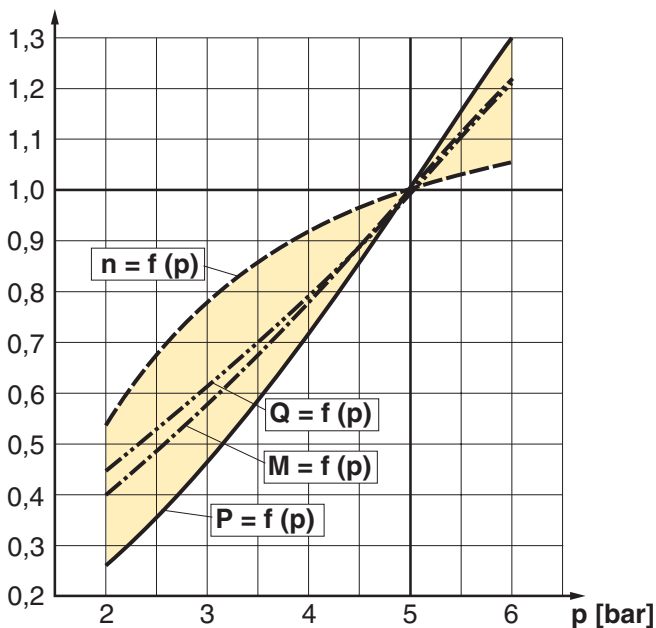

P = power **Q = air consumption**
M = torque **n = speed**

All catalogue data and curves are specified at a supply pressure of 6 bar (in the inlet port). This diagram shows the effect of pressure on speed, torque, power and air consumption.

Start off on the curve at the pressure used and then look up to the lines for power, torque, air consumption or speed. Read off the correction factor on the Y axis for each curve and multiply this by the specified catalogue data in the table or data read from the torque and power graphs.

Example: at 4 bar supply pressure, the power is only 0,55 x power at 6 bar supply pressure.

This example shows how rapidly the power rating of a motor decreases as the supply pressure is reduced. Therefore, it is critical to ensure that the proper pressure is supplied at the inlet port of the motor.

Direction of motor rotation

Basic motor- also with brake

The rotation direction on the output shaft is seen from the back of the motor (right-hand rotation = the motor can be used as a screwdriver to assemble one standard right-hand threaded screw)

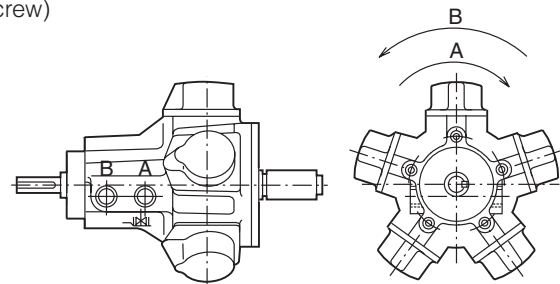

A port = Inlet, counter clockwise
 B port = Inlet, clockwise

Motor with gearbox

Motors equipped with gearboxes with low ratios (with or without brakes) works with rotation directions like the basic motors.

Motor	Ratio
P1V-P007**0440	5
P1V-P007**0220	10
P1V-P007**0147	15
P1V-P007**0110	20
P1V-P012**0360	5
P1V-P012**0180	10
P1V-P012**0120	15
P1V-P012**0090	20
P1V-P012**0060	30
P1V-P012**0050	40
P1V-P023**0300	5
P1V-P023**0150	10
P1V-P023**0100	15
P1V-P023**0075	20
P1V-P023**0050	30
P1V-P023**0038	40

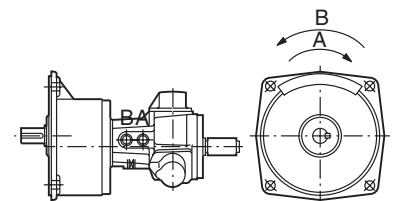

A port = Inlet, counter clockwise
 B port = Inlet, clockwise

All other P1V-P motors with higher ratios in the gearboxes to get the lowest speed and the highest torques are equipped with one more stage in the gearbox. This makes the direction of the rotation is opposite to the basic motors and the motors equipped with gearboxes with low ratios.

Motor	Ratio
P1V-P012**0040	50
P1V-P012**0030	60
P1V-P012**0022	80
P1V-P012**0018	100
P1V-P012**0015	120
P1V-P012**0012	160
P1V-P012**0009	200
P1V-P023**0030	50
P1V-P023**0025	60
P1V-P023**0018	80
P1V-P023**0015	100
P1V-P023**0012	120
P1V-P023**0009	160
P1V-P023**0007	200

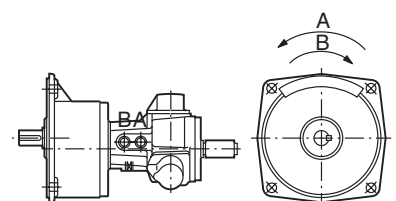

A port = Inlet, clockwise
 B port = Inlet, counter clockwise

Speed regulation

Throttling

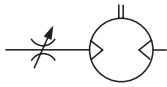

Supply or outlet throttling, nonreversible motor.

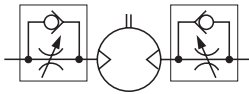

Supply throttling, reversible motor.

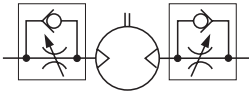

Outlet throttling, reversible motor.

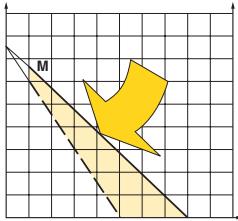

Torque curve change caused by throttling.

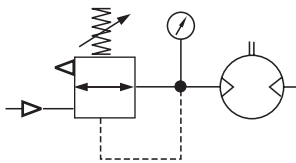

Pressure regulation at motor inlet.

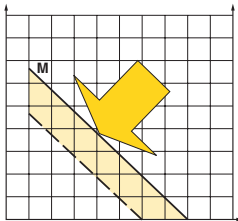

Torque curve change caused by pressure change.

The most common way to reduce the speed of a motor is to install a flow control in the air inlet. When the motor is used in applications where it must reverse and it is necessary to restrict the speed in both directions, flow controls with integral non-return function should be used in both directions.

Restriction may also be applied to the main outlet which will control the speed in both directions.

Inlet throttling

If the inlet air is restricted, the air supply is restricted and the free speed of the motor falls, but there is full pressure on the vanes at low speeds. This means full torque is available from the motor at low speed, despite the low air flow.

Since the torque curve becomes "steeper", this also means that we get a lower torque at any given speed than would be developed at full air flow.

Pressure regulation

The speed and torque can also be regulated by installing a pressure regulator in the inlet pipe. When the motor is constantly supplied with air at lower pressure and the motor is braked, it develops a lower torque on the output shaft.

In brief: *Inlet throttling* gives reduced speed in one direction but maintains torque when braked. *The torque curve becomes steeper.* A restriction in the main inlet gives reduced speed in both directions but maintains torque when braked. *The torque curve becomes steeper.* Pressure regulation in the inlet cuts torque when the motor is braked, and also reduces speed. *The torque curve is moved parallel.*

Air supply

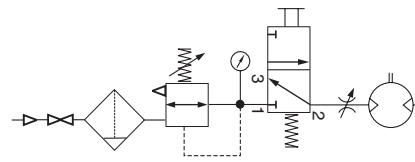

Shut-off, filtering, pressure regulation and control valve

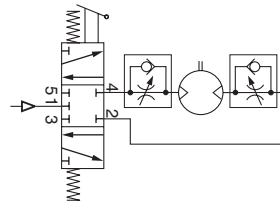

Reversible motor with 5/3 control valve

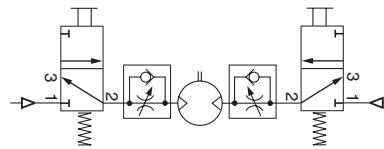

Reversible motor with two 3/2 control valves

The air supplying the motor must be filtered and regulated. Directional valves are needed to control the pressurized air which will cause the motor to rotate. These valves can be equipped with several means of actuation, such as electric, manual or pneumatic control. When the motor is used in a non-reversible application, it is sufficient to use a 2/2 or 3/2 valve for supply. Either one 5/3 or two 3/2 valves are needed for a reversible motor, to ensure that the motor gets its compressed air and the exhaust is vented. A flow control can be installed in the inlet pipe to regulate the motor speed if the motor is not used as a reversible motor. One flow control with by-pass is needed to regulate each direction of rotation if the motor is used as a reversible motor. The built-in check valve will then allow air from the exhaust to escape through the outlet port in the control valve.

The compressed air supply must have sufficiently large pipes and valves to give the motor maximum power. The motor needs 5 bar at the supply port all the time. A reduction of pressure to 4 bar reduces the power developed to 73%, and to 48% at 3 bar.

Choice of components for air supply

Since the supply pressure at the air motor inlet port is of considerable importance for obtaining the power, speed and torque quoted in the catalogue, the recommendations below should be observed.

The following data must be complied with:

Supply pressure to air treatment unit: Min 7,5 bar
 Gauge pressure: 6,7 bar
 Pipe length between air treatment unit and valve: Max 1 m
 Pipe length between valve and air motor: Max 2 m
 The pressure drop through air treatment unit - pipe - valve - pipe means that 5 bar pressure is obtained at the motor inlet port.

Please refer to the correction diagram on page 7, which shows what lower supply pressure means for power, speed and torque.

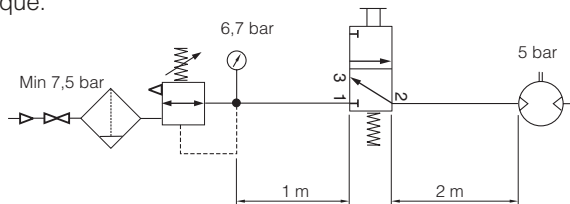

The table can be used as follows:

If you are using only one motor with each air treatment unit and valve, simply follow the table. If you are using more than one motor with the same air treatment unit: read the table values for selecting the air treatment unit and add them together, and select a suitable air treatment unit from the table showing air flows per treatment unit. Then read the values for selecting the valve from the bottom of the table, and select a suitable valve from the table showing air flows per valve family.

The air treatment units have the following flows in NI/Min at 7,5 bar supply pressure and 0,8 bar pressure drop

FRL series	Air flow in NI/Min
P3H, Moduflex FRL, 40 Series, G1/4	550
P3K, Moduflex FRL, 60 Series, G1/2	1310
P3M, Moduflex FRL, 80 Series, G1	2770
Standard series FRL, G11/2	9200
Stainless series FRL PF, G1/4	530
Stainless series FRL PF, G1/2	1480

Valve series with respective flows in NI/minute

Valve series	Qn in NI/Min
Valvetronic Solstar	33
Interface PS1	100
Adex A05	173
Moduflex size 1, (2 x 3/2)	220
Valvetronic PVL-B 5/3 closed centre, 6 mm push in	290
Moduflex size 1, (4/2)	320
B43 Manual and mechanical	340
Valvetronic PVL-B 2 x 2/3, 6 mm push in	350
Valvetronic PVL-B 5/3 closed centre, G1/8	370
Compact Isomax DX02	385
Valvetronic PVL-B 2 x 3/2 G1/8	440
Valvetronic PVL-B 5/2, 6 mm push in	450
Valvetronic PVL-B 5/3 vented centre, 6 mm push in	450
Moduflex size 2, (2 x 3/2)	450
Flowstar P2V-A	520
Valvetronic PVL-B 5/3 vented centre, G1/8	540
Valvetronic PVL-B 5/2, G1/8	540
Valvetronic PVL-C 2 x 3/2, 8 mm push in	540
Adex A12	560
Valvetronic PVL-C 2 x 3/2 G1/8	570
Compact Isomax DX01	585
VIKING Xtreme P2LAX	660
Valvetronic PVL-C 5/3 closed centre, 8 mm push in	700
Valvetronic PVL-C 5/3 vented centre, G1/4	700
B3-Series	780
Valvetronic PVL-C 5/3 closed centre, G1/4	780
Moduflex size 2, (4/2)	800
Valvetronic PVL-C 5/2, 8 mm push in	840
Valvetronic PVL-C 5/3 vented centre, 8 mm push in	840
Valvetronic PVL-C 5/2, G1/4	840
Flowstar P2V-B	1090
ISOMAX DX1	1150
B53 Manual and mechanical	1160
B4-Series	1170
VIKING Xtreme P2LBX	1290
B5-Series, G1/4	1440
Airline Isolator Valve VE22/23	1470
ISOMAX DX2	2330
VIKING Xtreme P2LCX, G3/8	2460
VIKING Xtreme P2LDX, G1/2	2660
ISOMAX DX3	4050
Airline Isolator Valve VE42/43	5520
Airline Isolator Valve VE82/83	13680

Air motors

Air motor	P1V-P007	P1V-P012	P1V-P023
Air flow required, NI/s	3,34	4,34	6,67
Air flow required, NI/min	200	260	400
Min. internal diameter of pipe, mm	6	10	10
Choice of air treatment unit: recommended min. air flow in litres/minute at 7,5 bar air supply and 0,8 bar pressure drop			
	150		
		210	
			300
Choice of valve: recommended min. air flow in Qn in litres/minute (Qn is the flow through the valve at 6 bar supply pressure and 1 bar pressure drop over the valve).			
	200		
		260	
			400

Silencing

Outlet silencer

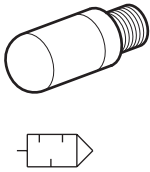

Central silencer

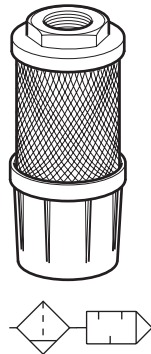

The noise from an air motor consists of both mechanical noise and a pulsating noise from the air flowing out of the outlet. The installation of the motor has a considerable effect on mechanical noise. It should be installed so that no mechanical resonance effects occur. The outlet air creates a noise level which can amount to 100 dB(A) if the air is allowed to exhaust freely into the atmosphere. To reduce noise levels, various types of outlet silencer are used. The most common type screws directly into the outlet port of the motor. A wide range of silencers are available. Many are made of sintered brass or sintered plastic. Since the motor function causes the exhaust air to pulsate, it is a good idea to allow the air to exhaust into some kind of chamber first, which reduces the pulsations before they reach the silencer. The best silencing method is to connect a soft hose to a central silencer allowing the speed of the air to reduce as much as possible.

NOTE! Remember that if a silencer is too small or is blocked, back pressure is generated on the outlet side of the motor, which in turn reduces the motor power.

Sound levels

Sound levels are measured at free speed with the measuring instrument positioned 1 m away from the air motor, see the table below

Air motor	Free outlet	With outlet silencer	Exhaust air removed with pipes to another room
	dB (A)	dB (A)	
P1V-P007	95	75	69
P1V-P012	100	80	72
P1V-P023	100	80	72

Compressed air quality

To get the very best reliability of service and longest service life on the P1VP motor with a minimum of environment influence is it necessary to fulfil following points

- The motor has to be supplied with clean compressed air
- The motor has to be supplied with dry compressed air
- The motor has to be supplied with lubricated compressed air

All exhaust air has to be taken away to central silencer to get the sound level down and to reduce the amount of dangerous oil mist in the exhaust air to a minimum. Oil and oil mist are things which one tries to avoid, to ensure clean working environment.

Working pressure :	Max 5 bar
Working temperature :	-10 to +70 °C
Medium :	Min 40 µm filtered, oil mist compressed air

Dry lubricated compressed air



To get minimum of production disturbance and as long service intervals and total service life as possible is it necessary for you as user to supply the P1V-P Air Motors with dry, clean and lubricated compressed air.

As to the quantity of lubrication is 2 to 3 drops of oil/minute appropriate.

For indoor use, we recommend ISO8573-1 purity class 3.4.4. To achieve this, compressors must be fitted with aftercoolers, oil filters, refrigerant air dryers, air filters and lubricators.

For indoor/outdoor use, we recommend ISO8573-1 purity class 1.2.4. To achieve this, compressors must be fitted with aftercoolers, oil filters, adsorption dryers, dust filters and lubricators.

The following oils are recommended for use in the industry : Type ISO VG32 shall be used.

ISO 8573-1 purity classes

Quality class	Contaminants		Water max. pressure dew point (°C)	Oil max. concentration (mg/m³)
	particle size (µm)	max. concentration (mg/m³)		
1	0,1	0,1	-70	0,01
2	1	1	-40	0,1
3	5	5	-20	1,0
4	15	8	+3	5,0
5	40	10	+7	25
6	-	-	+10	-

For example: compressed air to purity class 3.4.4

This means a 5 µm filter (standard filter), dew point +3 °C (refrigerant cooled) and an oil concentration of 5,0 mg oil/m³.



If the motor is works with higher speed than the speed by max output power will the service life be shorten.

P1V-P Air Motors with brake

P1V-P Air Motors can be braked by closing the supply/exhaust air. This gives a brake torque corresponding the average start torque if piping distance between valve and motor is short. Air Motors with powerful brake is necessary if torque is applied from load side, P1V-P with built on brake can be used in those cases.

Features

1. Non-fase adjustment is available for torque as needed
2. Simple design with little trouble and long life
3. The design makes the complete motor with brake to get a low weight

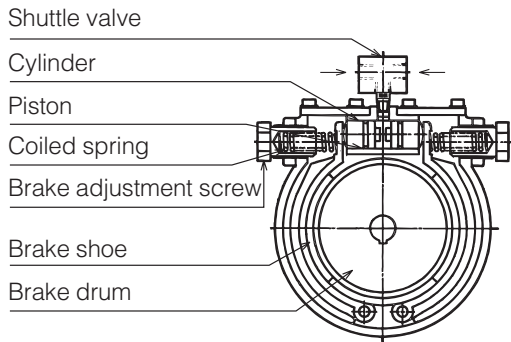

It is load-working type double lock air brake with brake force turned out by pushing force of coiled spring and release conducted by air pressure as usual. Brake shoe is opened from drum as piston for release works after air pressure is applied to supply port of air motor and simultaneously to brake cylinder.

When the rotation of motor is stopped and air pressure is exhausted, the air pressure of the brake cylinder is also exhausted instantly, and brake shoe is pushed to drum with pushing force of the coiled spring. The adjustment of brake torque is conducted with brake adjusting screw from the outside according to the necessary torque.

CE marking

The air motors are supplied as “Components for installation” – the installer is responsible for ensuring that the motors are installed safely in the overall system.

Parker Hannifin guarantees that its products are safe, and as a supplier of pneumatic equipment we ensure that the equipment is designed and manufactured in accordance with the applicable EU directive.

Most of our products are classed as components as defined by various directives, and although we guarantee that the components satisfy the fundamental safety requirements of the directives to the extent that they are our responsibility, they do not usually carry the CE mark.

The following are the currently applicable directives:

- Machinery Directive (essential health and safety requirements relating to the design and structure of machines and safety components)
- EMC Directive
- Simple Pressure Vessels Directive
- Low Voltage Directive
- ATEX Directive (ATEX = ATmosphere EXplosive)

Choice of air motor

Torque at maximum power [Nm]

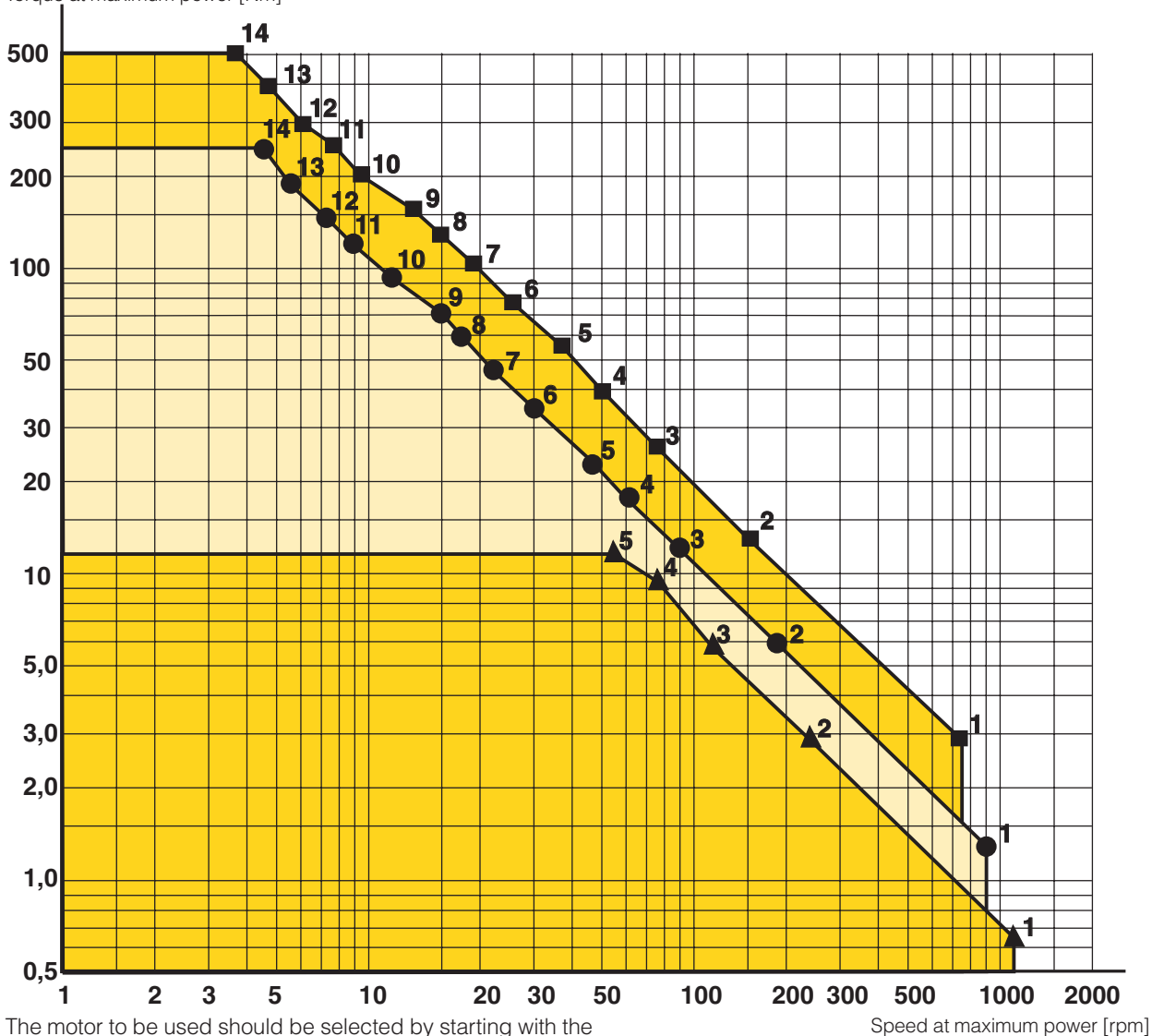

The motor to be used should be selected by starting with the torque needed at a specific shaft speed. In other words, to choose the right motor, you have to know the required speed and torque. Since maximum power is reached at half the motor's free speed, the motor should be chosen so that the operating point is as close as possible to the maximum power of the motor.

The design principle of the motor means that higher torque is generated when it is braked, which tends to increase the speed, etc. This means that the motor has a kind of speed self-regulation function built in.

Use the above graph to choose the correct motor size. The graph contains the points for the maximum torque of each motor at maximum output. Add your operating point to the graph, then select a marked point above and to the right of your point.

Then use the correct working diagram of the chosen motor to get more detailed technical data. Always select a motor whose requisite technical data are in the yellow area. Also use the correction diagram to find out what operation with different supply pressures would mean for the motor.

Tip: Select a motor which is slightly too fast and powerful, then regulate its speed and torque with a pressure regulator and/or throttle to achieve the optimum working point.

Air motors in diagram on page 12

- ▲ 1 Basic P1V-P007A02200, Flange P1V-P007B02200, Foot P1V-P007F02200
 - ▲ 2 Flange P1V-P007B00440, Foot P1V-P007F00440
 - ▲ 3 Flange P1V-P007B00220, Foot P1V-P007F00220
 - ▲ 4 Flange P1V-P007B00147, Foot P1V-P007F00147
 - ▲ 5 Flange P1V-P007B00110, Foot P1V-P007F00110
- Graphs for each motor, see page 17 and 22

P1V-P007



- 1 Basic P1V-P012A01800, Flange P1V-P012B01800, Foot P1V-P012F01800 or these as brake motors Basic P1V-P012AB1800, Flange P1V-P012BB1800, Foot P1V-P012FB1800
 - 2 Flange P1V-P012B00360, Foot P1V-P012F00360 or these as brake motors Flange P1V-P012BB0360, Foot P1V-P012FB0360
 - 3 Flange P1V-P012B00180, Foot P1V-P012F00180 or these as brake motors Flange P1V-P012BB0180, Foot P1V-P012FB0180
 - 4 Flange P1V-P012B00120, Foot P1V-P012F00120 or these as brake motors Flange P1V-P012BB0120, Foot P1V-P012FB0120
 - 5 Flange P1V-P012B00090, Foot P1V-P012F00090 or these as brake motors Flange P1V-P012BB0090, Foot P1V-P012FB0090
 - 6 Flange P1V-P012B00060, Foot P1V-P012F00060 or these as brake motors Flange P1V-P012BB0060, Foot P1V-P012FB0060
 - 7 Flange P1V-P012B00050, Foot P1V-P012F00050 or these as brake motors Flange P1V-P012BB0050, Foot P1V-P012FB0050
 - 8 Flange P1V-P012B00040, Foot P1V-P012F00040 or these as brake motors Flange P1V-P012BB0040, Foot P1V-P012FB0040
 - 9 Flange P1V-P012B00030, Foot P1V-P012F00030 or these as brake motors Flange P1V-P012BB0030, Foot P1V-P012FB0030
 - 10 Flange P1V-P012B00022, Foot P1V-P012F00022 or these as brake motors Flange P1V-P012BB0022, Foot P1V-P012FB0022
 - 11 Flange P1V-P012B00018, Foot P1V-P012F00018 or these as brake motors Flange P1V-P012BB0018, Foot P1V-P012FB0018
 - 12 Flange P1V-P012B00015, Foot P1V-P012F00015 or these as brake motors Flange P1V-P012BB0015, Foot P1V-P012FB0015
 - 13 Flange P1V-P012B00012, Foot P1V-P012F00012 or these as brake motors Flange P1V-P012BB0012, Foot P1V-P012FB0012
 - 14 Flange P1V-P012B00009, Foot P1V-P012F00009 or these as brake motors Flange P1V-P012BB0009, Foot P1V-P012FB0009
- Graphs for each motor, see page 17, 22 and 23

P1V-P012



- 1 Basic P1V-P023A01500, Flange P1V-P023B01500, Foot P1V-P023F01500 or these as brake motors Basic P1V-P023AB1500, Flange P1V-P023BB1500, Foot P1V-P023FB1500
 - 2 Flange P1V-P023B00300, Foot P1V-P023F00300 or these as brake motors Flange P1V-P023BB0300, Foot P1V-P023FB0300
 - 3 Flange P1V-P023B00150, Foot P1V-P023F00150 or these as brake motors Flange P1V-P023BB0150, Foot P1V-P023FB0150
 - 4 Flange P1V-P023B00050, Foot P1V-P023F00050 or these as brake motors Flange P1V-P023BB0100, Foot P1V-P023FB0100
 - 5 Flange P1V-P023B00075, Foot P1V-P023F00075 or these as brake motors Flange P1V-P023BB0075, Foot P1V-P023FB0075
 - 6 Flange P1V-P023B00050, Foot P1V-P023F00050 or these as brake motors Flange P1V-P023BB0050, Foot P1V-P023FB0050
 - 7 Flange P1V-P023B00038, Foot P1V-P023F00038 or these as brake motors Flange P1V-P023BB0038, Foot P1V-P023FB0038
 - 8 Flange P1V-P023B00030, Foot P1V-P023F00030 or these as brake motors Flange P1V-P023BB0030, Foot P1V-P023FB0030
 - 9 Flange P1V-P023B00025, Foot P1V-P023F00025 or these as brake motors Flange P1V-P023BB0025, Foot P1V-P023FB0025
 - 10 Flange P1V-P023B00018, Foot P1V-P023F00018 or these as brake motors Flange P1V-P023BB0018, Foot P1V-P023FB0018
 - 11 Flange P1V-P023B00015, Foot P1V-P023F00015 or these as brake motors Flange P1V-P023BB0015, Foot P1V-P023FB0015
 - 12 Flange P1V-P023B00012, Foot P1V-P023F00012 or these as brake motors Flange P1V-P023BB0012, Foot P1V-P023FB0012
 - 13 Flange P1V-P023B00009, Foot P1V-P023F00009 or these as brake motors Flange P1V-P023BB0009, Foot P1V-P023FB0009
 - 14 Flange P1V-P023B00007, Foot P1V-P023F00007 or these as brake motors Flange P1V-P023BB0007, Foot P1V-P023FB0007
- Graphs for each motor, see page 17, 22 and 23

P1V-P023

Technical data

Working pressure	Max 6 bar
Working temperature	-10 °C to +70 °C
Medium	Oil mist, dry compressed air purity class 3.4.4 according to ISO8573-1
Gearboxes	Grease lubricated

Table and diagram data

All values are typical values, with a tolerance of ±10%

Material specification

Nr	Designation	Material	Qty.
1	housing	Aluminium alloy casting	1
2	Cylinder cover	Aluminium alloy die-casting	3(5)
3	End cover	Synthetic resin	1
4	Connection rod	Aluminium alloy die-casting	3(5)
5	Piston	Brass casting	3(5)
6	Sleeve	Grey cast iron	3(5)
7	Piston pin	Carbon steel	3(5)
8	Ring	Carbon steel	2
9	Thrust washer	Carbon steel	2
10	Crank pin	Chromium-Molybdenum steel	1
11	Valve bush	Grey cast iron	1
12	Balance weight	Carbon steel	1
13	Shaft	Chrome-Molybdenum steel	1
14	Liner	Synthetic resin	3(5)
15	Bearing	-	1
16	Bearing	-	1
17	Needle bearing	-	1
18	Snap ring	-	1
19	Snap ring	-	1
20	Grease nipple	-	1
21	Copper rivet	-	6(10)
22	Oil seal	Nitrile rubber	1
23	O-ring	Nitrile rubber	3(5)
24	O-ring	Nitrile rubber	3(5)
25	O-ring	Nitrile rubber	3(5)
26	Parallel single key	-	1
27	Silencer	-	1
28	Adapter to G-thread	Aluminium	2

P1V-P023

P1V-P007 and P1V-S012

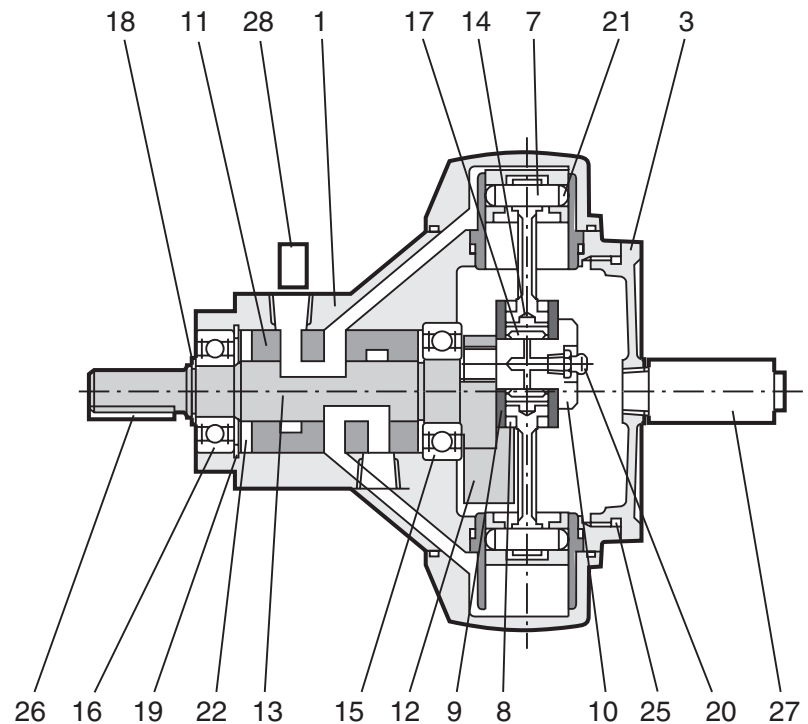
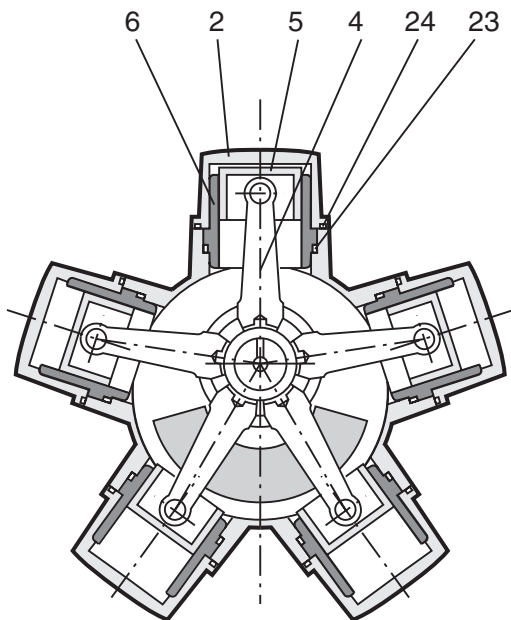

Order key

P	1	V	-	P
Motor size				
007	74 W			
012	125 W			
023	228 W			

0	1	2
Function		
A	Basic motor	
B	Flange version	
F	Foot version	

B	
Function	
0	Standard
B	Brake

0	0	6	0
Free speed/min			
2200	2200		
-	-		
0007	7		

P1V-P	Air motor range
P1V-P	Radial piston motor

Possible combinations

Please refer to pages 16 to 30.

Data för:

Reversible basic motor
 Reversible basic motor with flange
 Reversible basic motor with foot
 page 16



Reversible basic motor with brake
 Reversible basic motor with brake and flange
 Reversible basic motor with brake and foot
 page 17



Reversible motor with gearbox and flange, page 18
 Reversible motor with gearbox and foot, page 19



Reversible motor with gearbox, brake and flange, page 20
 Reversible motor with gearbox, brake and foot, page 21



NOTE! All technical data is based on a working pressure of 5 bar.

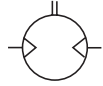

Data for reversible basic motor

Max power at max power kW	Speed at max power rpm	Torque at max power Nm	Min start torque Nm	Stall torque Nm	Brake torque Nm	Air consumption at max power l/s	Conn.	Min pipe ID mm	Weight Kg	Order code
0,0735	1100	0,637	0,686	1,18	-	3,34	G1/4	6	1,45	P1V-P007A02200
0,125	900	1,37	1,96	2,94	-	4,34	G1/4	10	2,5	P1V-P012A01800
0,228	750	2,94	4,71	5,88	-	6,67	G3/8	10	4,6	P1V-P023A01500

Data for reversible basic motor with flange

Max power at max power kW	Speed at max power rpm	Torque at max power Nm	Min start torque Nm	Stall torque Nm	Brake torque Nm	Air consumption at max power l/s	Conn.	Min pipe ID mm	Weight Kg	Order code
0,0735	1100	0,637	0,686	1,18	-	3,34	G1/4	6	1,45	P1V-P007B02200
0,125	900	1,37	1,96	2,94	-	4,34	G1/4	10	2,5	P1V-P012B01800
0,228	750	2,94	4,71	5,88	-	6,67	G3/8	10	4,6	P1V-P023B01500

Data for reversible basic motor with foot

Max power at max power kW	Speed at max power rpm	Torque at max power Nm	Min start torque Nm	Stall torque Nm	Brake torque Nm	Air consumption at max power l/s	Conn.	Min pipe ID mm	Weight Kg	Order code
0,0735	1100	0,637	0,686	1,18	-	3,34	G1/4	6	1,45	P1V-P007F02200
0,125	900	1,37	1,96	2,94	-	4,34	G1/4	10	2,5	P1V-P012F01800
0,228	750	2,94	4,71	5,88	-	6,67	G3/8	10	4,6	P1V-P023F01500

NOTE! All technical data is based on a working pressure of 5 bar.

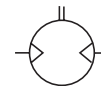

Data for reversible basic motor with brake

Max power at max power	Speed at max power	Torque at max power	Min start torque	Stall torque	Brake torque	Air consumption at max power	Conn.	Min pipe ID	Weight	Order code
kW	rpm	Nm	Nm	Nm	Nm	l/s		mm	Kg	
0,125	900	1,37	1,96	2,94	3,24	4,34	G1/4	10	4,4	P1V-P012AB1800
0,228	750	2,94	4,71	5,88	6,47	6,67	G3/8	10	7,8	P1V-P023AB1500

Data for reversible basic motor with brake and flange

Max power at max power	Speed at max power	Torque at max power	Min start torque	Stall torque	Brake torque	Air consumption at max power	Conn.	Min pipe ID	Weight	Order code
kW	rpm	Nm	Nm	Nm	Nm	l/s		mm	Kg	
0,125	900	1,37	1,96	2,94	3,24	4,34	G1/4	10	4,4	P1V-P012BB1800
0,228	750	2,94	4,71	5,88	6,47	6,67	G3/8	10	7,8	P1V-P023BB1500

Data for reversible basic motor with brake and foot

Max power at max power	Speed at max power	Torque at max power	Min start torque	Stall torque	Brake torque	Air consumption at max power	Conn.	Min pipe ID	Weight	Order code
kW	rpm	Nm	Nm	Nm	Nm	l/s		mm	Kg	
0,125	900	1,37	1,96	2,94	3,24	4,34	G1/4	10	5,2	P1V-P012FB1800
0,228	750	2,94	4,71	5,88	6,47	6,67	G3/8	10	9,4	P1V-P023FB1500

P1V-P007**2200

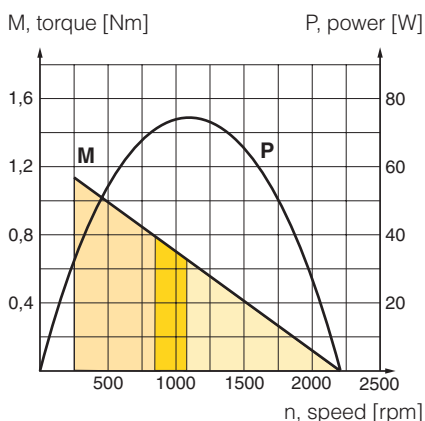

P1V-P012**1800

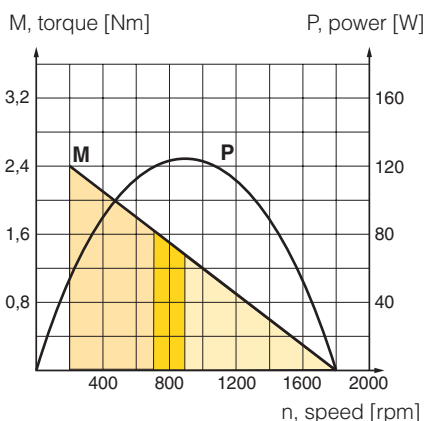

P1V-P023**1500

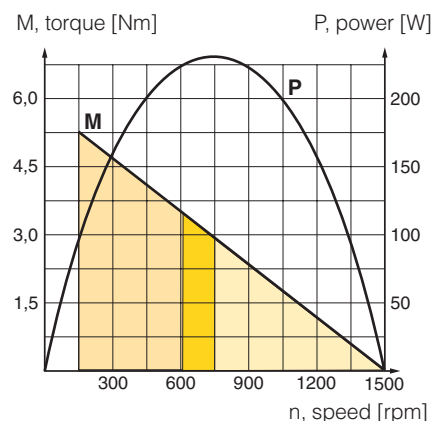

- Possible working range of motor.
- Optimum working range of motor.
- Working range with shorter service life.

Dimensions, see page 25-28
Permitted shaft loadings, see page 37

NOTE! All technical data is based on a working pressure of 5 bar.

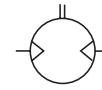

Data for reversible motor with gearbox and flange

Max power at max power kW	Speed at max power rpm	Torque at max power Nm	Min start torque Nm	Stall torque Nm	Brake torque Nm	Air consumption at max power l/s	Conn.	Min pipe ID mm	Weight Kg	Order code
0,0662	220	2,84	2,94	4,90	-	3,34	G1/4	6	4,0	P1V-P007B00440
0,0662	110	5,69	5,88	9,81	-	3,34	G1/4	6	4,0	P1V-P007B00220
0,0662	73,3	8,53	8,83	15,7	-	3,34	G1/4	6	4,0	P1V-P007B00147
0,0662	55	11,5	11,8	20,6	-	3,34	G1/4	6	4,0	P1V-P007B00110
0,110	180	5,88	8,83	12,7	-	4,34	G1/4	10	6,7	P1V-P012B00360
0,110	90	11,8	17,7	26,5	-	4,34	G1/4	10	6,7	P1V-P012B00180
0,110	60	17,7	26,5	39,2	-	4,34	G1/4	10	6,7	P1V-P012B00120
0,110	45	23,5	35,3	53,0	-	4,34	G1/4	10	6,7	P1V-P012B00090
0,110	30	35,3	53,0	78,5	-	4,34	G1/4	10	8,7	P1V-P012B00060
0,110	22,5	47,1	70,6	106	-	4,34	G1/4	10	8,7	P1V-P012B00050
0,110	18	58,8	79,4	132	-	4,34	G1/4	10	8,7	P1V-P012B00040
0,110	15	70,6	106	157	-	4,34	G1/4	10	8,7	P1V-P012B00030
0,110	11,2	93,2	139	206	-	4,34	G1/4	10	8,7	P1V-P012B00022
0,103	9	118	175	250	-	4,34	G1/4	10	11,7	P1V-P012B00018
0,103	7,5	137	206	300	-	4,34	G1/4	10	11,7	P1V-P012B00015
0,103	5,6	176	261	373	-	4,34	G1/4	10	11,7	P1V-P012B00012
0,103	4,5	233	350	500	-	4,34	G1/4	10	11,7	P1V-P012B00009
0,199	150	12,7	20,6	26,5	-	6,67	G3/8	10	10,5	P1V-P023B00300
0,199	75	26,5	41,2	53,0	-	6,67	G3/8	10	10,5	P1V-P023B00150
0,199	50	39,2	61,8	79,4	-	6,67	G3/8	10	10,5	P1V-P023B00100
0,199	37,5	53,0	82,4	106	-	6,67	G3/8	10	10,5	P1V-P023B00075
0,199	25	78,5	124	159	-	6,67	G3/8	10	14,0	P1V-P023B00050
0,199	18,7	106	165	212	-	6,67	G3/8	10	14,0	P1V-P023B00038
0,199	15	132	206	265	-	6,67	G3/8	10	14,0	P1V-P023B00030
0,199	12,5	157	247	318	-	6,67	G3/8	10	14,0	P1V-P023B00025
0,199	9,3	203	314	402	-	6,67	G3/8	10	14,0	P1V-P023B00018
0,191	7,5	250	392	490	-	6,67	G3/8	10	20,5	P1V-P023B00015
0,191	6,2	300	471	598	-	6,67	G3/8	10	20,5	P1V-P023B00012
0,191	4,6	396	628	785	-	6,67	G3/8	10	20,5	P1V-P023B00009
0,191	3,7	500	785	981	-	6,67	G3/8	10	20,5	P1V-P023B00007

Dimensions, see page 29-30

Permitted shaft loadings, see page 37

NOTE! All technical data is based on a working pressure of 5 bar.



Data for reversible motor with gearbox and foot

Max power kW	Speed at max power rpm	Torque at max power Nm	Min start torque Nm	Stall torque Nm	Brake torque Nm	Air consumption at max power l/s	Conn.	Min pipe ID mm	Weight Kg	Order code
0,0662	220	2,84	2,94	4,90	-	3,34	G1/4	6	3,5	P1V-P007F00440
0,0662	110	5,69	5,88	9,81	-	3,34	G1/4	6	4,0	P1V-P007F00220
0,0662	73,3	8,53	8,83	15,7	-	3,34	G1/4	6	3,5	P1V-P007F00147
0,0662	55	11,5	11,8	20,6	-	3,34	G1/4	6	3,5	P1V-P007F00110
0,110	180	5,88	8,83	12,7	-	4,34	G1/4	10	6,2	P1V-P012F00360
0,110	90	11,8	17,7	26,5	-	4,34	G1/4	10	6,2	P1V-P012F00180
0,110	60	17,7	26,5	39,2	-	4,34	G1/4	10	6,2	P1V-P012F00120
0,110	45	23,5	35,3	53,0	-	4,34	G1/4	10	6,2	P1V-P012F00090
0,110	30	35,3	53,0	78,5	-	4,34	G1/4	10	8,2	P1V-P012F00060
0,110	22,5	47,1	70,6	106	-	4,34	G1/4	10	8,2	P1V-P012F00050
0,110	18	58,8	79,4	132	-	4,34	G1/4	10	8,2	P1V-P012F00040
0,110	15	70,6	106	157	-	4,34	G1/4	10	8,2	P1V-P012F00030
0,110	11,2	93,2	139	206	-	4,34	G1/4	10	8,2	P1V-P012F00022
0,103	9	118	175	250	-	4,34	G1/4	10	11,2	P1V-P012F00018
0,103	7,5	137	206	300	-	4,34	G1/4	10	11,2	P1V-P012F00015
0,103	5,6	176	261	373	-	4,34	G1/4	10	11,2	P1V-P012F00012
0,103	4,5	233	350	500	-	4,34	G1/4	10	11,2	P1V-P012F00009
0,199	150	12,7	20,6	26,5	-	6,67	G3/8	10	10,0	P1V-P023F00300
0,199	75	26,5	41,2	53,0	-	6,67	G3/8	10	10,0	P1V-P023F00150
0,199	50	39,2	61,8	79,4	-	6,67	G3/8	10	10,0	P1V-P023F00100
0,199	37,5	53,0	82,4	106	-	6,67	G3/8	10	10,0	P1V-P023F00075
0,199	25	78,5	124	159	-	6,67	G3/8	10	13,5	P1V-P023F00050
0,199	18,7	106	165	212	-	6,67	G3/8	10	13,5	P1V-P023F00038
0,199	15	132	206	265	-	6,67	G3/8	10	13,5	P1V-P023F00030
0,199	12,5	157	247	318	-	6,67	G3/8	10	13,5	P1V-P023F00025
0,199	9,3	203	314	402	-	6,67	G3/8	10	13,5	P1V-P023F00018
0,191	7,5	250	392	490	-	6,67	G3/8	10	20,0	P1V-P023F00015
0,191	6,2	300	471	598	-	6,67	G3/8	10	20,0	P1V-P023F00012
0,191	4,6	396	628	785	-	6,67	G3/8	10	20,0	P1V-P023F00009
0,191	3,7	500	785	981	-	6,67	G3/8	10	20,0	P1V-P023F00007

Dimensions, see page 29-30

Permitted shaft loadings, see page 37

NOTE! All technical data is based on a working pressure of 5 bar.



Data for reversible motor with gearbox, brake and flange

Max power kW	Speed at max power rpm	Torque at max power Nm	Min start torque Nm	Stall torque Nm	Brake torque Nm	Air consumption at max power l/s	Conn.	Min pipe ID mm	Weight Kg	Order code
0,110	180	5,88	8,83	12,7	14,7	4,34	G1/4	10	8,0	P1V-P012BB0360
0,110	90	11,8	17,7	26,5	29,4	4,34	G1/4	10	8,0	P1V-P012BB0180
0,110	60	17,7	26,5	39,2	44,1	4,34	G1/4	10	8,0	P1V-P012BB0120
0,110	45	23,5	35,3	53,0	58,8	4,34	G1/4	10	8,0	P1V-P012BB0090
0,110	30	35,3	53,0	78,5	88,3	4,34	G1/4	10	10,0	P1V-P012BB0060
0,110	22,5	47,1	70,6	106	118	4,34	G1/4	10	10,0	P1V-P012BB0050
0,110	18	58,8	79,4	132	147	4,34	G1/4	10	10,0	P1V-P012BB0040
0,110	15	70,6	106	157	177	4,34	G1/4	10	10,0	P1V-P012BB0030
0,110	11,2	93,2	139	206	235	4,34	G1/4	10	10,0	P1V-P012BB0022
0,103	9	118	175	250	283	4,34	G1/4	10	11,7	P1V-P012BB0018
0,103	7,5	137	206	300	339	4,34	G1/4	10	13,0	P1V-P012BB0015
0,103	5,6	176	261	373	453	4,34	G1/4	10	13,0	P1V-P012BB0012
0,103	4,5	233	350	500	567	4,34	G1/4	10	13,0	P1V-P012BB0009
0,199	150	12,7	20,6	26,5	29,4	6,67	G3/8	10	13,5	P1V-P023BB0300
0,199	75	26,5	41,2	53,0	58,8	6,67	G3/8	10	13,5	P1V-P023BB0150
0,199	50	39,2	61,8	79,4	88,3	6,67	G3/8	10	13,5	P1V-P023BB0100
0,199	37,5	53,0	82,4	106	118	6,67	G3/8	10	13,5	P1V-P023BB0075
0,199	25	78,5	124	159	177	6,67	G3/8	10	17,0	P1V-P023BB0050
0,199	18,7	106	165	212	235	6,67	G3/8	10	17,0	P1V-P023BB0038
0,199	15	132	206	265	294	6,67	G3/8	10	17,0	P1V-P023BB0030
0,199	12,5	157	247	318	353	6,67	G3/8	10	17,0	P1V-P023BB0025
0,199	9,3	203	314	402	471	6,67	G3/8	10	17,0	P1V-P023BB0018
0,191	7,5	250	392	490	549	6,67	G3/8	10	24,5	P1V-P023BB0015
0,191	6,2	300	471	598	657	6,67	G3/8	10	24,5	P1V-P023BB0012
0,191	4,6	396	628	785	873	6,67	G3/8	10	24,5	P1V-P023BB0009
0,191	3,7	500	785	981	1100	6,67	G3/8	10	24,5	P1V-P023BB0007

Dimensions, see page 31-32

Permitted shaft loadings, see page 37

NOTE! All technical data is based on a working pressure of 5 bar.

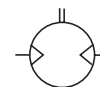

Data for reversible motor with gearbox, brake and foot

Max power kW	Speed at max power rpm	Torque at max power Nm	Min start torque Nm	Stall torque Nm	Brake torque Nm	Air consumption at max power l/s	Conn.	Min pipe ID mm	Weight Kg	Order code
0,110	180	5,88	8,83	12,7	14,7	4,34	G1/4	10	8,5	P1V-P012FB0360
0,110	90	11,8	17,7	26,5	29,4	4,34	G1/4	10	8,5	P1V-P012FB0180
0,110	60	17,7	26,5	39,2	44,1	4,34	G1/4	10	8,5	P1V-P012FB0120
0,110	45	23,5	35,3	53,0	58,8	4,34	G1/4	10	8,5	P1V-P012FB0090
0,110	30	35,3	53,0	78,5	88,3	4,34	G1/4	10	10,5	P1V-P012FB0060
0,110	22,5	47,1	70,6	106	118	4,34	G1/4	10	10,5	P1V-P012FB0050
0,110	18	58,8	79,4	132	147	4,34	G1/4	10	10,5	P1V-P012FB0040
0,110	15	70,6	106	157	177	4,34	G1/4	10	10,5	P1V-P012FB0030
0,110	11,2	93,2	139	206	235	4,34	G1/4	10	10,5	P1V-P012FB0022
0,103	9	118	175	250	283	4,34	G1/4	10	13,5	P1V-P012FB0018
0,103	7,5	137	206	300	339	4,34	G1/4	10	13,5	P1V-P012FB0015
0,103	5,6	176	261	373	453	4,34	G1/4	10	13,5	P1V-P012FB0012
0,103	4,5	233	350	500	567	4,34	G1/4	10	13,5	P1V-P012FB0009
0,199	150	12,7	20,6	26,5	29,4	6,67	G3/8	10	13,0	P1V-P023FB0300
0,199	75	26,5	41,2	53,0	58,8	6,67	G3/8	10	13,0	P1V-P023FB0150
0,199	50	39,2	61,8	79,4	88,3	6,67	G3/8	10	13,0	P1V-P023FB0100
0,199	37,5	53,0	82,4	106	118	6,67	G3/8	10	13,0	P1V-P023FB0075
0,199	25	78,5	124	159	177	6,67	G3/8	10	16,5	P1V-P023FB0050
0,199	18,7	106	165	212	235	6,67	G3/8	10	16,5	P1V-P023FB0038
0,199	15	132	206	265	294	6,67	G3/8	10	16,5	P1V-P023FB0030
0,199	12,5	157	247	318	353	6,67	G3/8	10	16,5	P1V-P023FB0025
0,199	9,3	203	314	402	471	6,67	G3/8	10	16,5	P1V-P023FB0018
0,191	7,5	250	392	490	549	6,67	G3/8	10	24,0	P1V-P023FB0015
0,191	6,2	300	471	598	657	6,67	G3/8	10	24,0	P1V-P023FB0012
0,191	4,6	396	628	785	873	6,67	G3/8	10	24,0	P1V-P023FB0009
0,191	3,7	500	785	981	1100	6,67	G3/8	10	24,0	P1V-P023FB0007

Dimensions, see page 31-32

Permitted shaft loadings, see page 37

P1V-P007**0440

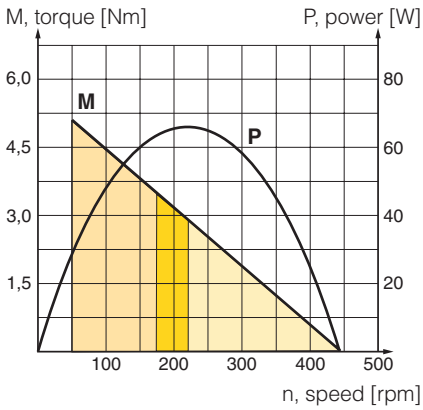

P1V-P007**0220

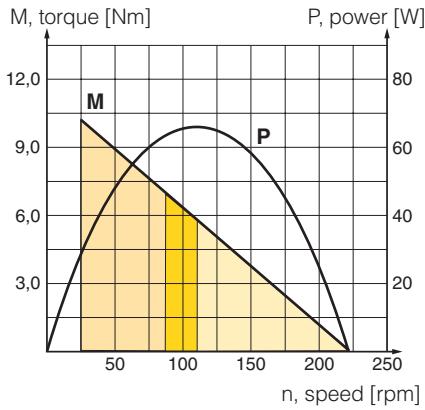

P1V-P007**0147

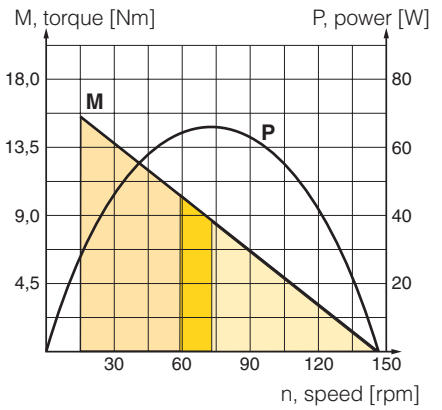

P1V-P007**0110

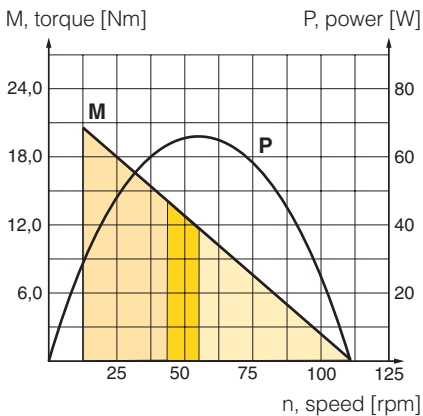

P1V-P012**0360

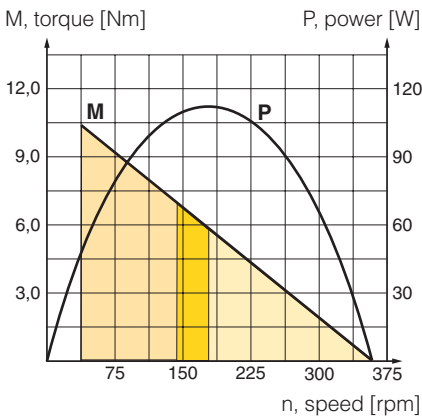

P1V-P012**0180

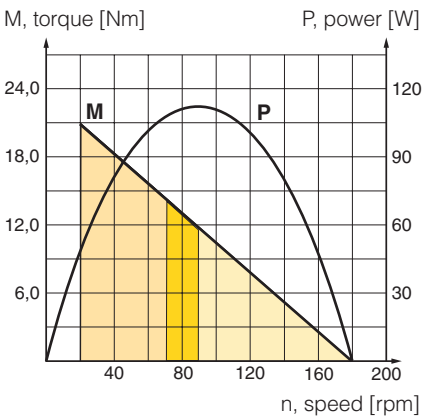

P1V-P012**0120

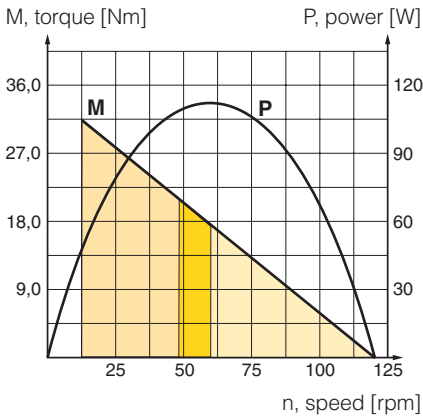

P1V-P012**0090

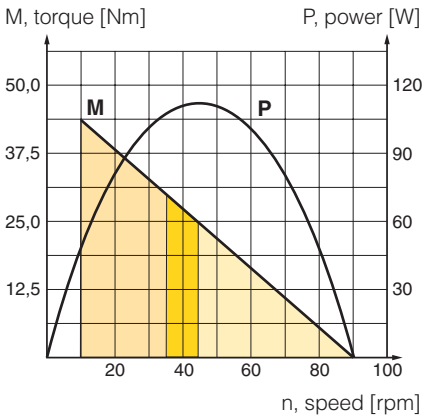

P1V-P012**0060

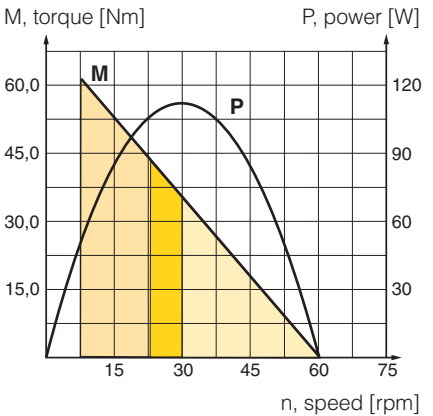

P1V-P012**0050

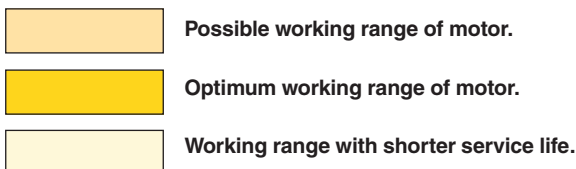
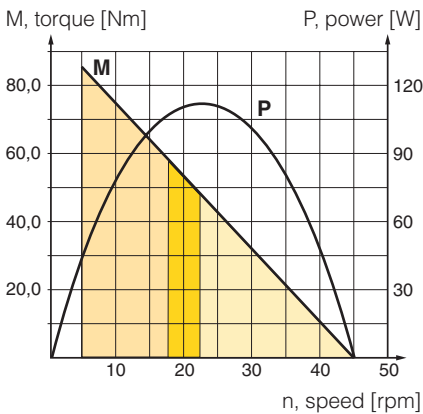

P1V-P0120040**

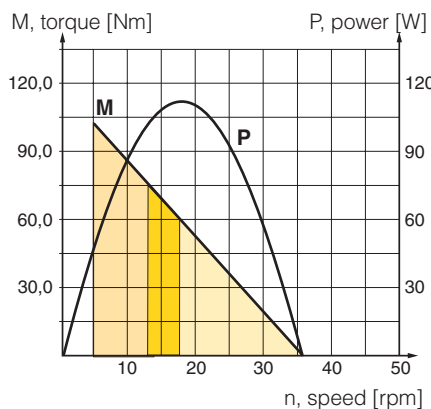

P1V-P0120030**

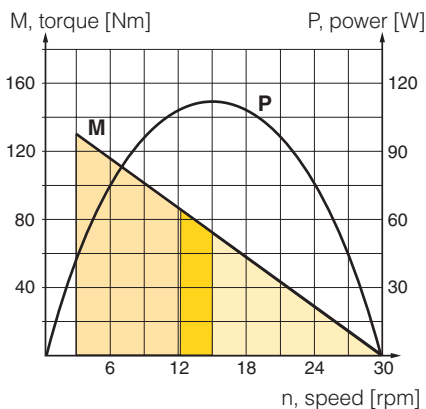

P1V-P0120022**

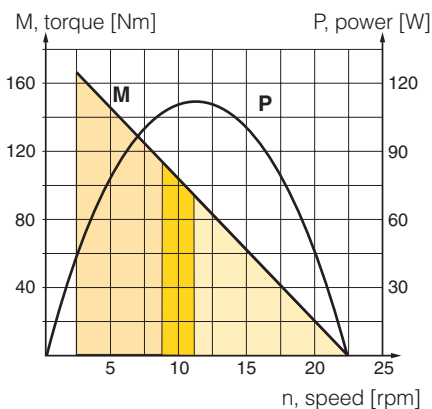

P1V-P0120018**

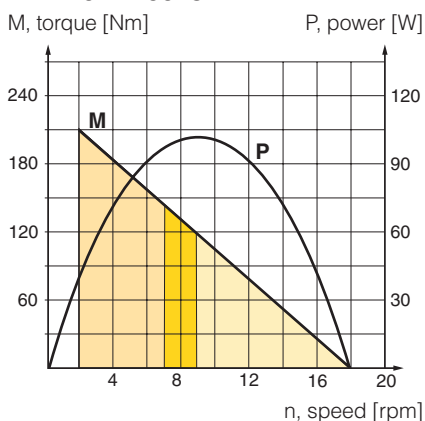

P1V-P0120015**

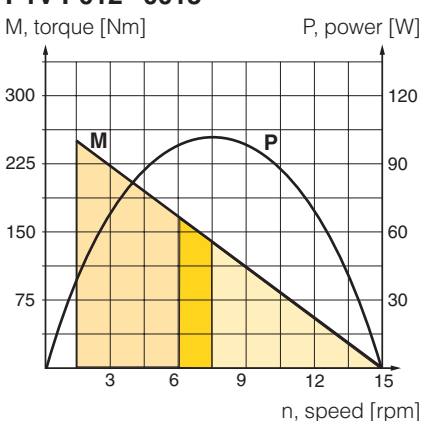

P1V-P0120012**

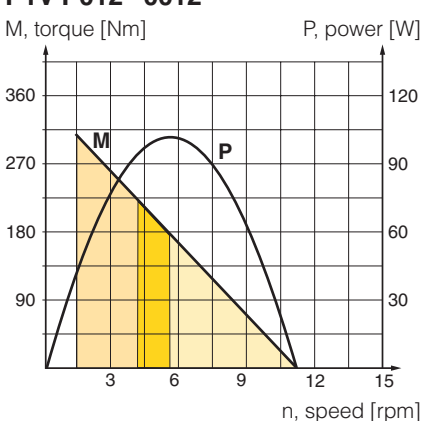

P1V-P0120009**

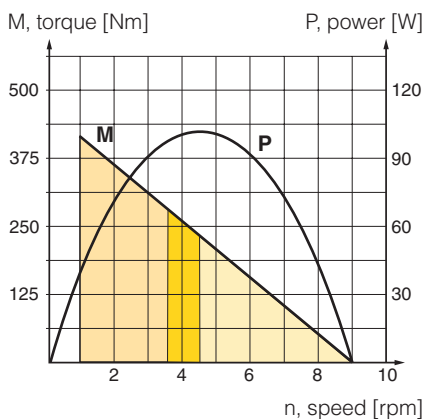

P1V-P0230300**

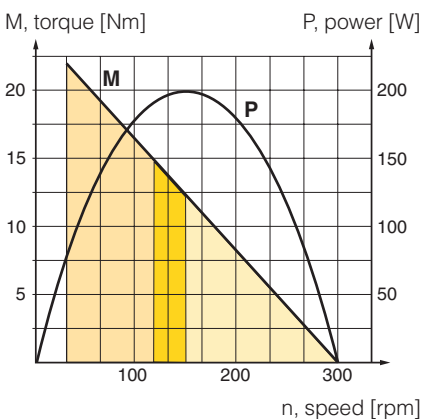

P1V-P0230150**

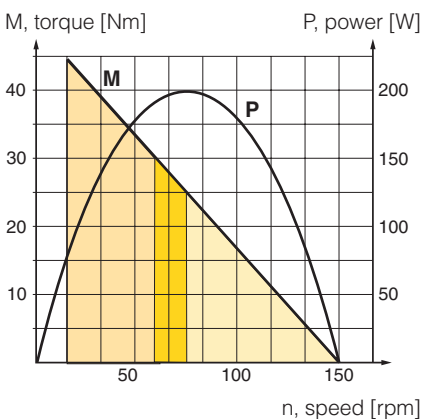

P1V-P0230100**

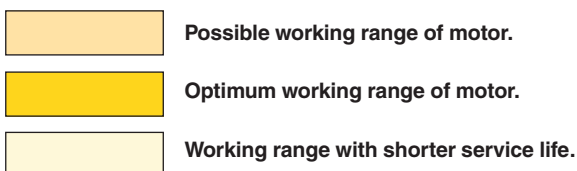
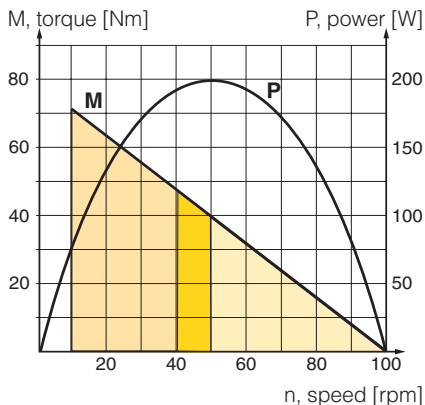

P1V-P0230075**

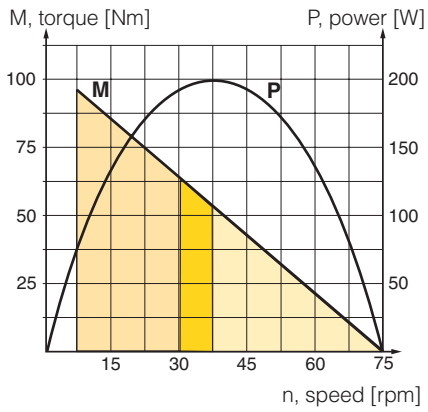

P1V-P0230050**

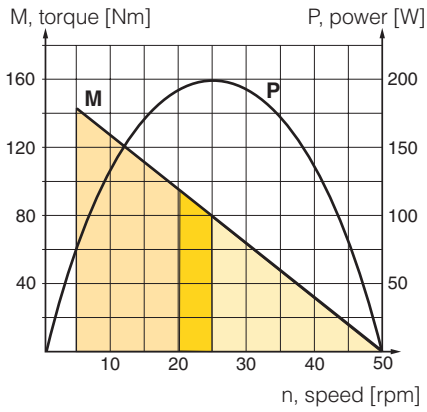

P1V-P0230038**

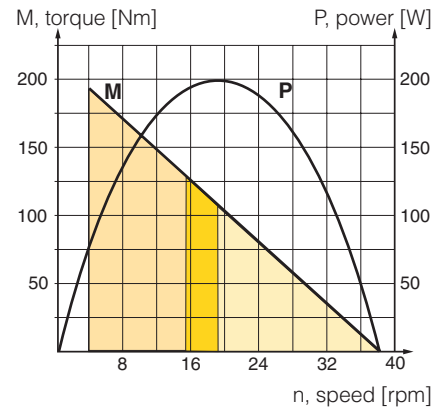

P1V-P0230030**

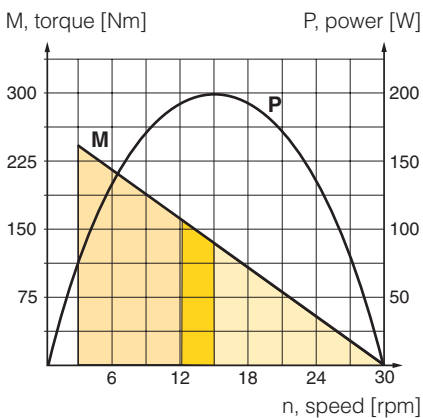

P1V-P0230025**

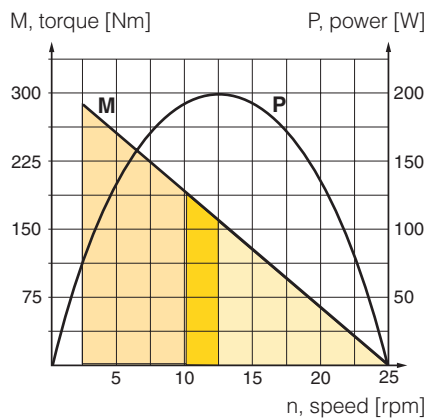

P1V-P0230018**

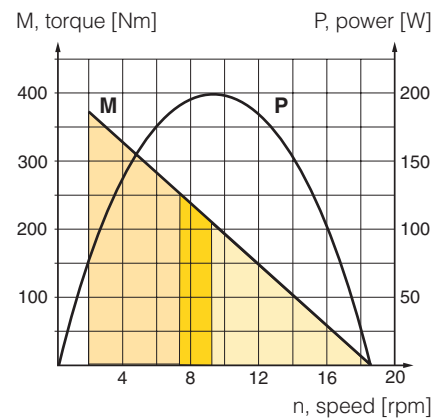

P1V-P0230015**

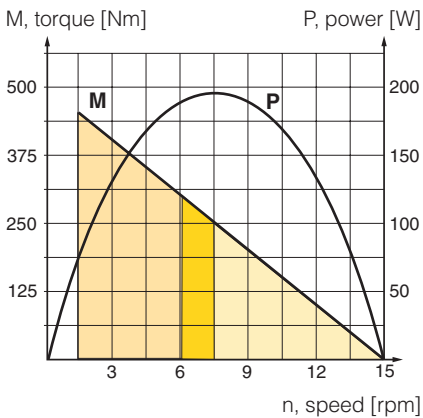

P1V-P0230012**

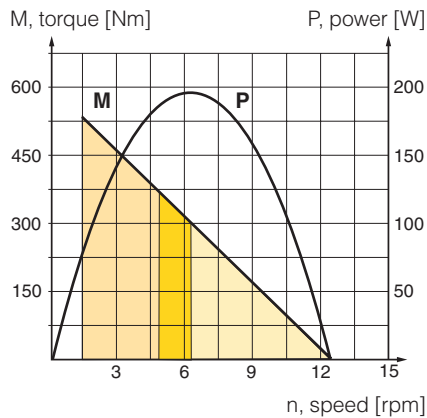

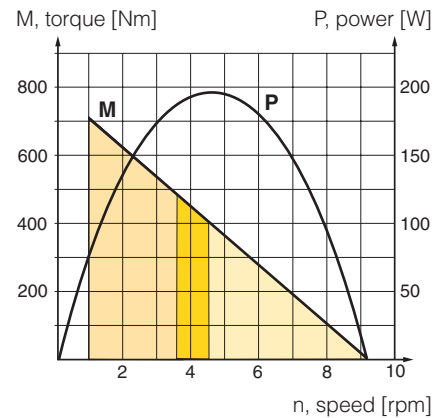

P1V-P0230009**

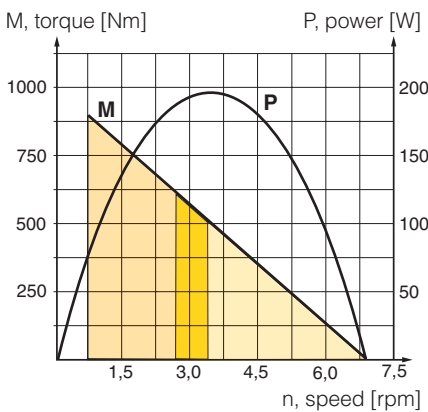

P1V-P0230007**

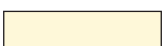

-  Possible working range of motor.
-  Optimum working range of motor.
-  Working range with shorter service life.

Reversible basic motor

P1V-P007A02200

P1V-P012A01800

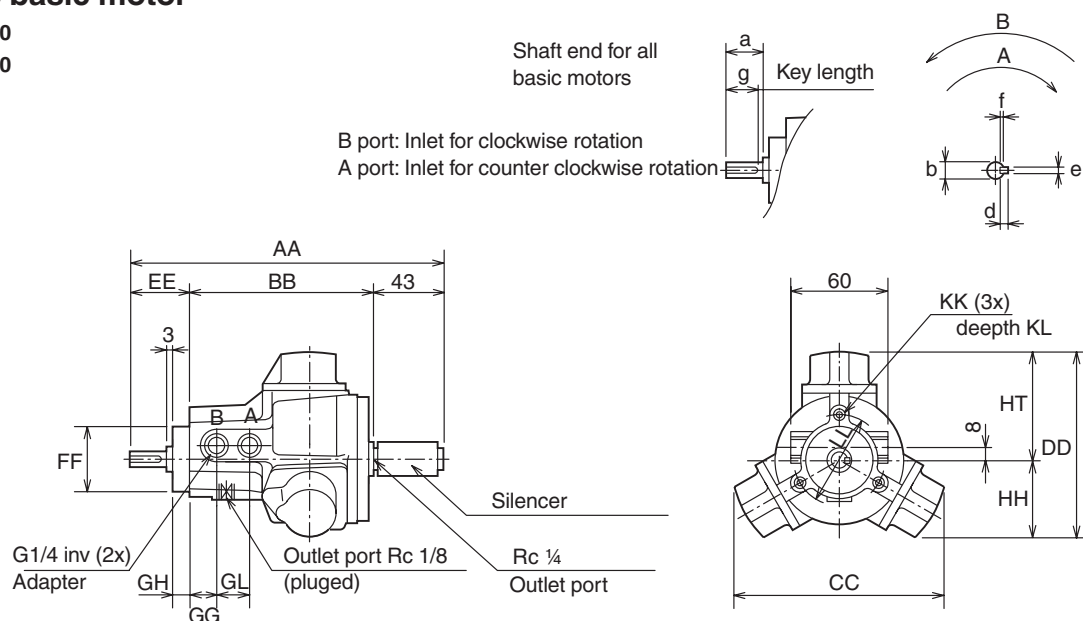

Reversible basic motor with flange

P1V-P007B02200

P1V-P012B01800

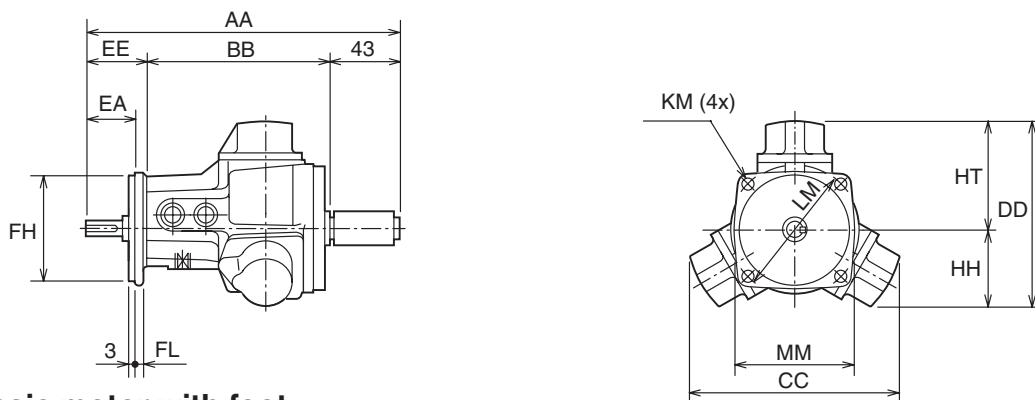

Reversible basic motor with foot

P1V-P007F02200

P1V-P012F01800

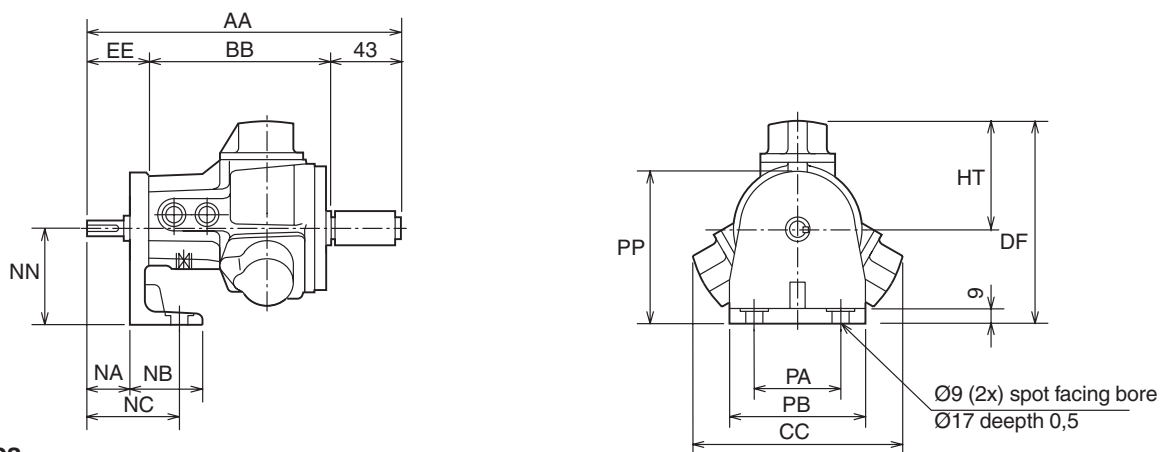

Dimension tables

Motor	AA	BB	CC	DD	DF	EA	EE	FF	FH	FL	GG	GH	GL	HH	HT	KK	KL	KM
P1V-P007*02200	192	113	130	115	127	29	36	∅42 h7	∅68 h7	5	17	10	20	48	67	M5x0,8	8	∅6
P1V-P012*01800	225	137	164	142	152	36	45	∅48 h7	∅78 h7	7	19	12	28	60	82	M6x1	12	∅7

Motor	LL	LM	MM	NA	NB	NC	NN	PA	PB	PP	Shaft end					
											a	b	d	e	f	g
P1V-P007*02200	∅55	∅80	72	26	45	56	60+/-0,1	50	80	94	23	∅10h6	3	3	1,8	20
P1V-P012*01800	∅62	∅92	86	33	50	63	70+/-0,1	70	100	110	30	∅12h6	4	4	2,5	27

Reversible basic motor

P1V-P023A01500

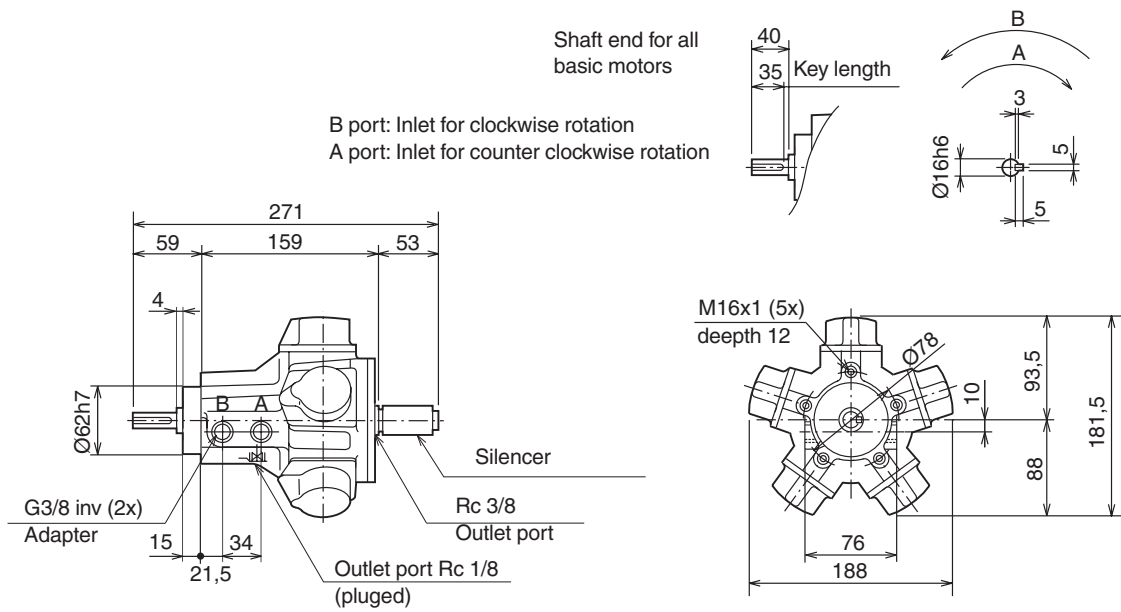

Reversible basic motor with flange

P1V-P023B01500

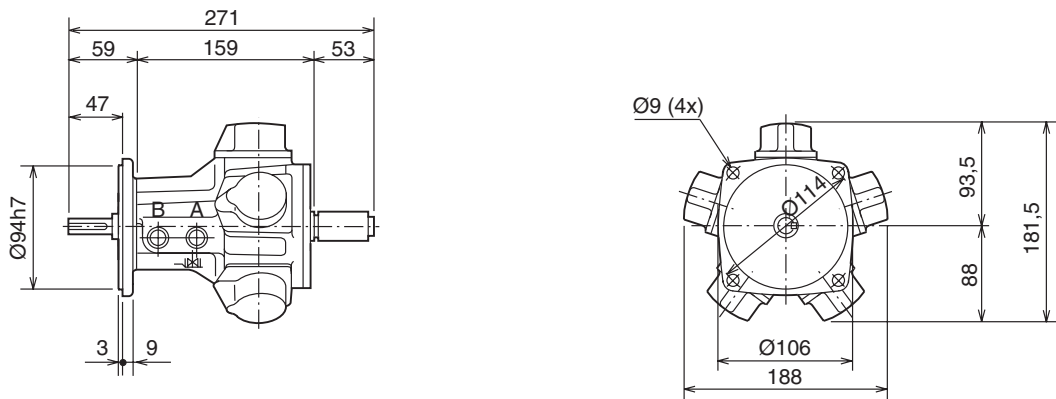

Reversible basic motor with foot

P1V-P023F01500

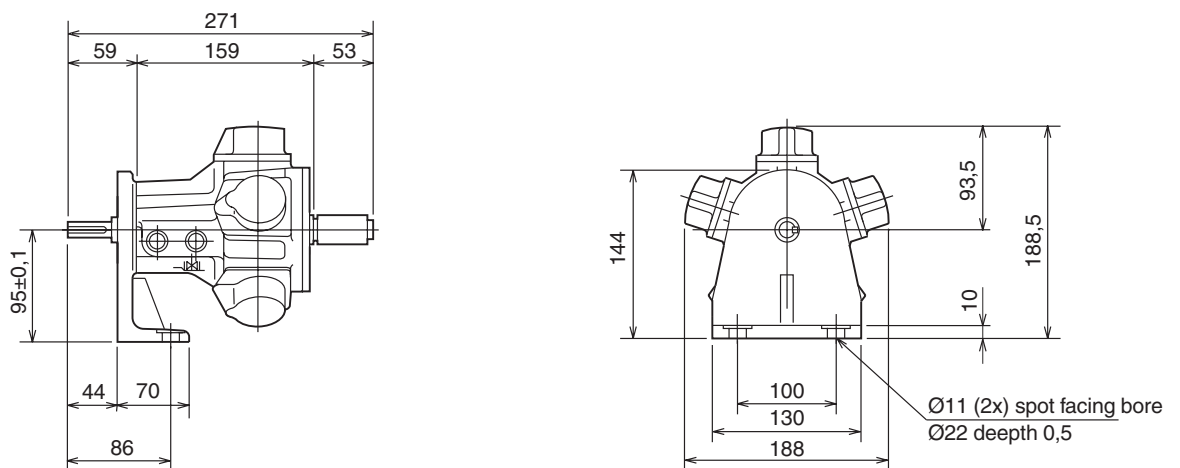

Reversible basic motor with brake

P1V-P012AB1800

Shaft end for all basic motors

B port: Inlet for clockwise rotation
A port: Inlet for counter clockwise rotation

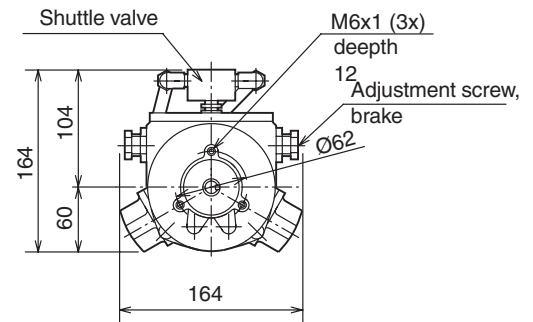
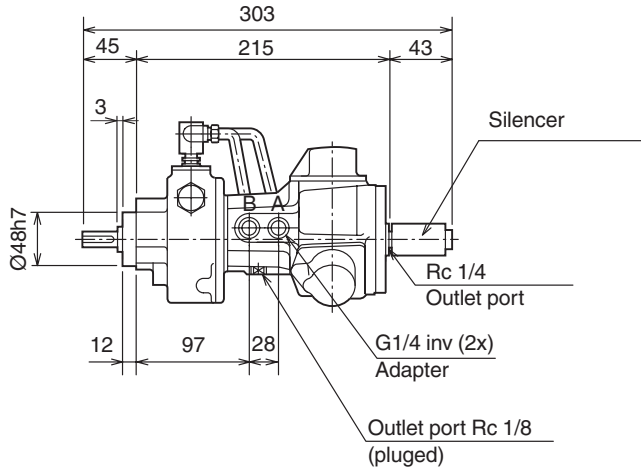
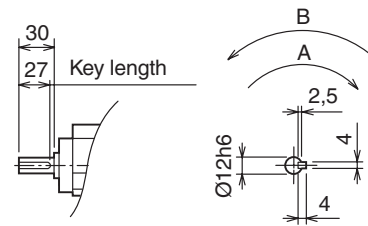

Reversible basic motor with brake and flange

P1V-P012BB1800

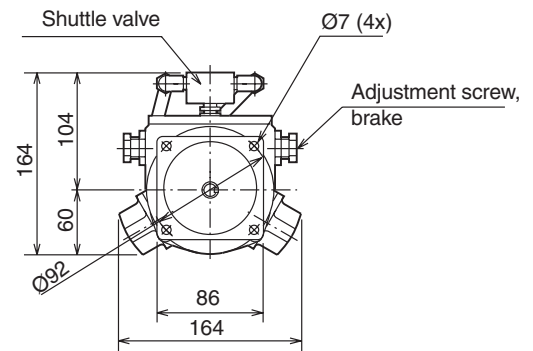
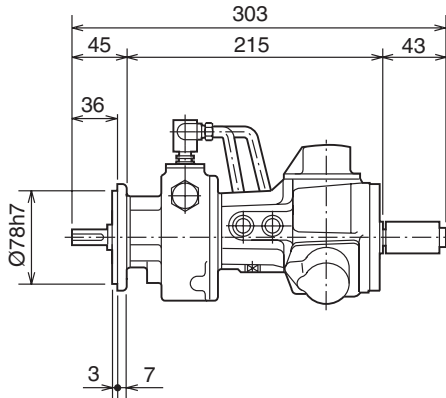

Reversible basic motor with brake and foot

P1V-P012FB1800

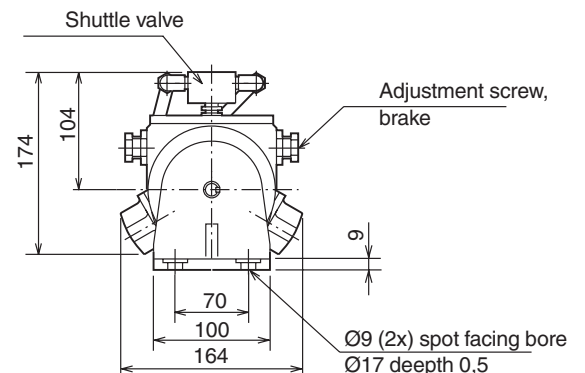
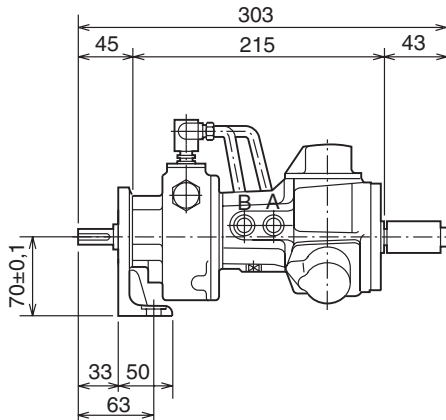

Reversible basic motor with brake

P1V-P023AB1500

Shaft end for all basic motors

B port: Inlet for clockwise rotation
A port: Inlet for counter clockwise rotation

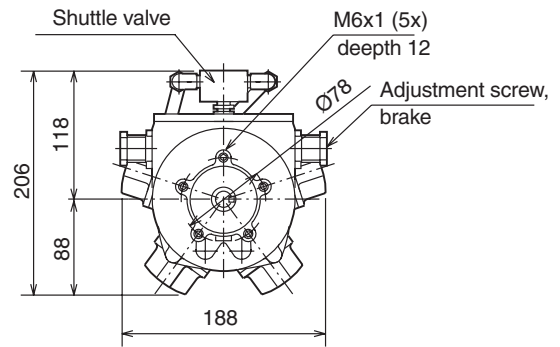
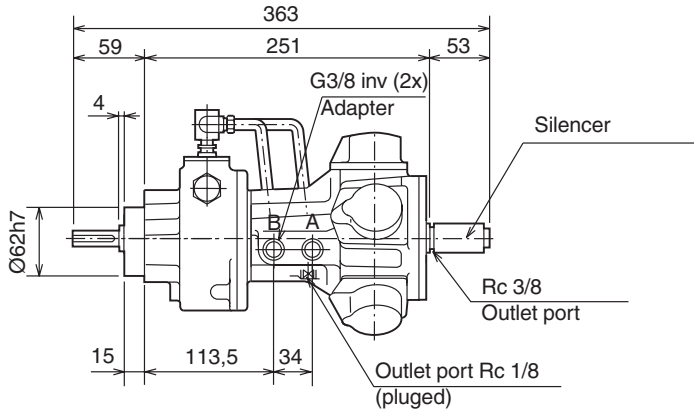
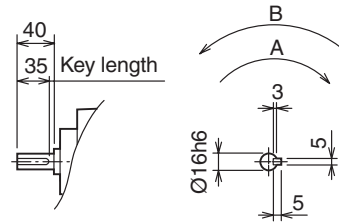

Reversible basic motor with brake and flange

P1V-P023BB1500

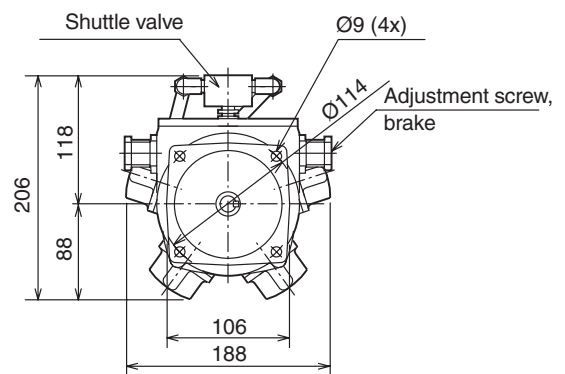
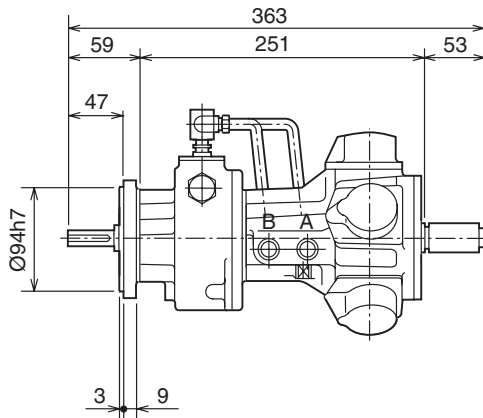

Reversible basic motor with brake and foot

P1V-P023FB1500

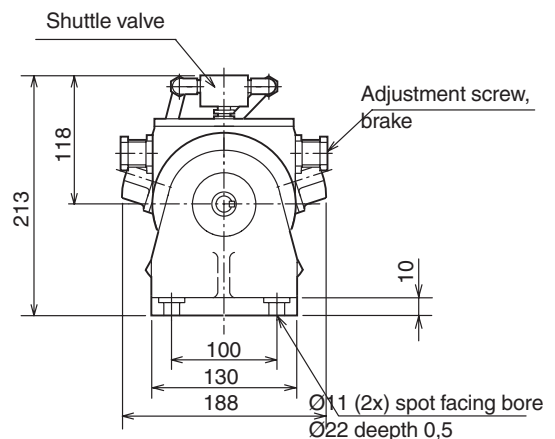
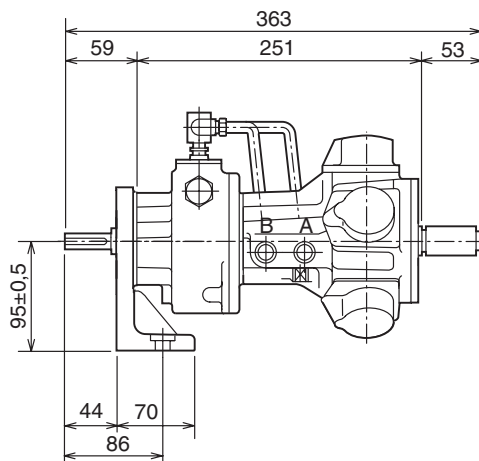

Reversible motor with gearbox and flange

- P1V-P007B00440
- P1V-P007B00220
- P1V-P007B00147
- P1V-P007B00110
- P1V-P012B00360
- P1V-P012B00180
- P1V-P012B00120
- P1V-P012B00090
- P1V-P012B00060
- P1V-P012B00050
- P1V-P012B00040
- P1V-P012B00030
- P1V-P012B00022
- P1V-P012B00018
- P1V-P012B00015
- P1V-P012B00012
- P1V-P012B00009

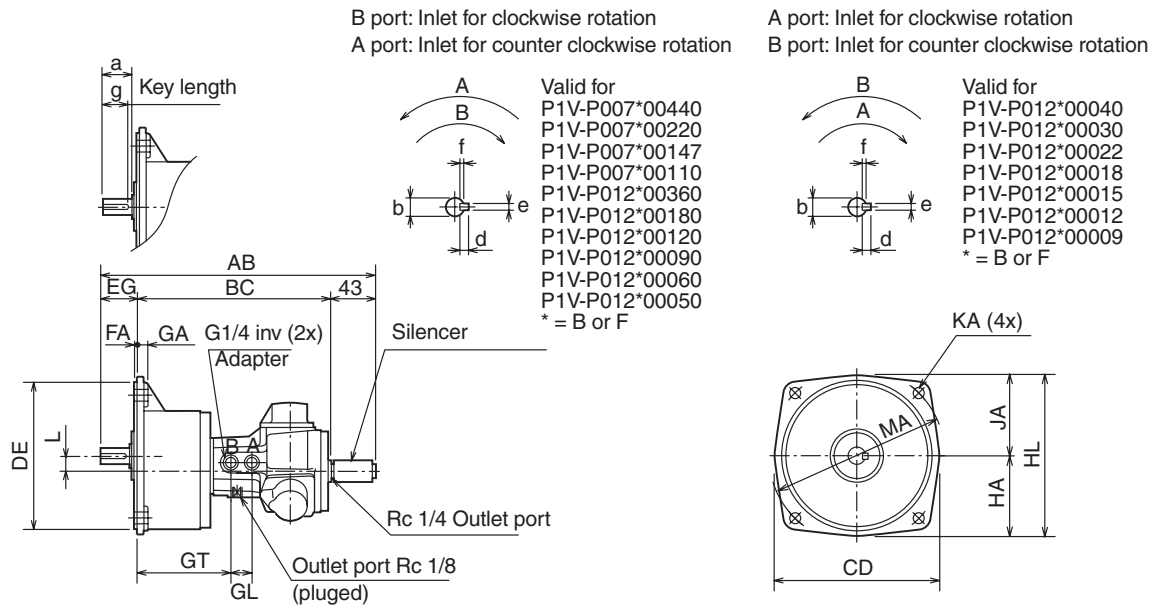

Reversible motor with gearbox and foot

- P1V-P007F00440
- P1V-P007F00220
- P1V-P007F00147
- P1V-P007F00110
- P1V-P012F00360
- P1V-P012F00180
- P1V-P012F00120
- P1V-P012F00090
- P1V-P012F00060
- P1V-P012F00050
- P1V-P012F00040
- P1V-P012F00030
- P1V-P012F00022
- P1V-P012F00018
- P1V-P012F00015
- P1V-P012F00012
- P1V-P012F00009

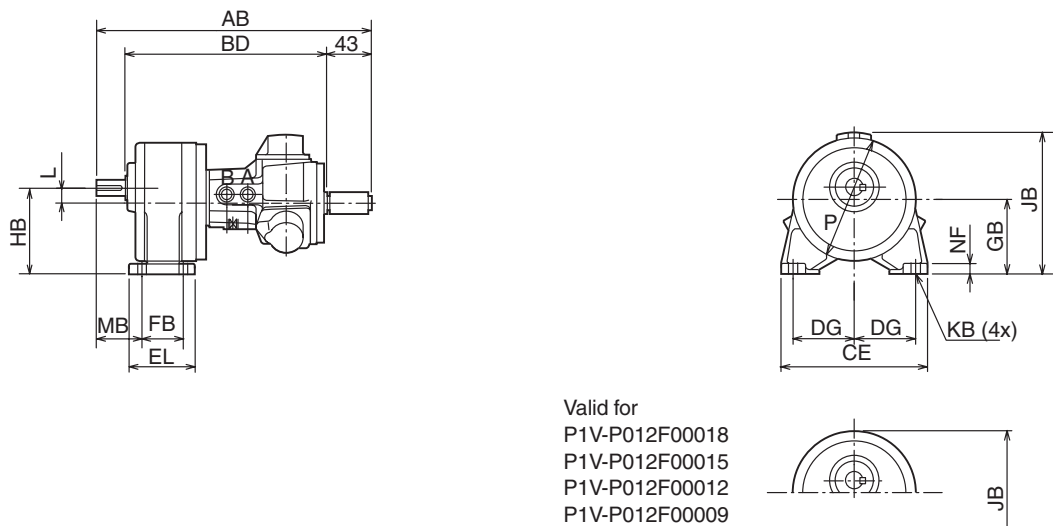

Dimension tables

Motor	AB	BC	BD	CD	CE	DE	DG	EG	EL	FA	FB	GA	GB	GL	GT	HA	HB	HL
P1V-P007*00440 P1V-P007*00220	272	194	199	154	134	∅145 h7	55	35	64	3	40	10	68,5	20	98	80,0	85	157,0
P1V-P012*00360 P1V-P012*00180	323	233	240	164	154	∅148 h7	65	47	90	4	65	12	71,0	28	115	89,0	90	171,5
P1V-P012*00060 P1V-P012*00050	340	247	252	186	175	∅170 h7	70	50	125	4	90	15	86,5	28	128	105,5	110	199,0
P1V-P012*00040 P1V-P012*00030	360	257	262	215	208	∅180 h7	85	60	168	4	130	15	101,5	28	139	126,5	130	234,0

Motor	JA	JB	KA	KB	L	MA	MB	NF	P	Shaft end					
										a	b	d	e	f	g
P1V-P007*00440 P1V-P007*00220	77,0	135,5	∅11	∅9	16,5	∅170	45	10	∅112	30	∅18h6	6	6	3,5	27
P1V-P012*00360 P1V-P012*00180	82,5	153,0	∅11	∅11	19,0	∅185	55	12	∅125	40	∅22h6	6	6	3,5	35
P1V-P012*00060 P1V-P012*00050	94,0	169,0	∅11	∅11	23,5	∅215	65	15	∅152	45	∅28h6	7	8	4	40
P1V-P012*00018 P1V-P012*00015	107,5	198,0	∅13	∅13	28,5	∅250	70	18	∅184	55	∅32h6	8	10	5	50

Reversible motor with gearbox and flange

- P1V-P023B00300
- P1V-P023B00150
- P1V-P023B00100
- P1V-P023B00075
- P1V-P023B00050
- P1V-P023B00038
- P1V-P023B00030
- P1V-P023B00025
- P1V-P023B00018
- P1V-P023B00015
- P1V-P023B00012
- P1V-P023B00009
- P1V-P023B00007

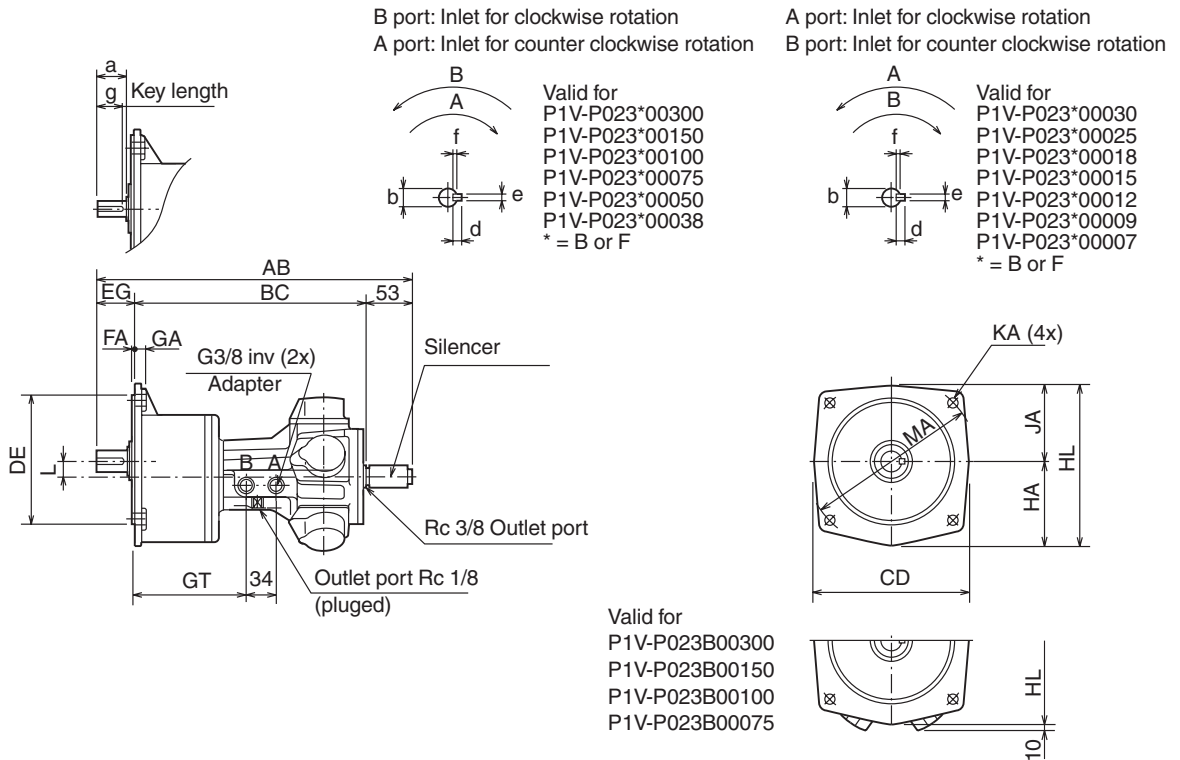

Reversible motor with gearbox and foot

- P1V-P023F00300
- P1V-P023F00150
- P1V-P023F00100
- P1V-P023F00075
- P1V-P023F00050
- P1V-P023F00038
- P1V-P023F00030
- P1V-P023F00025
- P1V-P023F00018
- P1V-P023F00015
- P1V-P023F00012
- P1V-P023F00009
- P1V-P023F00007

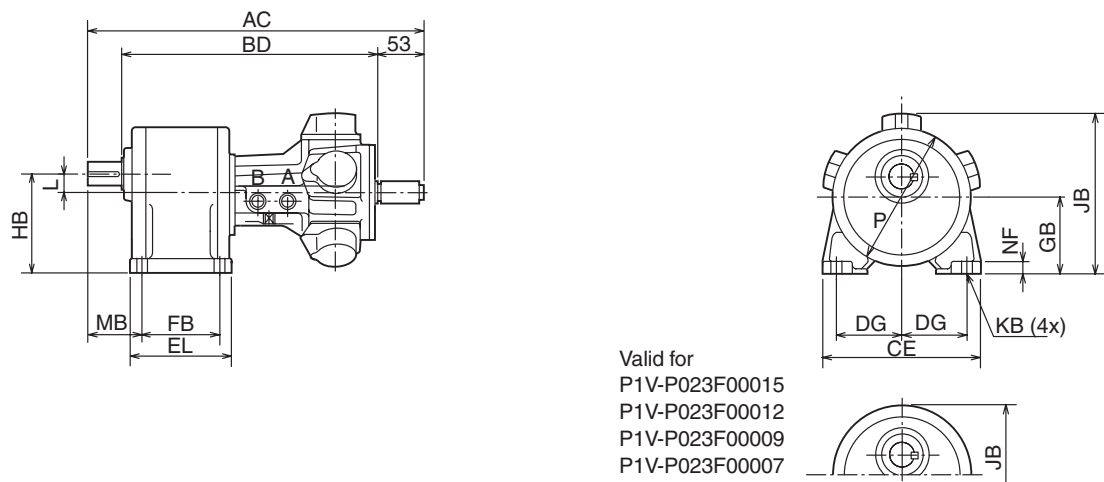

Dimension tables

Motor	AB	AC	BC	BD	CD	CE	DE	DG	EG	EL	FA	FB	GA	GB	GT	HA	HB	HL
P1V-P023*00300 P1V-P023*00150																		
P1V-P023*00100 P1V-P023*00075	374	-	271	276	186	175	Ø170h7	70	50	125	4	90	15	86,5	133	105,5	110	198,5
P1V-P023*00050 P1V-P023*00038																		
P1V-P023*00030 P1V-P023*00025																		
P1V-P023*00018	403	-	290	295	215	208	Ø180h7	85	60	168	4	130	15	101,5	152	126,5	130	234,0
P1V-P023*00015 P1V-P023*00012																		
P1V-P023*00009 P1V-P023*00007	431	428	307	310	270	254	Ø230h7	105	71	196	5	150	18	116,0	170	149,0	150	284,0

Motor	JA	JB	KA	KB	L	MA	MB	NF	P	Shaft end								
										a	b	d	e	f	g			
P1V-P023*00300 P1V-P023*00150																		
P1V-P023*00100 P1V-P023*00075	93,0	180,0	Ø11	Ø11	23,5	Ø215	65	15	Ø152	45	Ø28h6	7	8	4	40			
P1V-P023*00050 P1V-P023*00038																		
P1V-P023*00030 P1V-P023*00025																		
P1V-P023*00018	107,5	198,0	Ø13	Ø13	28,5	Ø250	70	18	Ø184	55	Ø32h6	8	10	5	50			
P1V-P023*00015 P1V-P023*00012																		
P1V-P023*00009 P1V-P023*00007	135,0	230,0	Ø18	Ø15	23,5	Ø310	90	20	Ø218	65	Ø40h6	8	12	5	60			

Reversible motor with gearbox, brake and flange

- P1V-P012BB0360
- P1V-P012BB0180
- P1V-P012BB0120
- P1V-P012BB0090
- P1V-P012BB0060
- P1V-P012BB0050
- P1V-P012BB0040
- P1V-P012BB0030
- P1V-P012BB0022
- P1V-P012BB0018
- P1V-P012BB0015
- P1V-P012BB0012
- P1V-P012BB0009

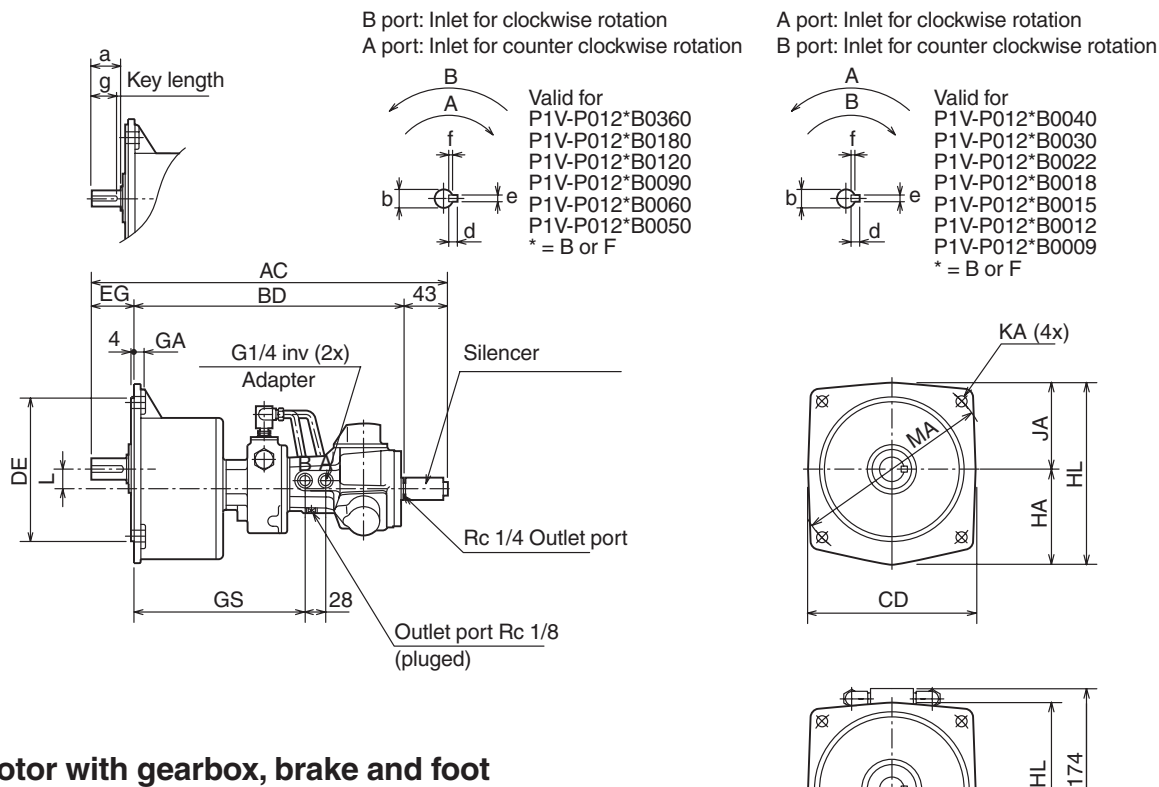

Reversible motor with gearbox, brake and foot

- P1V-P012FB0360
- P1V-P012FB0180
- P1V-P012FB0120
- P1V-P012FB0090
- P1V-P012FB0060
- P1V-P012FB0050
- P1V-P012FB0040
- P1V-P012FB0030
- P1V-P012FB0022
- P1V-P012FB0018
- P1V-P012FB0015
- P1V-P012FB0012
- P1V-P012FB0009

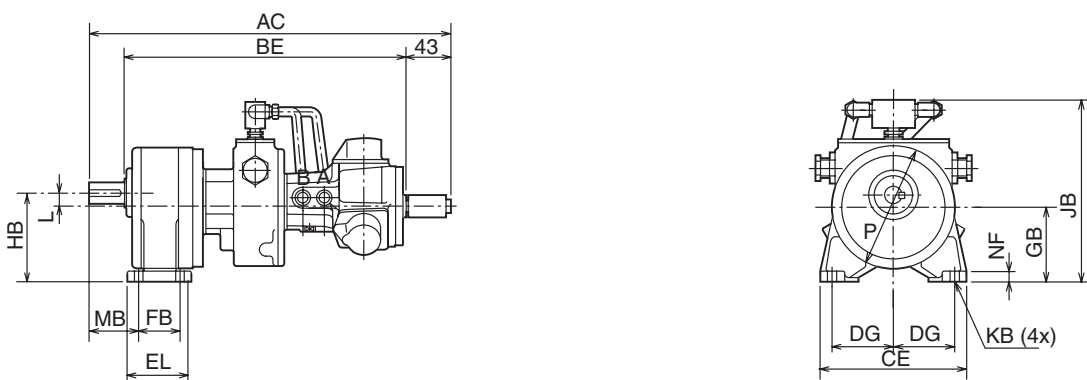

Dimension tables

Motor	AC	BD	BE	CD	CE	DE	DG	EG	EL	FB	GA	GB	GS	HA	HB	HL
P1V-P012*B0360 P1V-P012*B0180																
P1V-P012*B0120 P1V-P012*B0090	401	311	318	164	154	Ø148h7	65	47	90	65	12	71,0	193	89,0	90	174,0
P1V-P012*B0060 P1V-P012*B0050																
P1V-P012*B0040 P1V-P012*B0030																
P1V-P012*B0022	417	324	329	186	175	Ø170h7	70	50	125	90	15	86,5	206	105,5	110	198,5
P1V-P012*B0018 P1V-P012*B0015																
P1V-P012*B0012 P1V-P012*B0009	438	335	340	215	208	Ø180h7	85	60	168	130	15	101,5	217	126,5	130	234,0

Motor	Shaft end														
	JA	JB	KA	KB	L	MA	MB	NF	P	a	b	d	e	f	g
P1V-P012*B0360 P1V-P012*B0180															
P1V-P012*B0120 P1V-P012*B0090	82,5	175	Ø11	Ø11	19,0	Ø185	55	12	Ø125	40	Ø22H6	45	Ø28h6	7	8
P1V-P012*B0060 P1V-P012*B0050															
P1V-P012*B0040 P1V-P012*B0030															
P1V-P012*B0022	93,0	191	Ø11	Ø11	23,5	Ø215	65	15	Ø152	45	Ø28H6	55	Ø32h6	8	10
P1V-P012*B0018 P1V-P012*B0015															
P1V-P012*B0012 P1V-P012*B0009	107,5	206	Ø13	Ø13	28,5	Ø250	70	18	Ø184	55	Ø32H6	65	Ø40h6	8	12

Reversible motor with gearbox, brake and flange

- P1V-P023BB0300
- P1V-P023BB0150
- P1V-P023BB0100
- P1V-P023BB0075
- P1V-P023BB0050
- P1V-P023BB0038
- P1V-P023BB0030
- P1V-P023BB0025
- P1V-P023BB0018
- P1V-P023BB0015
- P1V-P023BB0012
- P1V-P023BB0009
- P1V-P023BB0007

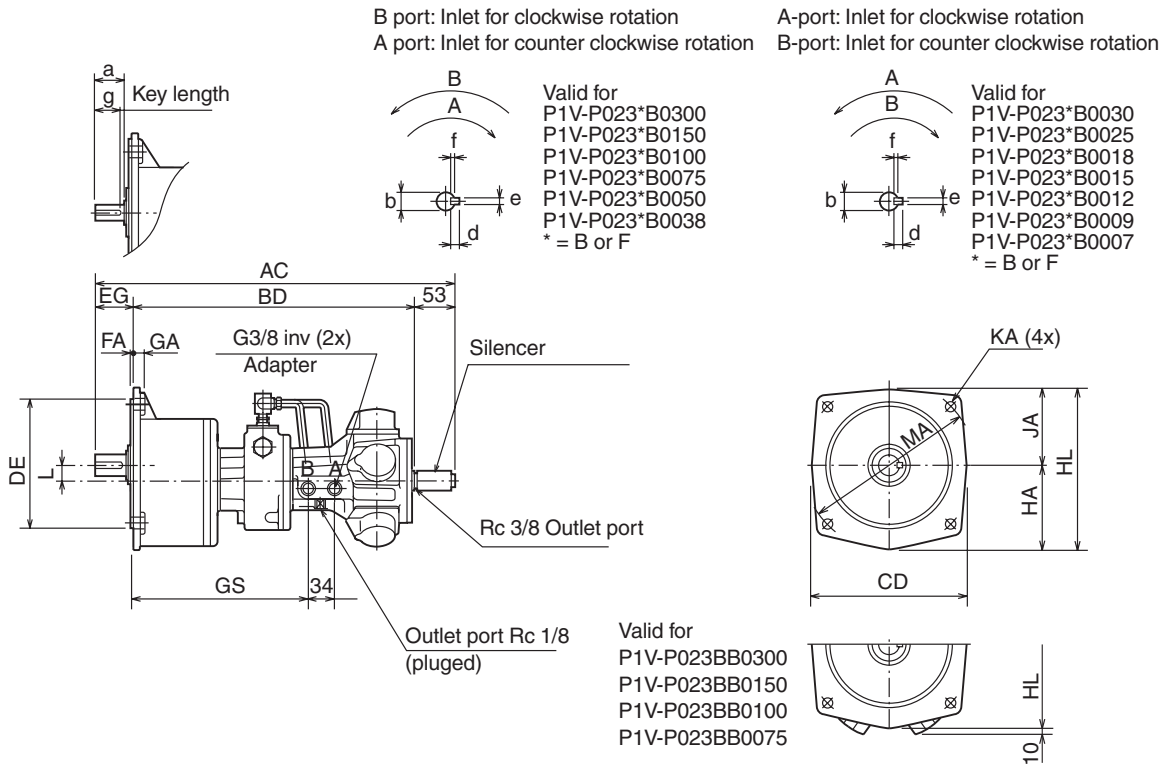

Reversible motor with gearbox, brake and foot

- P1V-P023FB0300
- P1V-P023FB0150
- P1V-P023FB0100
- P1V-P023FB0075
- P1V-P023FB0050
- P1V-P023FB0038
- P1V-P023FB0030
- P1V-P023FB0025
- P1V-P023FB0018
- P1V-P023FB0015
- P1V-P023FB0012
- P1V-P023FB0009
- P1V-P023FB0007

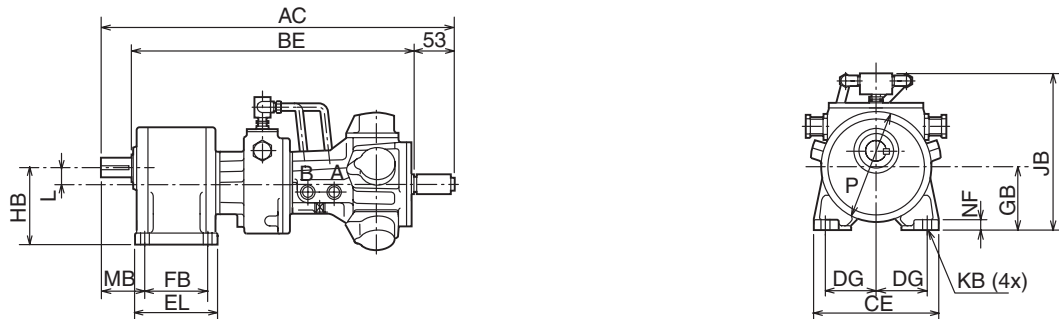

Dimension tables

Motor	AC	BD	BE	CD	CE	DE	DG	EG	EL	FA	FB	GA	GB	GS	HA	HB	HL
P1V-P023*B0300 P1V-P023*B0150																	
P1V-P023*B0100 P1V-P023*B0075	466	363	368	186	175	Ø170h7	70	50	125	4	90	15	86,5	225	105,5	110	198,5
P1V-P023*B0050 P1V-P023*B0038																	
P1V-P023*B0030 P1V-P023*B0025																	
P1V-P023*B0018	495	382	387	215	208	Ø180h7	85	60	168	4	130	15	101,5	244	126,5	130	234,0
P1V-P023*B0015 P1V-P023*B0012																	
P1V-P023*B0009 P1V-P023*B0007	520	396	402	270	254	Ø230h7	105	71	196	5	150	18	116,0	259	149,0	150	284,0

Motor	JA	JB	KA	KB	L	MA	MB	NF	P	Shaft end							
										a	b	d	e	f	g		
P1V-P023*B0300 P1V-P023*B0150																	
P1V-P023*B0100 P1V-P023*B0075	493,0	205	Ø11	Ø11	23,5	Ø215	65	15	Ø152	45	Ø28H6	7	8	4	40		
P1V-P023*B0050 P1V-P023*B0038																	
P1V-P023*B0030 P1V-P023*B0025																	
P1V-P023*B0018	107,5	220	Ø13	Ø13	28,5	Ø250	70	18	Ø184	55	Ø32H6	8	10	5	50		
P1V-P023*B0015 P1V-P023*B0012																	
P1V-P023*B0009 P1V-P023*B0007	135,0	234	Ø18	Ø15	34,0	Ø310	90	20	Ø218	65	Ø40H6	8	12	5	60		

Theoretical calculations

This section provides you with the background you need in order to select the right air motor for common applications.

The first four parts explain the direct physical relationships between:

Force - Torque - Speed - Power Requirement

Before selecting an air motor, you need to know the torque required by the application at the necessary speed. Sometimes, the torque and the speed are not known but the power requirement and the speed of movement are. You can use the following formulas to calculate the speed and torque.

Power

The power requirement is always calculated in N.

Formula:

$$F = m \times g$$

F = power in N
 m = mass in kg
 g = gravitation (9,81) in m/s²

In this example, the mass is 150 kg

$$F = 150 \times 9,81 \text{ N}$$

$$F = 1470 \text{ N}$$

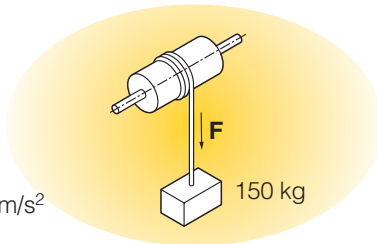

Torque

Torque is the force applied to produce rotational motion (rotational force) or the force applied in the opposite direction. It is the product of the rotational force F and the distance from the pivot point (radius or moment arm)

Formula:

$$M = m \times g \times r$$

M = torque in Nm
 m = mass in kg
 g = gravitation (9,81) in m/s²
 r = radius or moment arm in m

In this example, the drum diameter is 300 mm, which means the radius r = 0,15 m, and the mass is 150kg.

$$M = 150 \times 9,81 \times 0,15 \text{ Nm}$$

$$M = 221 \text{ Nm}$$

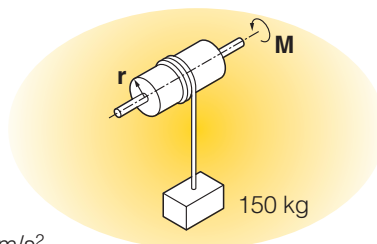

Speed

The required motor speed can be calculated if the speed of movement and the radius (diameter) are known.

$$n = v \times 60 / (2 \times \pi \times r)$$

n = motor speed in rpm
 v = speed of movement in m/sec
 r = radius in m
 π = constant (3,14)

In this example, the speed of movement is 1,5 m/s and the drum diameter is 300 m (radius r = 0,15 m)

$$n = 1,5 \times 60 / (2 \times \pi \times 0,15) \text{ rpm}$$

$$n = 96 \text{ rpm}$$

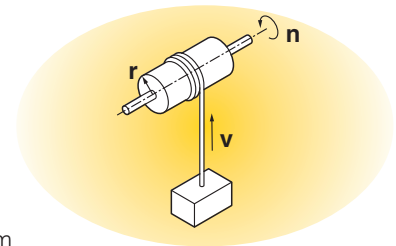

Power Requirement

The power requirement can be calculated if the motor speed and torque are known.

$$P = M \times n / 9550$$

P = power in kW
 M = torque in Nm
 n = rpm
 9550 = conversion factor

In this example, a torque of 1,25 Nm is required at a speed of 1500 rpm.

$$P = 1,25 \times 1500 / 9550$$

$$P = 0,196 \text{ kW or approx. 200 Watt}$$

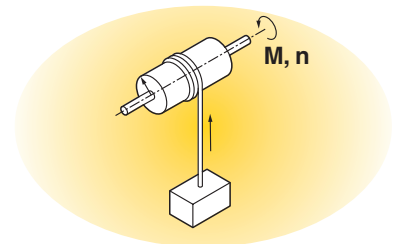

Frictional Forces between two Objects

A frictional force always occurs between two objects with surfaces in contact with each other. It is always exerted against the direction of movement.

The frictional force is either static or kinetic. When selecting an air motor, we need to consider the larger of the two forces, static or kinetic.

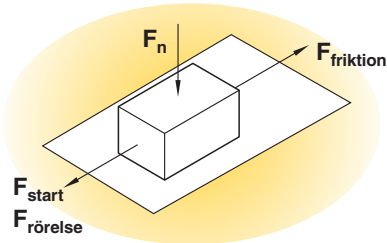

The size of the static frictional force or the kinetic frictional force is the product of the normal force F_n and the coefficient of static friction (μ_0), or the product of the normal force F_n and the coefficient of kinetic friction (μ).

The size of the contact surface between the objects is irrelevant.

Formula:

$$F_{\text{static}} = F_n \times \mu_0$$

$$F_{\text{kinetic}} = F_n \times \mu$$

$$F_n = m \times g$$

- F_{static} = static friction in N
- F_{kinetic} = kinetic friction in N
- F_n = force from object in N
- m = mass in kg
- g = gravitation (9,81) in m/s²

Material		Coefficient of static friction μ_0	
		Dry	Lubricated
Bronze	Bronze	0,28	0,11
Bronze	Grey iron	0,28	0,16
Grey iron	Grey iron	-	0,16
Steel	Bronze	0,27	0,11
Steel	Ice	0,027	-
Steel	Grey iron	0,20	0,10
Steel	Steel	0,15	0,10
Steel	White metal	-	-
Wood	Ice	-	-
Wood	Wood	0,65	0,16
Leather	Grey iron	0,55	0,22
Brake lining	Steel	-	-
Steel	Nylon (polyamide)	-	-

Material		Coefficient of kinetic friction μ	
		Dry	Lubricated
Bronze	Bronze	0,2	0,06
Bronze	Grey iron	0,21	0,08
Grey iron	Grey iron	-	0,12
Steel	Bronze	0,18	0,07
Steel	Ice	0,014	-
Steel	Grey iron	0,16	0,05
Steel	Steel	0,10	0,05
Steel	White metal	0,20	0,04
Wood	Ice	0,035	-
Wood	Wood	0,35	0,05
Leather	Grey iron	0,28	0,12
Brake lining	Steel	0,55	0,40
Steel	Nylon (polyamide)	0,5	0,10

Example: A steel component with a weight of 500 kg is to be pulled across bronze plate without lubrication. What will the frictional force be when the component moves?

$$F_{\text{static}} = F_n \times \mu_0$$

$$F_{\text{kinetic}} = F_n \times \mu$$

$$F_{\text{static}} = 500 \times 9,81 \times 0,27 = 1324 \text{ N}$$

$$F_{\text{kinetic}} = 500 \times 9,81 \times 0,18 = 883 \text{ N}$$

The static frictional force should always be compared with the force provided by the motor when it starts.

Kinetic Resistance

Kinetic resistance is a term expressing the total resistance, consisting of rolling resistance and the frictional force in the bearing

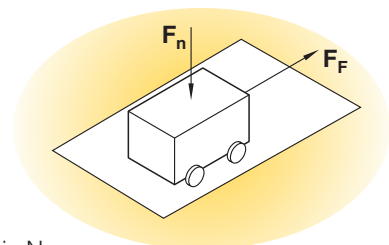

Formula:

$$F_F = \mu_F \times F_n$$

F_F = kinetic resistance in N

μ_F = coefficient of kinetic resistance

F_n = force from object in N

Coefficient of kinetic resistance:

Object	Coefficient of kinetic resistance
Railway vehicle on steel rails	0,0015 to 0,0030
Vehicle with rubber wheel on asphalt	0,015 to 0,03

Example:

A railway carriage with a weight of 2 tonnes is to move over flat rails. What will the kinetic resistance be?

$$F_F = \mu_F \times F_n$$

$$F_F = 0,0030 \times 2 \times 1000 \times 9,81$$

$$F_F = 4,86 \text{ N}$$

Moving a component over a base, with friction between them

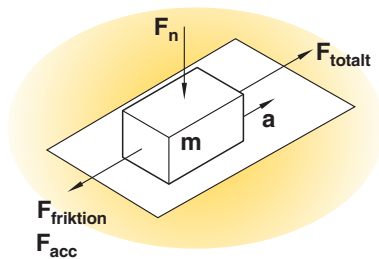

The force required to move the component consists of two parts - a frictional force to move the component over the base, and an acceleration force

$$F_{tot} = F_{friction} + F_{acc}$$

$$F_{acc} = m \times a$$

$$F_{tot} = F_{friction} + m \times a$$

F_{tot} = the total force required in order to move the object in N

$F_{friction}$ = frictional force in N (either F_{static} or $F_{kinetic}$ depending on which is the greater force)

F_{acc} = acceleration force in N

m = mass in kg

a = acceleration in m/s^2

A steel component weighing 500 kg is to be pulled over a dry steel plate with an acceleration of $0,1 m/s^2$. What is the total force required to produce this movement?

$$F_{tot} = F_{kinetic} + F_{acc}$$

$$F_{tot} = F_{kinetic} + m \times a$$

$$F_{tot} = F_n \times u + m \times a$$

$$F_{tot} = 500 \times 9,81 \times 0,15 + 500 \times 0,1$$

$$F_{tot} = 735,75 + 50$$

$$F_{tot} = 785,75 \text{ N}$$

Answer: A force of 780 N is required to produce this movement.

Moving a carriage over rails, with kinetic resistance between them

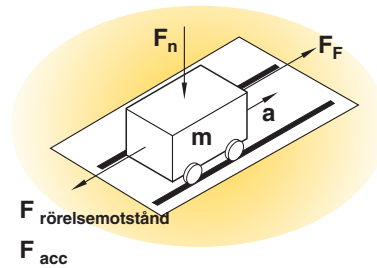

The force required to move the component consists of two parts - a kinetic resistance to move the component over the base, and an acceleration force

$$F_{tot} = F_{kinetic\ resistance} + F_{acc}$$

$$F_{acc} = m \times a$$

$$F_{tot} = F_{kinetic\ resistance} + m \times a$$

F_{tot} = the total force required in order to move the object in N

$F_{kinetic\ resistance}$ = total kinetic resistance in N

F_{acc} = acceleration force in N

m = mass in kg

a = acceleration in m/s^2

A carriage weighing 2500 kg is to be pulled over steel rails with an acceleration of $0,2 m/s^2$. What is the total force required to produce this movement?

$$F_{tot} = F_{kinetic\ resistance} + F_{acc}$$

$$F_{tot} = u_F \times F_n + m \times a$$

$$F_{tot} = 0,0030 \times 2500 \times 9,81 + 2500 \times 0,2$$

$$F_{tot} = 6,1 + 500$$

$$F_{tot} = 506 \text{ N}$$

Answer: A force of 510 N is required to produce this movement.

In practice

These calculations only produce values as they would be under optimum conditions. There must be no inclines in either direction. In applications using carriages, the rails must be perfectly flat without any inclines, the wheels must be perfectly round and there must be nothing on the rails (grains of sand, etc.). There must also be no effects from wind, etc.

In addition, there is always uncertainty with regard to the compressed air supply. How can we guarantee a pressure of 6 bar to the inlet port of the air motor?

Tip: calculate the required theoretical values for the air motor and assume a safety factor of 10 for the frictional force or kinetic resistance, and add this to the acceleration force. If the motor proves to be too powerful in practice, the supply air can always be regulated by throttling or pressure regulation. If you select a motor that is not powerful enough, on the other hand, the only option is to replace it.

Installation instructions

Mounting

P1V-P Air Motors can be built-in in all positions. It is important to get the output spindle in centre to the driven part to avoid unnecessary axial or side load on the motor. Axial couplings are recommended to be used between the motor and the driven part to get the longest possible service life on the P1V-P Motor.

Ventilation port

- Ventilation port is to remove air pressure in the Air Motor. It shall always be kept open. If it is plugged will the internal pressure in the motor increase, resulting in reduction of the output power. Further, a trouble of come-off of the end cover will be caused.
- When delivered the silencer is not mounted on the ventilation port. It has to be assembled before start of the motor.
- When the motor is running can dirty and/or air with oil mist come out of the ventilation port. To avoid it to come out in the air in the surroundings creating environmental problems will it be necessary to take it away to one dirt/oil exhaust filter.

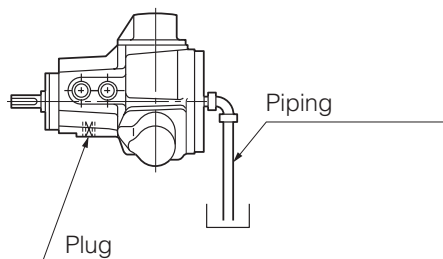
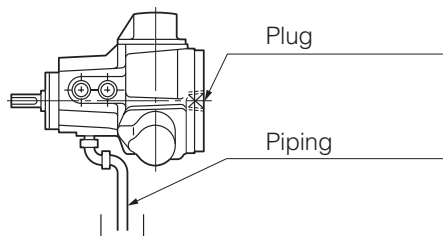
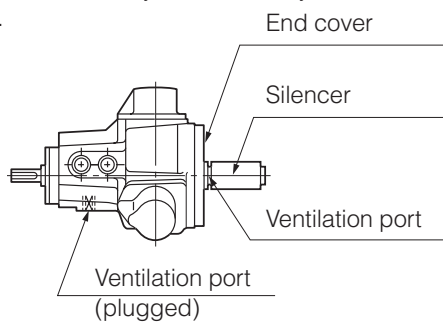

Piping

- The pneumatic equipment (filter, regulator, lubricator, directional control valve, speed control valves....) has to be mounted as close as possible to the P1V-P motor.
- Trouble of pneumatic equipment is mainly caused by foreign matters included dust, chips, scrap of tape seal, rust etc. Before piping, the piping shall be cleaned with compressed.
- For piping bore and pneumatic equipment (filter, regulator, directional control valve etc.) bore corresponding to the air consumption of the air motor has to be used to avoid pressure drop in the inlet port of the motor. When pipe or pneumatic equipment with smaller bore are used will the inlet pressure of the motor be too low and the performance will decrease. Piping with larger bores than the port connection is preferred.
- Clean, dry and lubricated compressed air has to be used (see the chapter "Compressed air quality on page 10)
- Use one as effective silencer as possible on the exhaust air. One silencer/oil absorption filter is preferred.
- All components on the exhaust side has to be enough large to avoid backpressure to the motor. Backpressure will reduce the output performance of the motor.
- Be sure to use one motor with the right speed for the application. The motor has to work with a speed of 20 – 50% of the free speed. A lower speed will not give a stable function and a higher speed will increase the internal wear.

Lubrication

- P1V-P has to be supplied with lubricated compressed air.
- Oil for air tools type VG32 has to be used.
- 2 – 3 drops/minute from the lubricator gives the right amount of oil.

NOTE!

Insufficient lubrication will cause troubles such as shortening of life and seizure of rotary valve, piston and sleeve. Mount an air lubricator as close to the motor as possible.

Permitted shaft loadings

Max. permitted load on output shaft for motors according to tables below.

Basic motors - also with brake

Motor	Radial load [N]	Axial load [N]
P1V-P007**2200	98	59
P1V-P012**1800	137	98
P1V-P023**1500	196	137

**

- A0 = Basic motor
- B0 = Basic motor with flange
- F0 = Basic motor with foot
- AB = Basic motor - with brake
- BB = Basic motor with flange - with brake
- FB = Basic motor with foot - with brake

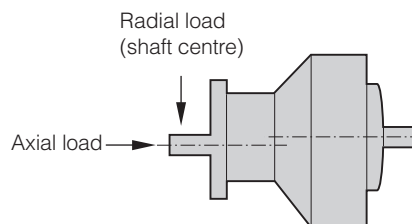

Motor with gearbox and mountings - also with brake

Motor	Radial load [N]	Axial load [N]
P1V-P007**0440	245	147
P1V-P007**0220	539	245
P1V-P007**0147	785	343
P1V-P007**0110	1080	441
P1V-P012**0360	392	245
P1V-P012**0180	785	343
P1V-P012**0120	1080	539
P1V-P012**0090	1370	686
P1V-P012**0060	2160	1130
P1V-P012**0050	2260	1230
P1V-P012**0040	2350	1320
P1V-P012**0030	2450	1370
P1V-P012**0022	1550	1470
P1V-P012**0018	4610	2260
P1V-P012**0015	4710	2550
P1V-P012**0012	5000	2840
P1V-P012**0009	5100	3140
P1V-P023**0300	490	294
P1V-P023**0150	981	441
P1V-P023**0100	1370	637
P1V-P023**0075	1770	834
P1V-P023**0050	3970	1420
P1V-P023**0038	4170	1570
P1V-P023**0030	4320	1670
P1V-P023**0025	4410	1810
P1V-P023**0018	4510	1960
P1V-P023**0015	6470	2550
P1V-P023**0012	6620	2750
P1V-P023**0009	6910	2940
P1V-P023**0007	7060	3140

**

För P1V-P007, P1V-P012 and P1V-P023

- B0 = Motor with gearbox and flange
- F0 = Motor with gearbox and foot

För P1V-P012 and P1V-P023

- BB = Motor with gearbox and flange - with brake
- FB = Motor with gearbox and foot - with brake

Notes

Sales Offices

AE – United Arab Emirates,
Abu Dhabi
Tel: +971 2 67 88 587

AR – Argentina, Buenos Aires
Tel: +54 3327 44 4129

AT – Austria, Wiener Neustadt
Tel: +43 (0)2622 23501-0

AT – Austria, Wiener Neustadt
(Eastern Europe)
Tel: +43 (0)2622 23501 970

AU – Australia, Castle Hill
Tel: +61 (0)2-9634 7777

AZ – Azerbaijan, Baku
Tel: +994 50 2233 458

BE – Belgium, Nivelles
Tel: +32 (0)67 280 900

BR – Brazil, Cachoeirinha RS
Tel: +55 51 3470 9144

BY – Belarus, Minsk
Tel: +375 17 209 9399

CA – Canada, Milton, Ontario
Tel: +1 905 693 3000

CH – Switzerland
See Germany

CN – China, Shanghai
Tel: +86 21 5031 2525

CN – China, Beijing
Tel: +86 10 6561 0520

CZ – Czech Republic, Klecany
Tel: +420 284 083 111

DE – Germany, Kaarst
Tel: +49 (0)2131 4016 0

DK – Denmark, Ballerup
Tel: +45 43 56 04 00

ES – Spain, Madrid
Tel: +34 902 33 00 01

FI – Finland, Vantaa
Tel: +358 (0)20 753 2500

FR – France,
Contamine-sur-Arve
Tel: +33 (0)4 50 25 80 25

GR – Greece, Athens
Tel: +30 210 933 6450

HK – Hong Kong
Tel: +852 2428 8008

HU – Hungary, Budapest
Tel: +36 1 220 4155

IE – Ireland, Dublin
Tel: +353 (0)1 466 6370

IN – India, Mumbai
Tel: +91 22 6513 7081-85

IT – Italy, Corsico (MI)
Tel: +39 02 45 19 21

JP – Japan, Fujisawa
Tel: +(81) 4 6635 3050

KR – South Korea, Seoul
Tel: +82 2 559 0400

KZ – Kazakhstan, Almaty
Tel: +7 3272 505 800

LV – Latvia, Riga
Tel: +371 74 52601

MX – Mexico, Apodaca
Tel: +52 81 8156 6000

MY – Malaysia, Subang Jaya
Tel: +60 3 5638 1476

NL – The Netherlands,
Oldenzaal
Tel: +31 (0)541 585 000

NO – Norway, Ski
Tel: +47 64 91 10 00

NZ – New Zealand, Mt Wellington
Tel: +64 9 574 1744

PL – Poland, Warsaw
Tel: +48 (0)22 573 24 00

PT – Portugal, Leca
da Palmeira
Tel: +351 22 999 7360

RO – Romania, Bucharest
Tel: +40 21 252 1382

RU – Russia, Moscow
Tel: +7 495 645-2156

SE – Sweden, Spånga
Tel: +46 (0)8 59 79 50 00

SG – Singapore
Tel: +65 6887 6300

SL – Slovenia, Novo Mesto
Tel: +386 7 337 6650

SK – Slovakia
See Czech Republic

TH – Thailand, Bangkok
Tel: +662 717 8140

TR – Turkey, Merter/Istanbul
Tel: +90 212 482 91 06 or 07

TW – Taiwan, Taipei
Tel: +886 2 2298 8987

UA – Ukraine, Kyiv
Tel +380 44 494 2731

UK – United Kingdom,
Warwick
Tel: +44 (0)1926 317 878

US – USA, Cleveland
Tel: +1 216 896 3000

US – USA, Miami
(Pan American Division)
Tel: +1 305 470 8800

VE – Venezuela, Caracas
Tel: +58 212 238 5422

ZA – South Africa,
Kempton Park
Tel: +27 (0)11 961 0700

