

General Description

Series AVF (Hydraulic) adjustable velocity fuses are designed to provide automatic hydraulic line rupture shut-off, as well as the ability to isolate a problem circuit on parallel circuit applications. Use of the fuses limits oil spillage and potential component damage. The fuses feature an adjustable flow for easy set-up and operation. A set screw in the body is provided to “lock in” the selected flow.

C

Features

- Provides automatic line rupture shut-off.
- Isolates problem circuit on parallel circuit applications.
- Limits oil spillage and potential component damage.
- Adjustable closing flow — simple readjustment.

Specifications

Service Application	Hydraulic
Maximum Operating Pressure	340 Bar (5000 PSI)
Material	Body, Sleeve, Steel Poppet, Roll Pin Spring Stainless Steel O-ring Fluorocarbon Back-up Ring PTFE Finish Zinc Plated
Operating Temperature	-27°C to +177°C (-20°F to +350°F)
Mounting	Any



Construction View

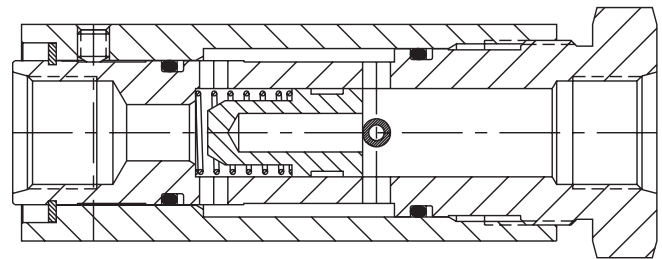

Performance Data

Valve Size	Closing Flow Adjustment Range	
	Minimum	Maximum
1/4"	1.9 LPM (1/2 GPM)	15 LPM (4 GPM)
3/8"	3.8 LPM (1 GPM)	30 LPM (8 GPM)
1/2"	5.7 LPM (1-1/2 GPM)	45 LPM (12 GPM)
3/4"	7.6 LPM (2 GPM)	68 LPM (18 GPM)
1"	11 LPM (3 GPM)	102 LPM (27 GPM)
1-1/2"	23 LPM (6 GPM)	227 LPM (60 GPM)

Pressure drop at maximum rated flow is less than 100 PSID on all sizes.

Ordering Information

Nominal Size	Port Type	
	NPT P/N	SAE P/N
1/4"	AVF-1/4-S28	AVF-106-S28
3/8"	AVF-3/8-S28	AVF-108-S28
1/2"	AVF-1/2-S28	AVF-110-S28
3/4"	AVF-3/4-S28	AVF-112-S28
1"	AVF-1-S28	AVF-116-S28
1-1/2"	AVF-1 1/2-S28	AVF-124-S28

Operation

Series AVF adjustable velocity fuse is a normally open, in-line valve. Under normal conditions, a spring holds the fuse poppet off its seat.

Flow Path

Flow enters the fuse at the flanged inlet port (A). Before reaching the poppet, a series of radial holes (B) in the body directs flow from the body core into an annular cavity (C) between the body and the adjusting sleeve. Flow is directed axially between the body and sleeve until it reaches another series of radial holes (D) at the poppet seat. Flow is then directed back into the body core through the seat and out the fuse outlet port (E).

Making Adjustments

External adjustments of the sleeve reduce the “free” area of the radial holes (D). This reduction in area creates an increase in flow velocity, resulting in a higher pressure drop. When the pressure drop exceeds the spring force holding the poppet open, the inlet pressure will force the poppet against its seat, effectively closing the fuse.

Line Rupture Shut-Off

The sleeve can be adjusted such that, at normal flows, the fuse will remain open but increased flow rates (such as caused by downstream line rupture) will result in a rapid closing of the fuse. The fuse will remain closed until the inlet pressure is eliminated or the downstream pressure is equalized with the inlet.

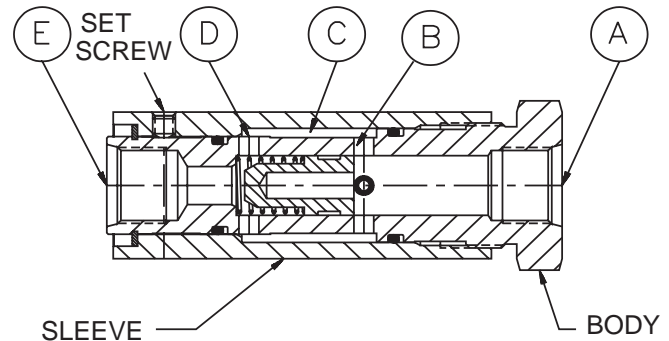

Dimensions

Inch equivalents for millimeter dimensions are shown in (**)

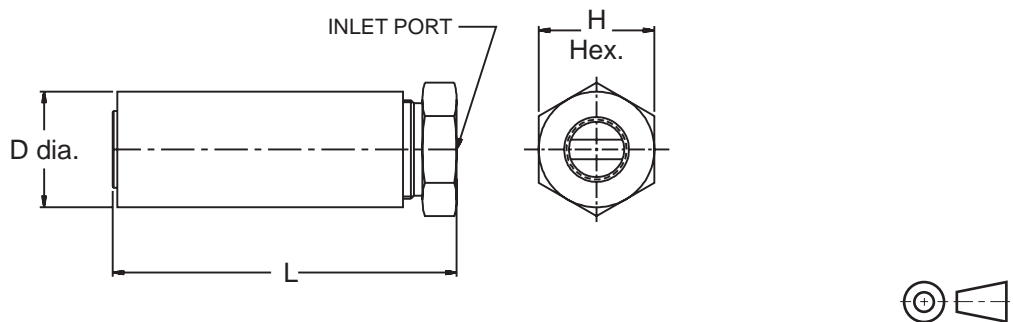

Nominal Size	L mm - (in)	D mm - (in)	H mm - (in)	Weight kg - (lbs.)
1/4"	90 (3.56)	29 (1.13)	29 (1.13)	0.36 (0.8)
3/8"	108 (4.25)	33 (1.31)	33 (1.31)	0.54 (1.2)
1/2"	128 (5.02)	43 (1.69)	43 (1.69)	1.1 (2.4)
3/4"	143 (5.62)	51 (2.0)	51 (2.0)	1.7 (3.8)
1"	168 (6.62)	61 (2.38)	61 (2.38)	2.8 (6.1)
1-1/2"	221 (8.69)	76 (3.0)	76 (3.0)	5.3 (11.6)

Conventional Fuse

- Closing flow must be calculated
- Calculation error results in unusable valve
- System changes make valve unusable
- “Matched” fuses are very expensive
- Special order to meet requirements

AVF Series Adjustable Velocity Fuse

- No calculations required
- Correct size always supplied
- Simple re-adjustment
- Minor adjustment only
- Stocked by pipe size

C

Pump/System Air Bleed

When starting a pump under load, the blocked port resists flow, and more torque is required from the prime mover. This condition may cause an electric motor to draw higher “pull-up current,” or may cause a combustion engine powered pump to stall. The velocity fuse is normally open and when tied into the tank, it will provide an open, load free path to tank when the pump first starts. As the pump nears operating speed, the resulting flow will cause the fuse to close, directing all flow into the primary circuit.

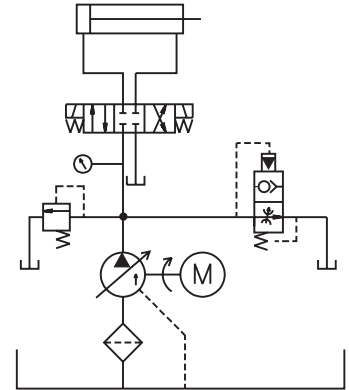

Main Pressure Line from Pump to Manifold

A line rupture in a central power unit would allow fluid to be pumped out through the broken line. The loss of oil can be expensive to clean up, dispose of, and replace; plus it must be done in accordance with EPA regulations. Ruptured lines may cause physical damage or the release of oil into a flammable area. A velocity fuse closes down flow when failure of a line occurs and eliminates these problems.

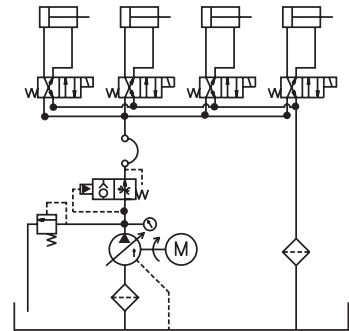

Cylinder/Actuator Shut-Off

A line rupture that occurs when a cylinder is supporting a load allows the load to fall unrestricted. A velocity fuse installed at the cylinder port will shut off flow and prevent the load from falling in the event of a hose or tubing failure.

