

Pilot Operated Regulator

Symbol

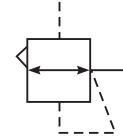

- Integral 3/4" or 1" ports (BSPP & NPT)
- Pilot controlled regulators can be mounted "out of reach" with pilot regulator installed in a convenient location
- Constant pilot bleed control for accurate pressure control
- Balanced poppet provides quick response
- High flow

Options

P3YRA		9	6	BPPN
Basic series	Thread type*	Port size		
Pilot Operated Regulator	BSPP	3/4	6	
P3YRA	NPT	1	8	

* Note: For 1-1/2" ported unit, please order P3YKA*BCP port block kit separately.
Bold items are most common.

Ordering information

Port size	Description	Flow [†] dm ³ /s (scfm)	Max. bar (psig)	Min temp °C (°F)	Max temp °C (°F)	Height mm (inches)	Width mm (inches)	Depth mm (inches)	Weight kg (lb)	Part number [†]
3/4"	Pilot operated regulator	333 (706)	17.5 (254)	-10 (14)	60 (140)	105.5 (4.15)	90 (3.54)	90 (3.54)	1.2 (2.6)	P3YRA96BPPN
1"	Pilot operated regulator	340 (720)	17.5 (254)	-10 (14)	60 (140)	105.5 (4.15)	90 (3.54)	90 (3.54)	1.2 (2.6)	P3YRA98BPPN

† Standard part numbers shown in bold. For other models refer to Options chart above.

‡ Flow with 10 bar (145 psig) inlet pressure, 6.3 bar (91.4 psig) set pressure and 1 bar (14.5 psig) pressure drop.

Specifications

Fluid	Compressed air
Max. pressure air pilot operated	17.5 bar (254 psig)
Operating temperature	-10°C to 60°C (14°F to 140°F)
Weight	3/4" 1.2 kg (2.6 lb)
	1" 1.2 kg (2.6 lb)

Material specifications

Body	Aluminium
Body cover	ABS
Valve	Brass / NBR composite
Pilot valve booster	Aluminum
Seals	Nitrile NBR
Screws	Zinc plated steel

Dimensions mm (inches)

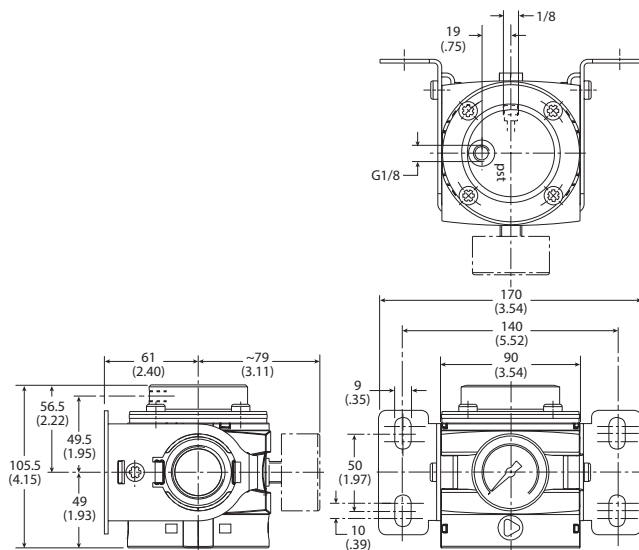

Flow characteristics

