



aerospace
climate control
electromechanical
filtration
fluid & gas handling
hydraulics
pneumatics
process control
sealing & shielding



Condition Monitoring

Products & Custom Solutions



ENGINEERING YOUR SUCCESS.

The Parker Hannifin Filtration Group assures:

- Consistent quality
- Technical innovation
- Premier customer service

Parker's technical resources provide the right filtration technologies that conform to your requirements. That's why thousands of manufacturers and equipment users around the world rely on Parker Filtration products and people.

Worldwide Sales and Service

Parker operates sales and service centers in major industrial areas worldwide. Call 1-800-C-PARKER for more information and for a synopsis of our Filtration Technology Textbook.

Hydraulic, Lubrication & Coolant Filtration

High-performance filtration systems for production machinery in industrial, mobile and military/marine.



Compressed Air & Gas Filtration

Complete line of compressed air/gas filtration products; coalescing, particulate and adsorption filters in many applications in many industries.

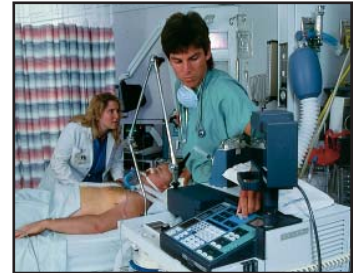

Process & Chemical Fluid Filtration

Liquid filtration systems for beverage, chemical and food processing; cosmetic, paint, water treatment; photo-processing; and micro-chip fabrication.



Fuel Conditioning & Filtration

Parker air, fuel and oil filtration systems provide quality protection for engines operating in any environment, anywhere in the world.



Legal Notifications



FAILURE OR IMPROPER SELECTION OR IMPROPER USE OF THE PRODUCTS AND/OR SYSTEMS DESCRIBED HEREIN OR RELATED ITEMS CAN CAUSE DEATH, PERSONAL INJURY AND PROPERTY DAMAGE.

This document and other information from Parker Hannifin Corporation, its subsidiaries and authorized distributors provide product and/or system options for further investigation by users having technical expertise. It is important that you analyze all aspects of your application and review the information concerning the product or system in the current product catalog. Due to the variety of operating conditions and applications for these products or systems, the user, through its own analysis and testing, is solely responsible for making the final selection of the products and systems and assuring that all performance, safety and warning requirements of the application are met.

The products described herein, including without limitation, product features, specifications, designs, availability and pricing, are subject to change by Parker Hannifin Corporation and its subsidiaries at any time without notice.

Offer of Sale

The items described in this document are hereby offered for sale by Parker Hannifin Corporation, its subsidiaries or its authorized distributors. This offer and its acceptance are governed by the provisions stated in the "Offer of Sale".

© Copyright 2011, Parker Hannifin Corporation, All Rights Reserved.

Content

icountLCM20 Contamination Monitor	1
icountACM20 Lab Unit and icountACM20Z	7
Universal Bottle Sampler	13
icountBS2 Bottle Sampler	17
Single Point Sampler	23
System 20 Sensors and Monitors	26
icountPD and icountPDZ	31
icountOS	41
Moisture Sensor Range	52
Oilcheck Monitor	58
Guide to Contamination Standards	61
Offer of Sale	69

Introduction

Parker Hannifin is comprised of eight global groups: Aerospace, Climate & Industrial Controls, Fluid Connectors, Seal, Hydraulics, Filtration, Automation and Instrumentation.

The Filtration Group consists of ten technical sales and service locations: Finite Filter, Hydraulic Filter Division North America, Hydraulic Filter Division Europe (two locations), Process Filter, Racor, Parker Hannifin Brazil and Parker Hannifin Korea.

Customer Support Information

Technical Support You Can Count On

Parker's technical resources assure you of the right filtration technologies, advanced designs, consistent manufacturing and a network of helpful, specialized professionals trained to support your team.

We listen to you; then we design the right filtration solution. Parker holds over 150 patents on innovative filtration products, including filtration membranes, differential pressure indicators, cartridge bypass valves and spin-in elements.

Parker Filtration makes the technological investments needed to assure the highest quality products. Examples are modern clean rooms, sophisticated testing equipment, CAD/CAM engineering, and CNC integrated equipment that is helping us design tomorrow's filtration products today.

Quality Is Top Priority

Parker Filtration has had a total quality management system in place for years, as well as a Director of Corporate Quality for all of Parker. This structure helps us continually meet our customers' expectations for the highest technical standards, reliable supply and responsive service. From the Group President on down, "Quality" at Parker means more than making a product the right way. Quality permeates our whole organization so that every employee thinks about what he or she does and what is expected by our customers.



"Always Available" Customer Service

Parker Filtration distributors provide local stock and technical design help including 24-hour emergency service. They are further supported by our "ever ready" manufacturing teams.



So if you need more technical literature or applications support please call us toll free at 1-800-253-1258 or at our 24 hour corporate help line at **1-800-C-PARKER**.

Parker Hannifin Corporation
Hydraulic Filter Division
16810 Fulton County Road #2
Metamora, OH 43540
Toll Free: (800) 253-1258
Phone: (419) 644-4311
Fax: (419) 644-6205
<http://www.parker.com/hydraulicfilter>

icountLCM20

Fluid Condition Monitoring

Portable Particle Counter



A portable particle counter designed to be used in the field

icountLCM20 is a proven answer to fluid system contamination monitoring. Multi-standard ISO and NAS cleanliness reporting, data entry, data graphing and integral printing are all standard on this world proven contamination monitor.



Product Features

- icountLCM20 is a proven answer to fluid system contamination monitoring.
- 2-minute test procedure.
- Multi-standard ISO, NAS and AS4059 cleanliness reporting.
- Data entry, data graphing and integral printer.
- 6,000 PSI (420 bar) rated maximum pressure.
- Supported by the offline UBS and online SPS accessories.

icountLCM20

Features & Benefits

Test time:	2 minutes
Particle counts:	MTD 4+, 6+, 14+, 21+, 38+ and 70+ microns(c) ACFTD 2+, 5+, 15+, 25+, 50+ and 100+ microns
International codes:	ISO 7-22, NAS 0-12
Data retrieval:	Memory access gives test search facility
Max. working pressure:	6000 psi (420 bar)
Max. flow rate:	106 GPM when used with system 20 Sensors. Higher with single point sampler
Working conditions:	LCM will operate with the system working normally
Computer compatibility:	Interface via RS232 connection @ 9600 baud rate.

- Special 'diagnostics' are incorporated into the icountLCM microprocessor control to ensure effective testing.
- Routine contamination monitoring of oil systems with icountLCM saves time and saves money.
- Contamination monitoring is now possible during application operation - icountLCM saves on production downtime.

- Data entry allows individual equipment test log details to be recorded.
- Data retrieval of test results from memory via hand set display.
- Automatic test cycle logging of up to 300 tests can be selected via hand set display.
- Totally portable, can be used as easily in the field as in the laboratory.
- Automatic calibration reminder.
- Instant, accurate results achieved with a 2 minute test cycle.
- Data entry allows individual equipment footprint record.
- Data graphing selectable via the integral printer.
- Auto 300-test cycle logging via LCD handset input.
- RS232 to USB computer interface.
- Limit level output to control peripheral equipment such as off-line filtration via internal relay limit switches.
- Auto-testing allows for the conducting of automatic sequencing tests on flushing systems for example.
- Optional bar code swipe wand to allow handset data loading.
- Worldwide service and technical support.
- Re-calibration - Annual certification by an approved Parker Service Center.

Typical Applications

- Construction machinery
- Industrial plant
- Hydraulic equipment & system manufacturers
- Research & testing institutes
- Offshore & power generation
- Marine
- Military equipment applications



icountLCM20

Specifications

Automatic Particle Counters (APC), have been widely used for many years in condition monitoring of hydraulic fluids. However, it is only recently that APCs have become flexible enough to enable the instruments to be taken out of the laboratory and used on-line in order to obtain the most credible form of results.

Unusually, the move from fixed laboratory use, to portable field use has not been at the expense of accuracy or user flexibility, but has actually enabled the instruments to be used over a wider range of applications and situations.

The most common monitoring technique used in APCs is that of light obscuration or light blockage. Here, a focused light source is projected through a moving column of oil, (in which the contaminants being measured are contained), causing an image of the contaminant to be projected on to a photo diode cell, (changing light intensity to an electrical output).

The electrical output of the photo diode cell will vary in accordance with the size of the particles contained in the column of oil; the larger the particle, the bigger the change in the photo diode electrical output.

On-line APCs must be able to test the oil sample at whatever cleanliness it is delivered to the machine. Parker therefore had to develop technology to ensure the on-line APC was able to test a sample without the conventional laboratory technique which requires dilution - a practice that would have been simply impossible with a portable unit.

By careful design and window sizing, 40,000 particles per ml can be achieved without making the instrument susceptible to counter saturation.



A focused light source is projected through a moving column of oil.

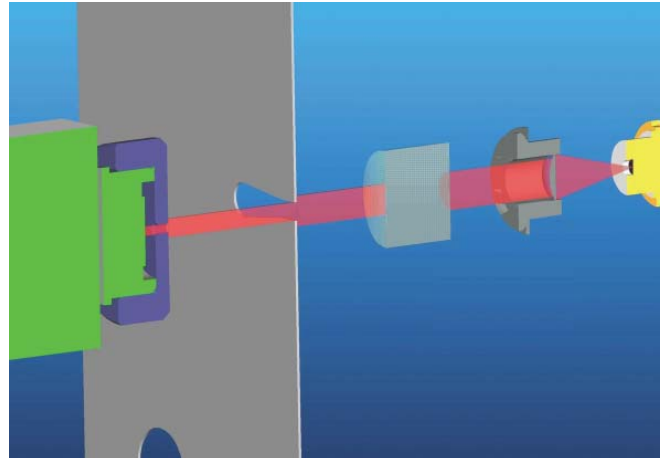

Laser Optical Sensing

icountLCM Proven Core technology

The icountLCM portable particle counter features microprocessor controlled optical scanning for accurate contaminant measurement with a calibration range from ISO 7 to ISO 22 with no counter saturation.

How does icountLCM work?

- The particles are measured by a photo diode that converts light intensity to a voltage output which is recorded against time.
- As the particle moves across the window the amount of light lost is proportional to the size of the particle. This reduction in voltage is measured and recorded.
- This "voltage" lost relates directly to the area of the particle measured, is changed into a "positive" voltage and then in turn changed into a capacitance value.
- This value is counted and stored in the icountLCM computer in one of 6 channels according to particle size.
- Readouts are displayed on the hand-held LCD in the accepted ISO and NAS standards ready for hard copy printing or RS232 computer download.
- The on-board computer allows storage of up to 300 test results.

icountLCM20

Portable Particle Counter

Specification

Description	LaserCM (LCM20 20 22)	LaserCM (LCM20 20 62)
ABS structural foam and injection moulded case	●	●
ABS handheld display	●	●
Mechanical composition – Brass, plated steel, stainless steel and aluminium	●	●
Fluorocarbon seals	●	●
Perfluoroelastomer seals	●	●
Nylon hoses (kevlar braided microbore)	●	●
Stainless steel armoured hose ends	●	●
1.2m fluid connection hose	●	●
Rechargeable battery pack	●	●
12Vdc power supply	●	●
Fast blow fuse	●	●
Unique optical scanning system	●	●
Bonded glass optical window enclosed in SS plate	●	●
Micron channels analysis (Six)	●	●
Analysis range ISO 7 to 22 incl. (NAS 0 to 12)	●	●
32 character dot matrix LCD. Alpha numeric keypad	●	●
Data retrieval	●	●
Calibration to ISO standards*	●	●
Viscosity range 2 to 100 cSt. 500 cSt.with SPS	●	●
Operating temp. 41°F to 176°F (+5°C to +80°C)	●	●
Ambient temp. 41°F to 104°F (+5°C to +40°C)	●	●
2 minute test completion time	●	●
Memory store – 300 test memory	●	●
Battery operated 6 x 1.5 D cells	●	●
Phosphate Ester group compatibility	●	●
Mineral oil & petroleum based fluid compatibility	●	●
Up to 420 bar (6000 psi)	●	●
Integral 16 column printer	●	●
RS232 to USB computer interface	●	●
Astra board case weight – (lb.)	11	11
Unit weight – (lb.)	17.6	17.6
ParSmart software and cable link pack	●	●
Weather protector cover	●	●
CE certified	●	●
Auto logging	●	●

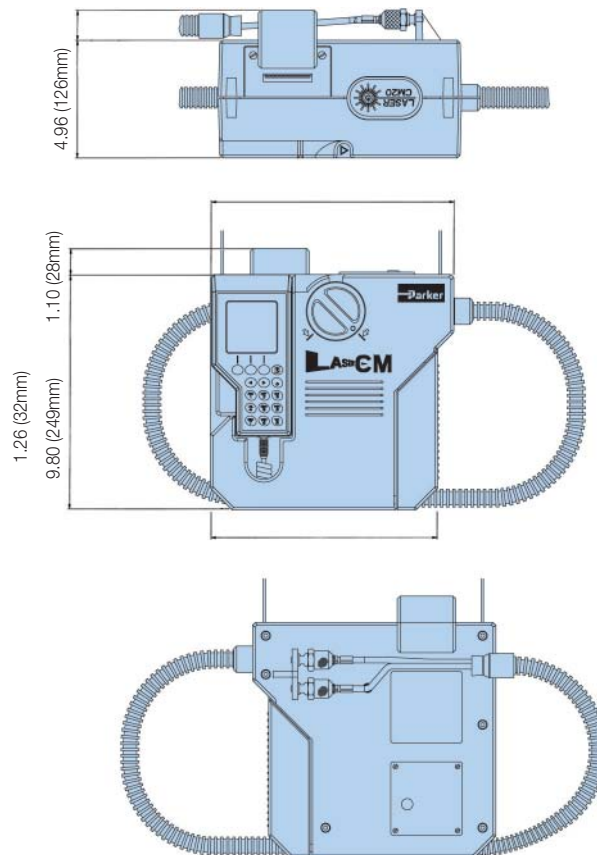

dimensions in inch (mm)

Accessory Kit for icountLCM Classic

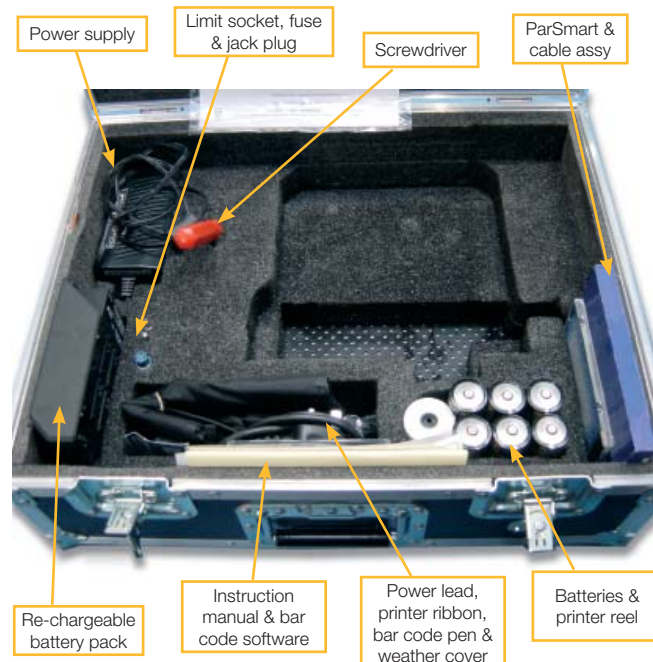

*Note: In compliance with international standards, all Parker portable particle counters can meet the ISO Medium test dust standards. The icountLCM's, in addition to the complete range of Condition Monitoring products, are capable of achieving certification to ISO 4406:1999 and with traceability to ISO 11171 for SRM 2806, via ISO 11943.

icountLCM20

Portable Particle Counter

Why On-Site Fluid Contamination Monitoring?

- Certification of fluid cleanliness levels.
- Early warning instrument to help prevent catastrophic failure in critical systems.
- Immediate results with laboratory accuracy.
- To comply with customer cleanliness requirements and specifications.
- New equipment warranty compliance.
- New oil cleanliness testing.



Data Download Management

Dedicated software, provides the link between an icountLCM20 and your computer management system.



16-column printer for hard copy data. A feature of the icountLCM is the on-board printout data graphing option developed to support predictive maintenance procedures.

icountLCM Test	
ON LINE TEST	
TEST NUMBER 022	
D M Y	
Date	04-03-10
Time	15-52
ISO:	20/15/09
Count / 100ml	
>4µ (c)	820721
>6µ (c)	31564
>14µ (c)	314
>21µ (c)	64
>38µ (c)	14
>70µ (c)	0
NOTES	

icountLCM Test	
ON LINE TEST	
TEST NUMBER 022	
D M Y	
Date	04-03-10
Time	15-52
NAS CLASS:	7
Count / 100ml	
4/6µ (c)	789157
6/14µ (c)	31250
NAS CLASS	7
14/21µ (c)	250
NAS CLASS	3
21/38µ (c)	50
NAS CLASS	3
38/70µ (c)	14
NAS CLASS	4
>70µ (c)	0
NAS CLASS	0
NOTES	

ISO 4406 - 1999

Correlation to NAS 1638

icountLCM20

Portable Particle Counter

Introducing the new icountLCM 'Classic'

There is a new addition to the proven range – the icountLCM 'Classic'. Only available from Parker, the 'Classic' retains all the technology that made the icountLCM one of the most accurate, reliable and popular portable particle counters available.

Our design engineers have re-configured the icountLCM specification in a way that has reduced our manufacturing costs. These savings have been passed onto icountLCM 'Classic' customers.

How have we done this?

Parker listened to our existing customers and then to the engineers and maintenance operatives to find out the features that make the icountLCM a unique predictive maintenance instrument.

Then, we removed peripheral items such as the aluminium case and all the accessories, so a customer receives the icountLCM, with a CD user guide, professionally and securely boxed. One thing that has not altered is the icountLCM accuracy and icountLCM reliability. Our in-house software engineers have re-configured the EPROM, removing Data programming, User ID, Automatic Testing, Data retrieval, Alarm level settings, the barcode pen and Graph printing functions to reduce costs still further without in any way reducing the efficiency of the icountLCM. The icountLCM 'Classic' remains an instrument to be proud of.



Ordering Information (icountLCM and 'Classic' icountLCM)

Model	Fluid Type		Options	
LCM2020	2	Hydraulic mineral	1	icountLCM20 (ACFTD calibrated)
	6	Skydrol	2	icountLCM20 (MTD calibrated)
			3	icountLCM20 'classic' (ACFTD calibrated)
			4	icount LCM20 ' classic' (MTD calibrated)

Note 1: Part numbers featured with bold highlighted codes will ensure a 'standard' product selection.

Note 2: Alternate displayed part number selection will require you to contact Parker Filtration for availability.

Part Number	Supersedes	Description
ACC6NE015	B84702	Printer roll x 5
ACC6NE014	P.843702	Printer ribbon
ACC6NE013	B84609	Re-chargeable battery pack
ACC6ND002	P849603	Weather protector cover
ACC6ND000	B84703	USB to RS232 Download Cable
LCM20.ACCKIT		Accessory Kit for LCM Classic (see p. 4 for content)

Note 1: Part numbers featured with bold highlighted codes will ensure a 'standard' product selection.

Note 2: Alternate displayed part number selection will require you to contact Parker Filtration for availability.

icountACM20 Lab Unit

Aviation Fuel Contamination Monitoring



DEFSTAN 91-91 Issue 6 Jet A-1 Fuel Specification, adopts particle counting.

The first fully functional particle counter approved for use on aviation fuel. After 5 years of development work carried out by Parker UK and partner, the ACM20 has passed all technical barriers and is now approved for aviation fuel quality per DEFSTAN 91-91 Issue 6.

Parker has consistently provided technically superior products to all fluid conditioning applications.



Product Features

- icountACM20 monitors aviation fuel contamination to DEFSTAN 91-91 Issue 6 Jet A-1 fuel specification.
- Energy Institute Test Method IP 564.
- 2-minute test procedure.
- Laser optical scanning analysis.
- Multi-standard ISO cleanliness reporting.
- Case-mounted pump enables monitoring possibilities. For example: Fuel storage/ vehicle tanks and fuel storage drums.
- Latest averaging software as standard.
- ParSmart Downloader software.

icountACM20/icountACM20Z

Features & Benefits

Test Time:
2 minutes

Repeat Test Time:
Every 2 minutes (Manual testing), every 6 minutes (automatic)

Principle of Operation:
Optical scanning analysis and measurement of actual particles and inference to water presence

Primary Output:
 $\geq 4\mu(c)$, $\geq 6\mu(c)$, $\geq 14\mu(c)$, $\geq 21\mu(c)$, $\geq 25\mu(c)$, $\geq 30\mu(c)$ counts per ml

Secondary Diagnostic Output:
% Volume Distribution, via graphical display on handset and printout (printout not available on icountACM20Z)

International codes:
ISO 7-22 in accordance with ISO 4406-1999

Data entry:
32 character two line dot matrix LCD. Full alpha numeric entry facility on keypad

Data retrieval:
Memory access gives test search facility for up to 300 saved tests

Calibration:
In accordance with Parker Calibration Procedure CM20-N, which complies to ISO11171:1999, Clause 6 (Omitting Annex F)

Re-calibration:
Every 12 months by a dedicated Parker Service Centre (Consult Parker) as required under strict EI methods

Max. working pressure:
6,000 PSI (420 bar)

Operating Temperature:
+41°F to +176°F (+5°C to +80°C)

Memory store:
300 test capacity

Computer compatibility:
Interface via RS 232 connection @ 9600 baud rate (USB serial cable to RS232 option available)

Laboratory sampling:
Utilizes on-board rear mounted pump

Portability:
Battery pack and carry case with wheels included

Power requirement:
ACM20: 12vDC input, 6 x 'D' Cell batteries or rechargeable battery pack
ACM20Z: Rechargeable battery pack, or 12vDC input

Printer facility:
Integral 16 column printer for hard copy data (not available on icountACM20Z)

Certification:
Complies with all relevant EC declarations of conformity

icount ACM20 Case Mounted Pump

- Integrated Pump assembly incorporated onto the ACM20 unit.
- Powered directly from ACM20 unit, LED power indication with no additional power supplies required.
- Direct sampling from fuel sample bottles or tank via 3 metre inlet suction tube.
- Incorporated double speed flush and test sequence.
- Managed flow rate/correct volume sample as per IP 564 test method.

icountACM20 is fully compliant with the EI (Energy Institute) test method

Applications

The Parker icountACM20 Portable Particle Counter has been developed from existing technology for monitoring contamination in Aviation Turbine and other hydrocarbon fuels, in accordance with the Energy Institute (EI) Method IP 564.

In addition, the ACM can also be used to monitor various fuels from existing sampling points in locations from refineries, pipelines, distribution terminals, airport fuel supply systems all the way through to the point of uplift into aircraft*.

* Hot works permit required for online sampling (ATEX Zone II unit available).

- **Fuel Testing Laboratories – DEFSTAN 91-91 Issue 6**

In order to better understand dispersed contamination in jet fuel, particle counting is now included alongside existing laboratory techniques

- **Bottle Sampling - Energy Institute (EI) - IP 564**

Laboratory determination of the level of dispersed contamination in aviation fuel using an Automatic Particle Counter (APC)

- **Replace Clear & Bright and Gravimetric**

With the introduction of the icount ACM20, all subjectivity surrounding Clear & Bright and Gravimetric methods can be removed

- **Also for use on petroleum based hydraulic applications (Skydrol compatible available)**

Suitable for use with mineral oil and petroleum based fluid as per standard hydraulic particle counter, reporting fluid cleanliness to ISO 4406:1999

icountACM20 Lab Unit

Specifications

Construction:

ABS structural foam and injection moulded case
Hand-held display - ABS
Keypad fluorosilicone rubber

Mechanical Components:

Brass, plated steel, stainless steel and aluminium

Seals:

Fluorocarbon

Hoses:

Nylon (Kevlar braided microbore). St. steel armoured ends

Flow Rate:

25 - 28ml/min (dictated by CMP) 100ml/min with additional flush button

Fluid Compatibility:

Hydrocarbon Fuel, Mineral Oil. For other fluids consult Parker

Fuse:

1.25 amp fast blow fuse included for overload protection (spare supplied)

icountACM20 Technology:

Patented flow cell, light obscuration

Repeatability/Accuracy:

As per or better than ISO 11171

Coincidence:

40,000 particles per ml

Viscosity Range:

1 -100 centistokes

icountACM20 Weight:

17.6 lbs.

Monitor Carrying Case:

Astra Board case

Carrying Case Weight:

11 lbs.

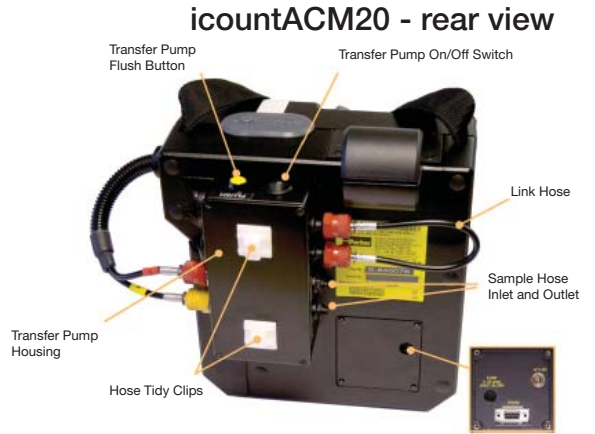

Input Power Socket (note that you will have to remove the plastic dust cap to access the 12Vdc power socket).
A fast blow 1.25A fuse and the RS232 connection are located behind the removable cover plate. The RS232 interface is provided to download all test data stored in the instrument. See the ParSmart Downloader software for more information.

Ordering Information

Standard products table - icount ACM20

Product Number	Supersedes	Description	icountACM20	icountACM20Z
ACM202022UK	N/A	icountACM20 (UK)	X	
ACM202022US	N/A	icountACM20 (US)	X	
ACM202022EUR	N/A	icountACM20 (EURO)	X	
ACM202024UK	N/A	icountACM20 with lab kit - UK (DEFSTAN 9191)	X	
ACM202024US	N/A	icountACM20 with lab kit - US (DEFSTAN 9191)	X	
ACM202024EUR	N/A	icountACM20 with lab kit - EURO (DEFSTAN 9191)	X	
ACM202032UK	N/A	icountACM20 Z2 + online kit & UK battery charger		X
ACM202032US	N/A	icountACM20 Z2 + online kit & US battery charger		X
ACM202032EUR	N/A	icountACM20 Z2 + online kit & Euro battery charger		X
ACM202034UK		icountACM20 Z2 + online & lab kit + UK battery charger		X
ACM202034US		icountACM20 Z2 + online & lab kit + US battery charger		X
ACM202034EUR		icountACM20 Z2 + online & lab kit + Euro battery charger		X
ACC6ND000	B84794	1 meter process cable	X	
ACC6NE006	B84816	ParSMART downloader software	X	
ACC6NE019	P843855	icountACM20 transit Case	X	
ACC6NW003	B84746	Vapour/waste bottle assembly	X	X
ACC6NE029	B84745	Throttle kit	X	
ACC6NE001	B84645	Millipore adaptor kit	X	X
ACC6NE013	B84609	Re-chargeable battery pack	X	
ACC6NE008	B84817	UK power supply	X	X
ACC6NE010	B84830	US power supply	X	
ACC6NE009	B84831	Euro power supply	X	X
ACC6NE020	B84832	UK Offline kit	X	
ACC6NE021		Euro Offline kit	X	
ACC6NE022		US Offline kit	X	
SERMISC067	N/A	500ml verification fluid	X	
ACC6NE015	B84702	Printer reel (x5)	X	
ACC6NE014	P843702	Printer ribbon (x1)	X	
ACC6NE023	B84647	UK battery charger		X
ACC6NE025	B84652	US battery charger		X
ACC6NE024	B84653	Euro battery charger		X
ACC6NE027	B84650	2m process cable assembly		X
ACC6NE028	P843066	Carry case		X

icountACM20Z

ATEX Approved Portable Particle Counter



For use in explosive and hazardous areas

icountACM20Z is designed to be used to monitor various fuels from existing sampling points in hazardous locations such as refineries, pipelines, distribution terminals, airport fuel supply systems all the way through to the point of uplift into aircraft.



Product Features:

- Assembled in an approved and certified stainless steel enclosure to comply with ATEX Directive 94/9/EC.
- Can be used in explosive and hazardous areas, including offshore and mining applications.
- ATEX Zone II
- Certified to CE Ex II 3 G Ex nR/nL IIC T6
- “A” Class product defined for the Aviation market.
- ATEX approved Handset and keypad.
- Suitable for use with mineral oil and petroleum based fluid as per ACM20/LCM20 particle counters.

icountACM20Z

Specifications

Construction:

Unit: Stainless Steel

Carrying case: ABS

Hand-held display: ABS

Keypad: polyester membrane

Mechanical components:

Brass, plated steel, stainless steel and aluminium

Seals: Fluorocarbon

Hoses: Nylon (Kevlar braided microbore)

Fluid compatibility:

All fuels. For other fluids consult Parker

Internal rechargeable battery:

Note: ONLY to be charged outside of the hazardous area, with the unit switched off

Fuse:

1.25A fast blow fuse included for overload protection

Return to Parker Hannifin if fuse is blown

icountACM202032 technology:

Unique optical scanning system



Applications in Fuels

- **Oil Refinery**

- To count and verify the levels of dispersed contamination in accordance with specification limits. (Consult Parker).

- **Distribution Terminals/Hubs**

- For use on receipt and outbound supply. Also to provide filtration performance, tank cleanliness and product quality checks.

- **Storage**

- Settling times can be reduced by monitoring with the ACM by ensuring that levels of dispersed contamination are below acceptable levels.

- **Airport Fuel Farm**

- Monitoring of fuels into storage, through the fuel farm, hydrant system and during uplift into wing.

- **Pipeline Commissioning**

- Fast real time monitoring of pipelines following pigging and cleaning processes.

- **Oil and Gas Platforms**

- Used to monitor the filtration performance, system cleanliness and quality of delivered product.



icountACM20Z

ATEX Approved Portable Particle Counter

Installation Details

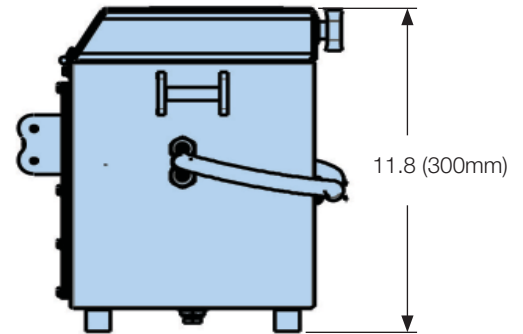
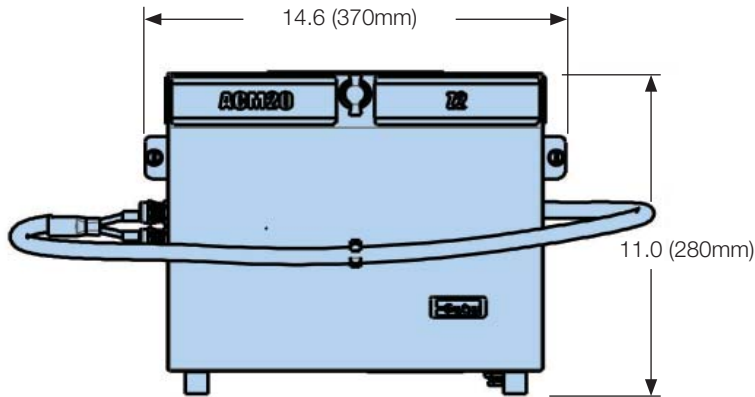

dimensions in inch (mm)

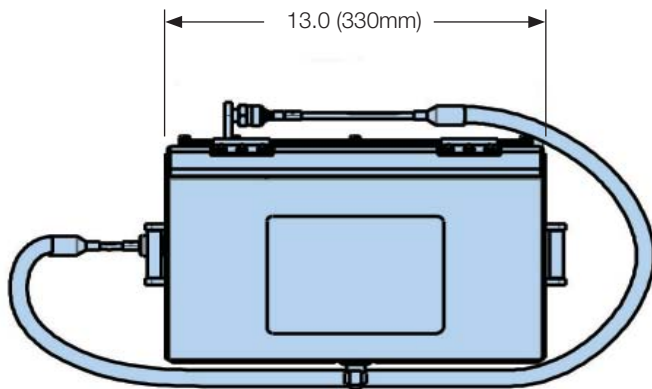

Online Commission Kit

- a – icountACM20 Zone II Particle Counter
- b – Battery Charger
- c – Process Cable
- d – User Manual
- e – Downloader Software
- f – Throttle Kit
- g – Millipore Adaptor Assembly
- h – Aluminium Case
- i – Bottle Assembly



Universal Bottle Sampler

Simple and efficient offline oil sampling



Ideal for batch oil sampling

The UBS provides the dynamic link to portable particle counters. The UBS off-line sampler has microprocessor technology to recognize and adjust to the connecting monitor including the icountLCM20.



Product Features

- Simple operation
- Efficient testing procedure
- Clean and contamination free sampling
- Available for both mineral based and aggressive fluids
- Further advances the LCM20's flexibility into laboratory bottle sampling environments
- Can accept various different sized bottles
- Minimal working parts
- Internal auto setting fuse for overload protection
- Simple maintenance procedures

Universal Bottle Sampler

Specifications

Description	UBS Offline
Viscosity range 2 to 250 cSt	X
Operating temp. 41°F to 176°F (+5°C to +80°C)	X
Test time 2m15s / 4m15s (Flush 2m)	X
12 Vdc power supply	X
Extruded aluminium construction	X
Unit weight - (lb.)	8.82
Mineral oil and petroleum based compatibility	Fluorocarbon seal
Phosphate Ester group compatibility	EPDM seals
CE certified	X
Military approved	X
Manual operation	X
Bottle pack	X
De-gassing chamber	X
Manual	X
Sample tube pack	X
Interface cable to LCM20	X

Installation Details

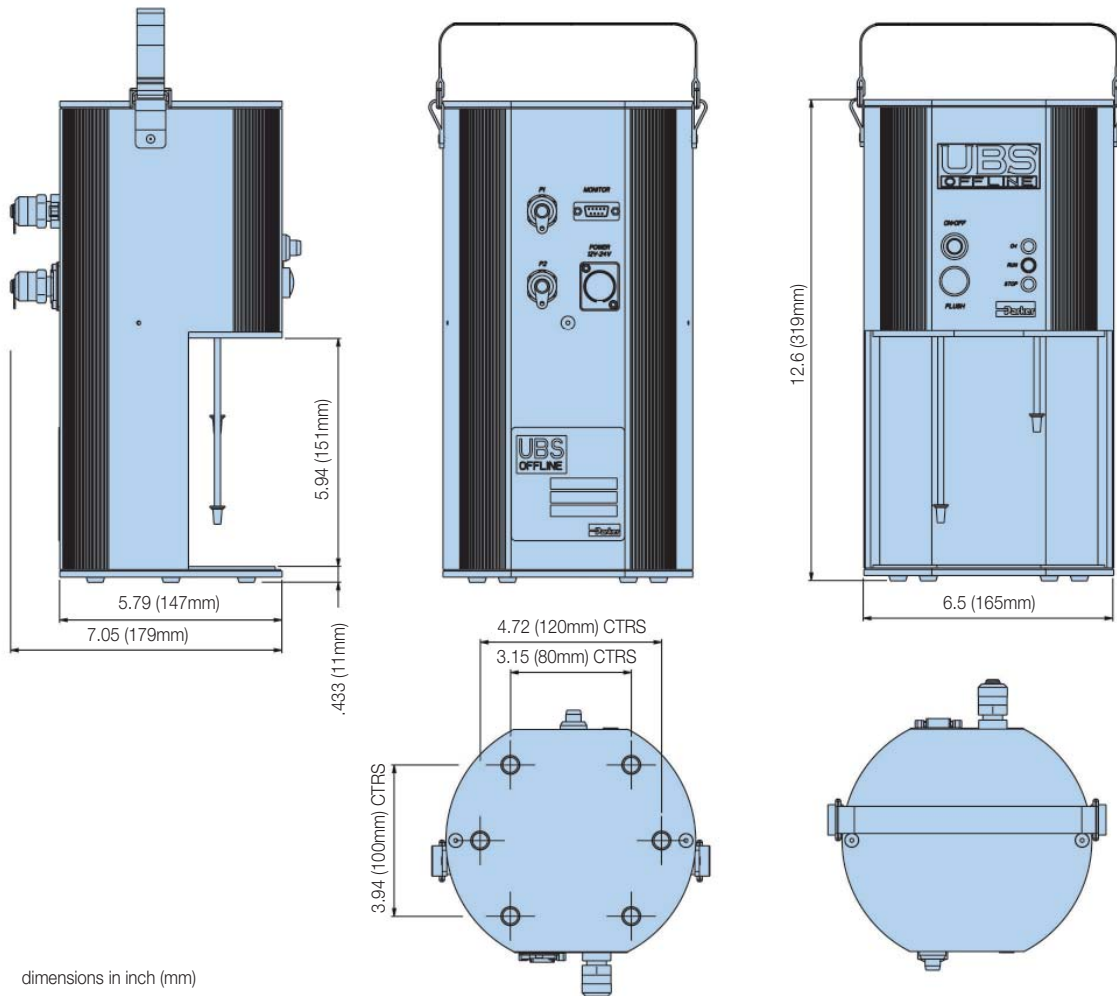

dimensions in inch (mm)

Universal Bottle Sampler

Simple and Efficient Offline Oil Sampling

System Flow Rate

Samples are best taken from a point in the system where the flow is TURBULENT (Reynolds No. greater than 4000). The turbulent flow creates a mixing action. Where flow is streamline or LAMINAR, larger particulate may tend to settle toward the lower pipe surface and not be sampled.

System Condition Changes

Changes in the system operating condition, flow, temperature, pressure or vibration, can result in previously sedimented contaminant being retrained into the flowing oil. It is also possible that these changes may cause partially contaminated filter elements to shed particulate into the system. Samples should, therefore, be extracted when the system is in a steady state condition and the result less likely to be distorted by contaminant peaks.

There are a number of proprietary sampling valves available which adhere to good theoretical principles. However, they do tend to generate a level of precision and cost which is unnecessary for trend monitoring.



Sampling points should enable extraction of a sample without changing the system's condition. Fine control needle valves are not desirable, as they have a tendency to silt up under some operating conditions, causing the distribution of contaminants in the fluid to be changed. The sampling port should be protected to maintain cleanliness and thoroughly flushed before collecting the sample for analysis. Allow sufficient airspace in the bottle to enable 80% fill.

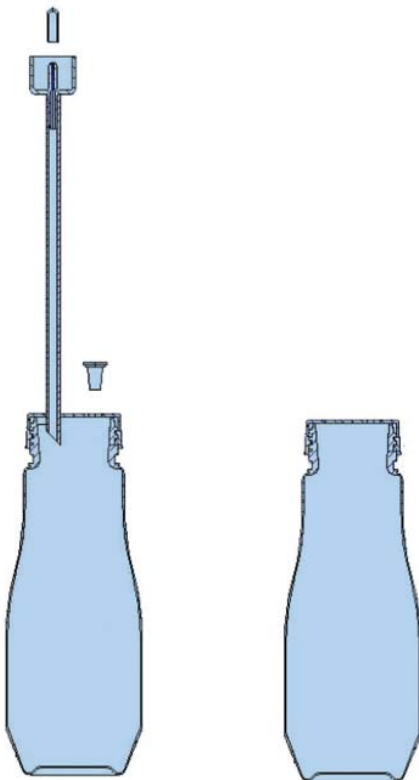

ACC6NW001 x 50 = ACC6NW002

ACC6NK001

Bottle Cleanliness

It is preferable that bottles have sealing screw caps and both parts are cleaned to a suitable level in accordance with ISO3722.

Standard Parker bottles are supplied clean to ISO15/13/10 (NAS Class 4).

The bottle should remain capped until time of sample filling and re-capped immediately afterwards.

Sample Mixing

Sedimentation of contaminant in a sample will occur, the rate of which is dependent upon both fluid and particle characteristics.

Samples should be analysed, without delay, once agitated and de-gassed.

Universal Bottle Sampler

Ordering Information

Standard products table

Part Number	Description
UBS9002	Universal bottle sampler (includes aluminium case and accessories)
UBS9003	Universal bottle sampler
UBS9004	Universal bottle sampler for phosphate ester fluids
UBS9005	Universal bottle sampler (Includes aluminium case and accessories)

Accessories

Part Number	Supersedes	Description
ACC6NK001	B89907	Sample bottle (2/pack)
ACC6NW001	B89911	Sample bottle with extraction hose (2/pack)
ACC6NW002	B89910	Sample bottle with extraction hose (50/pack)
ACC6NK002	S840054	UBS power supply
ACC6NK003	S890005	UBS degassing chamber and pump
ACC6NK004	B89603	UBS degassing chamber only
ACC6NK005	B89902	Cable and adaptor

Note 1: Part numbers featured with bold highlighted codes will ensure a 'standard' product selection.

Note 2: Alternate displayed part number selection will require you to contact Parker Filtration for availability.

Typical Applications

- Batch sampling
- Aircraft rig certification
- Oil research
- Laboratory testing
- Transfer line monitoring





aerospace
 climate control
 electromechanical
filtration
 fluid & gas handling
 hydraulics
 pneumatics
 process control
 sealing & shielding



icountBS - Bottle Sampler

The benchtop solution to fluid contamination bottle sampling



ENGINEERING YOUR SUCCESS.

The Complete Solution - Industrial Design Combined with State of the Art Technology

The icountBS - Bottle Sampler from Parker, with its innovative industrial design, has been developed for customers looking for state of the art technology, attention to detail and the compactness of a permanent laboratory particle analysis instrument.

Combine this with on-board, laser based, leading edge technology to bring to all industries a truly revolutionary Particle Counter. The innovative icountBS is a product from the next generation of Parker's fluid particle analysis and monitoring solutions.

The IBS features an easy to use interactive touch screen, environmentally controlled pressurized bottle chamber, an internal compressor pump, automated door locking mechanism, sample tube cleaning sleeve that minimizes cross contamination, and an internal printer.

The icountBS benefits from Parkers knowledge and experience of providing fluid analysis equipment to the market for over 15 years.

icountBS - Bottle Sampler Features & Benefits

- Customer programmable number of sample runs/sample bottle averaging and pre-test flush volumes from 10ml min. to 100ml max.
- Input via fluid resistant touch screen display.
- Repeatable and reproducible performance to ISO4406:1999, jAS4059E, and NAS1638 particle count distributions. Other calibration standards are included.
- On-board compressor and 'shop' air capable.
- Design concept allowing for portability. DC and rechargeable battery pack options built in.
- Sample tube self cleaning sleeve minimizing cross contamination.
- 500 test sample memory.
- Data download via USB jump drive or USB to USB included.
- Internal printer.





Home Screen



Sample ID Input

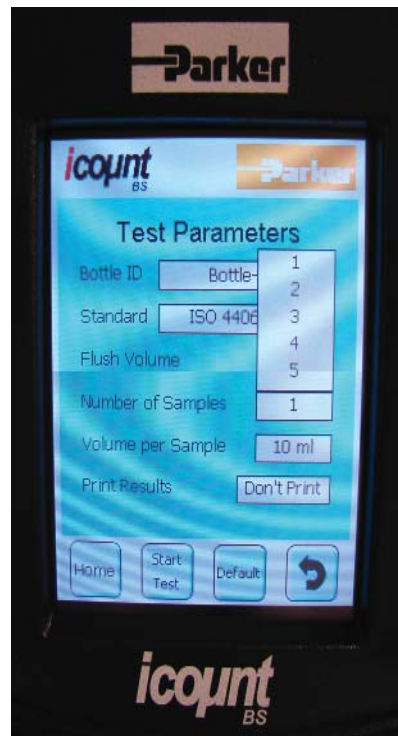

Number of Sample Runs



Sample Volume



Flush Volume



Start Test

Analyzing the Test Results

Once the automatic oil sample test has been completed, what next?

Solid contaminants in fluid power systems vary in size, shape, form and quantity. The most harmful contaminants are normally between 6 microns and 14 microns. The ISO code is the preferred method of reporting quantity of contaminants.

The ISO code number corresponds to contamination

levels relating to three sizes. The first scale number represents the number of particles that are equal to and greater than $4\mu\text{m}$ (c) per ml of fluid, the second number for particles that are equal to and greater than $6\mu\text{m}$ (c) per ml of fluid and the third number for particles that are equal to and greater than $14\mu\text{m}$ (c) per ml of fluid.

For example: An ISO code 20/18/14 indicates that there are between 5,000 - 10,000 particles that are equal to and greater than $4\mu\text{m}$ (c), between

1,300 - 2,500 particles that are equal to and greater than $6\mu\text{m}$ (c), and between 80 - 160 particles that are equal to and greater than $14\mu\text{m}$ (c).



icountBS Product Specification

Principle of Operation	Laser based light obscuration
Dimensions	H=20.9" x W=7.48" (8.27" Door) x D=16.1"
Weight	31 lb. (14kg)
Mechanical Composition	Stainless steel 316, plated mild steel and aluminum
Plastics Composition	Precision polyurethane RIM moldings and ABS plastic
Environmental Operating Temperature (Tested)	41°F to 140°F (+5°C to +60°C)
Operating RH Range	20 - 85% [Tested at 86°F (30°C), no condensation]
Storage Temperature	40°F to 194°F (-40°C to +90°C)
Storage RH Range	10 - 90% (Tested at 30°C, no condensation)
Channel Sizes	MTD - >4μ(c), >6μ(c), >14μ(c), >21μ(c), >38μ(c), >70μ(c), ACFTD - >2μ, >5μ, >15μ, >25μ, >50μ, >100μ
Analysis Range	ISO 7 to 21, NAS 0 to 12
Contamination Standards	MTD - ISO 4406:1999 & NAS 1638 ACFTD - ISO 4406:1987, ISO 4406:1991, NAS 1638, and jAS4059E For further contamination standards consult Parker
Calibration Standard	ISO MTD and ACFTD calibration to traceable ISO Standards. (Contact Parker for further details)
Fluid Management	Maximum single sample = 100ml, Minimum single sample = 10ml
Possible Test Configurations	User selectable from single test up to 5 tests per run (eg. 1 x 100ml up to 5 x 50ml per run)
Pre-Test Flush Volume	Minimum = 10ml, Maximum = 100ml
Viscosity Range	5 to 400 cSt
Fluid Compatibility	Mineral oils, petroleum and hydrocarbon based fluids. For all other fluids, consult factory.
Sample Bottle Size	No specific bottle required. Maximum size = 2.95" (Dia.) x 5.90" (H). Maximum volume = 250ml
Memory Storage	500 tests (capacity warning after 450 tests)
Output Display	Backlight 256 color STN transmissive
Output Display Resolution	320 x 3 (RGB) (H) x 240 (W) dots
Display Active Area	115 (H) x 86 (W) mm
Data Input	Via icon driven resistive touch screen
Printer	Thermal dot-line printing
Printer Paper	Ø50mm - (57mm x 25mm)
Test Certification	Calibration & Certificate of Conformity
Power Supply	DC output - 12V @ 6.60Amps, 80 watts max. AC input - 100 to 240V @ 1.2Amps (50 - 60 Hz)
Battery Power	2 hours (recommended to be fully charged every 3 months)
Battery Stand-By Time	1 month (then 1 hour of operation)
Battery Fuse	6.3 Amps (anti-surge)
Air Pressure Source	50 psi (3.5 bar) internal mini-compressor or 101 psi (7 bar) shop air



icountBS - Bottle Sampler Ordering Information

Part Number
IBS3100US
IBS3000FUS (fuel version)
IBS3000MUS (minilab version)

Accessories	Part Number	Included
250ml Sample Bottle (2/pk)	ACC6NW001	* (2 pks.)
Sample Bottle Pack (50)	ACC6NW002	
Vapour/Waste Bottle	ACC6NW003	*
Waste Bottle Folder	ACC6NW004	
Printer Paper Reel (x1)	ACC6NW005	*
Transport Case	P893865	*
1m Waste Tube (Clear)	ACC6NW009	*
1m Vapour Hose (Blue)	ACC6NW010	*
USB Memory Stick	ACC6NW011	*
icountBS CD Manual	ACC6NW012	*
Air Connector	P.893318	*

* These items included with IBS unit within a transportation case.

Single Point Sampler

Online Sampling



The effective link to ensure accurate contamination monitoring

The SPS (Single Point Sampler) is a lightweight, compact and easy to use online sampling unit that connects an icountLCM20 to a single pressure test point in a fluid system. Suitable for use with mineral and biodegradable oils, petroleum based and phosphate ester fluids, the SPS offers fingertip operated control even at high pressures - 6,000 PSI (420 bar) rated maximum pressure.

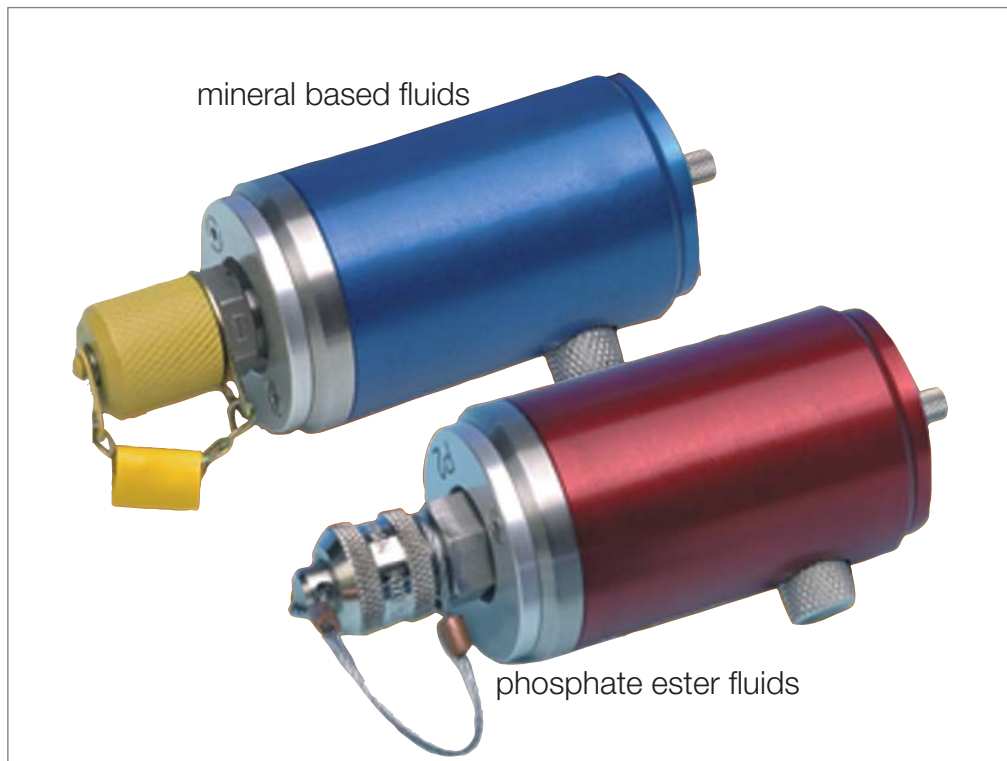

Product Features:

- Lightweight, compact and easy to use online sampling unit.
- Connects an icountLCM20 to a single pressure test point in a fluid system.
- Suitable for use with mineral and biodegradable oils, petroleum based and phosphate ester fluids.
- 6,000 PSI (420 bar) rated maximum pressure

Single Point Sampler

Features & Benefits

The Single Point Sampler provides a means to connect an icountLCM20 to a single pressure test point and balance the differential pressure across the system, to provide a controlled flow of oil into the icountLCM20 and away into a waste oil receptacle.

- Lightweight, compact and easy to use design
- Fingertip operated control valve even at high pressures
- 6,000 PSI (420 bar) rated
- Facilitates testing from large diameter pipework
- Capability to test up to 500cSt viscosity oils (pressure permitting)
- Pressure compensated flow control mechanism
- Possible to control the valve with the same level of accuracy whether the device is operating at high or low pressure
- Capable of allowing a flow rate in excess of 10ml/min when operating at any viscosity within the product specification
- Suitable for fluid temperatures from +5°C to +80°C (+41°F to +176°F)
- High quality polished finish. (stainless steel/ aircraft grade aluminium)
- Capable of working with an icountLCM20 connected into a system via the standard one metre extension hose kit
- Suitable for use with mineral and biodegradable oils, petroleum based and phosphate ester fluids
- Phosphate ester version utilizes the 5/8" BSF HSP style fitting
- Designed so that it meets the lowest possible level of magnetic permeability
- Supplied with accessories kit
- It will maintain the set flow rate between upper and lower limits within a 100 bar inline pressure change
- Clear product identification to ensure that it is connected correctly (i.e. downstream of the icountLCM20).

Connection Instructions

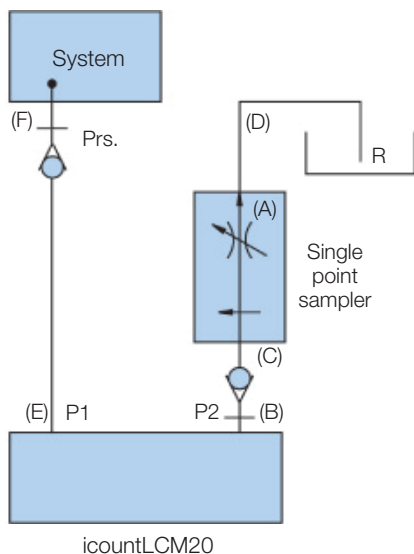

1. Ensure valve is closed (A).
2. Connect P2 on icountLCM20 to P2 on Single Point Sampler (SPS) (C).
3. Connect drain line on SPS (D).
4. Connect P1 of icountLCM20 to the system (F).
5. The SPS is ready to operate.
6. Open valve (A) slowly until the oil flows continuously from the drainline (D) into a reservoir or receptacle (R).
7. Switch on monitor and begin testing.

icountLCM20 Only

Carry out flow test as shown in the manual. If test is showing below Dt 38.5°F (3.6°C) then carry out test as normal. If, however, test is above Dt 38.5°F (3.6°C) then increase oil flow by turning valve (A) anticlockwise and then carry out flow test. Do this until Dt is below 38.5°F (3.6°C) and carry out test as normal once achieved.

WARNING! Ensure that SPS valve is closed and icountLCM20 is connected to the SPS BEFORE connection to system.

Single Point Sampler

Specifications

Fluid Compatibility:

Mineral oil and petroleum based fluids
 Phosphate ester fluid
 For other fluids consult factory

Seals:

Fluorocarbon or Perfluoroelastomer

Maximum Working Pressure:

6,000 PSI (420 bar)

Weight:

500 grams max. (Not including hoses)

Unit Size:

1.77in dia x 4.8in long (45mm dia x 123mm long)

System Connection:

Mineral petroleum fluids - M16 (G1/4" BSP) with cap,
 Phosphate ester - 5/8" BSF HSP

Operating Temperature Range:

+41°F to +176°F (+5°C to +80°C)

Storage Temperature Range:

-15°F to +176°F (-26°C to +80°C)

Construction:

Body: Aluminium BS 1470 – pressurized end stainless steel

Finish: Anodized blue - Mineral fluid

Anodized red - Phosphate ester fluid

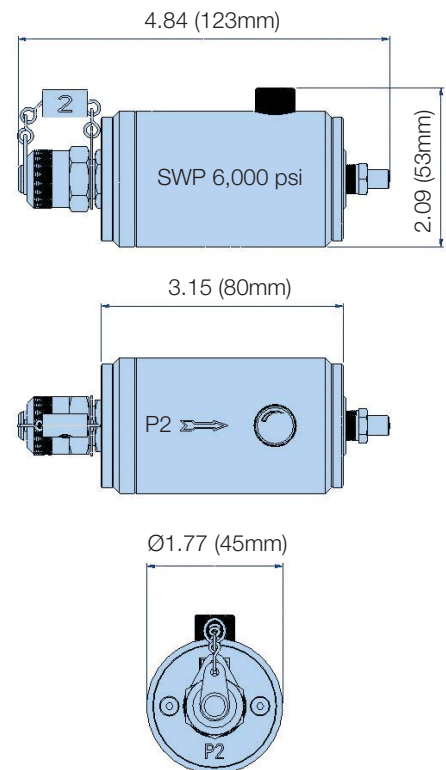

dimensions in inch (mm)

Ordering Information

Standard products table

Part Number	Supersedes	Description
SPS2021	SPS.2021	Single point sampler (mineral fluids)
SPS2061	SPS.2061	Single point sampler (phosphate ester fluids)
ACC6NW003	B84784	Waste bottle (Universal)
ACC6NH001	B84224	Extension hose/coupling (mineral fluids)
ACC6NH002	B84225	Extension hose/coupling (phosphate ester fluids)
ACC6NH003	B84788	Waste hose (mineral fluid)
ACC6NH004	B84787	Waste hose (phosphate ester fluids)

Note 1: Part numbers in bold are 'standard' product selection with all accessories.

System20

Inline Sensors & Monitors



Effective in-line system sensors and monitors

In-line System20 sensors and hand-held monitors designed to give accurate and instant fluid system readings of flow, pressure and temperature. 3 sizes of inline System20 sensor for pressures up to 6,000 PSI (420 bar), an analog monitor that utilizes 3 day-glow gauges with protective cover. EM20 electronic monitor with full digital display and 300 test memory.



Product Features

- 2 types of System20 sensor are available.
STI = industrial with reverse flow capability.
STS = mobile without reverse flow capability.
- 3 sizes of industrial inline System20 sensor for pressures up to 6,000 PSI (420 bar). 2 sizes of Mobile System20 sensor.
- Analog monitor utilizes 3 day-glow gauges with protective cover.
- EM20 electronic monitor with full digital display and 300 test memory.
- For use with all mineral oils, water and oil/water emulsions.

System20

Features & Benefits

Covering a wide range of flow rates, fluid types and applications, Parker's System 20 sensors are designed to be used with System 20 electronic or analog monitors, icountLCM, icountPD and the. Specially developed System20 sensors are available for use with phosphate ester fluids (EPDM Seals).

- System20 monitors, combined with the inline sensor, give the user accurate and instant readings of flow, pressure and temperature without the need for costly system downtime.
- For use with all mineral oils, water and water/oil emulsions.

Analog Monitor (STM)

- Utilizes 3 Day-Glo dial gauges with a protective hinged cover.
- Calibrated up to 100 gpm with dual scale PSI/bar & °F/°C. (USGPM also available)

Electronic Monitor (EM20)

- Gives a full digital display.
- Automatically calibrated for all 3 sizes of sensor.
- Indicates line, differential and rising peak pressure.
- Easily scrolled from metric to US.
- 300 test memory.
- Capable of downloading saved data to download software.

Typical Applications

- Drilling equipment
- Mining
- Grinding and conveying
- Industrial hydraulics
- Mobile applications

Hydraulic system users need to ensure that lost production is kept to the absolute minimum. To ensure this, predictive maintenance utilizing routine condition monitoring of hydraulic systems is essential.



Industrial STI family



2 sizes of System20 Inline Mobile Sensors are available

System20

Specifications: Sensors

Construction:

Industrial: (STI)
 Body: 303 SS
 Internal components: SS and Brass
 Mobile: (STS)
 Body: 303 SS
 Internal components: Cast Aluminium and SS

Flow Capacities:

All suitable for use with oil, water and oil/water emulsion
 Size 0: 0.5-7 GPM (6-25 l/min)
 Size 1: 5-26 GPM (20-100 l/min)
 Size 2: 21-100 GPM (80-380 l/min)

Max. Working Pressure:

6,000 PSI (420 bar)

Capability:

Reverse flow (STI only)

Pressure Drop:

At max. rated flow, Δp is 16 psi (1.1 bar), mineral oil fluid at 30 cSt 140 SSU

Ports:

Size 0: G6
 Size 1: G12
 Size 2: G20

Repeatability:

$\pm 1\%$ FSD

Accuracy:

Flow $\pm 2.5\%$ full scale deflection*

Weight:

Size 0: 1.2 lbs. (0.5kg)
 Size 1: 8.4 lbs. (3.5kg)
 Size 2: 9 lbs. (4.4kg)

Aggressive Fluid Applications:

EPDM internal/external seals



Dimensions inches (mm)

	Size	Model	AØ	B	C
Industrial	0	STI	1.18 (30)	3.74 (95)	2.20 (56)
	1	STI	1.61 (41)	5.39 (137)	2.62 (66.5)
	2	STI	2.63 (66.7)	9.11 (231.3)	2.89 (73.5)
Mobile	1	STS	1.61 (41)	4.13 (105)	3.11 (79)
	2	STS	2.36 (60)	6.5 (165)	3.82 (97)

Ordering Information

Standard products table

Product Name	Supersedes	Size	Flow Range (GPM)	Fluid Type	SAE Port Threads	Reverse Flow Capability
STI0144100	STI.0344.100	0	.5-7	Mineral	SAE-6	Yes
STI1144100	STI.1344.100	1	5-26	Mineral	SAE-12	Yes
STI2144100	STI.2344.100	2	21-100	Mineral	SAE-20	Yes
STI0148100	STI.0348.100	0	.5-7	Aggressive	SAE-6	Yes
STI1148100	STI.1348.100	1	5-26	Aggressive	SAE-12	Yes
STI0248100	STI.2348.100	2	21-100	Aggressive	SAE-20	Yes
STS5117210	STS.5117.210	1	5-26	Mineral	SAE-12	No
STS5217210	STS.5217.210	2	21-100	Mineral	SAE-20	No

Note 1: Part numbers featured with bold highlighted codes will ensure a 'standard' product selection.
 Note 2: Alternate displayed part number selection will require you to contact Parker Filtration for availability.
 Note 3: Mobile Sensors are also available - Contact Parker
 Note 4: *Accuracy 5.5% > 25 gpm. (Applies to STI1144100 and STI1148100 only)

System20

Electronic Monitor Specification

Construction:

A sealed assembly requiring no routine maintenance or adjustment. Body molding in ABS. Key pad molded in silicon rubber. The monitor is suitable for use with all mineral oils, water and oil/water emulsions.

Display Details

Flow section:

The analog flow scale has reverse flow and overflow indication and provides a percentage reading of the digital full scale display automatically calibrated for all sizes of System 20 Sensor.

Pressure Section:

Designed to indicate line pressure, differential pressure and rising peak pressure. Connected to a System 20 Sensor it will monitor pressure up to 6,000 PSI (420 bar) with an accuracy of $\pm 1\%$ FSD.

Temperature Section:

Temperature reading between 14°F to 230°F (-10°C and +110°C).

Weight:

3 lbs. (1.4kg)

Data Logging:

Each test logs the following data:
Test number; time & date; sensor size; media tested; flow rate, pressure & temperature.

Data Download:

The System 20 electronic monitor is capable of downloading saved test data to a compatible PC via an RS232 connection using datum.

Batteries:

6 x AA batteries.

Re-calibration:

Annual certification by an approved Parker Service Center.

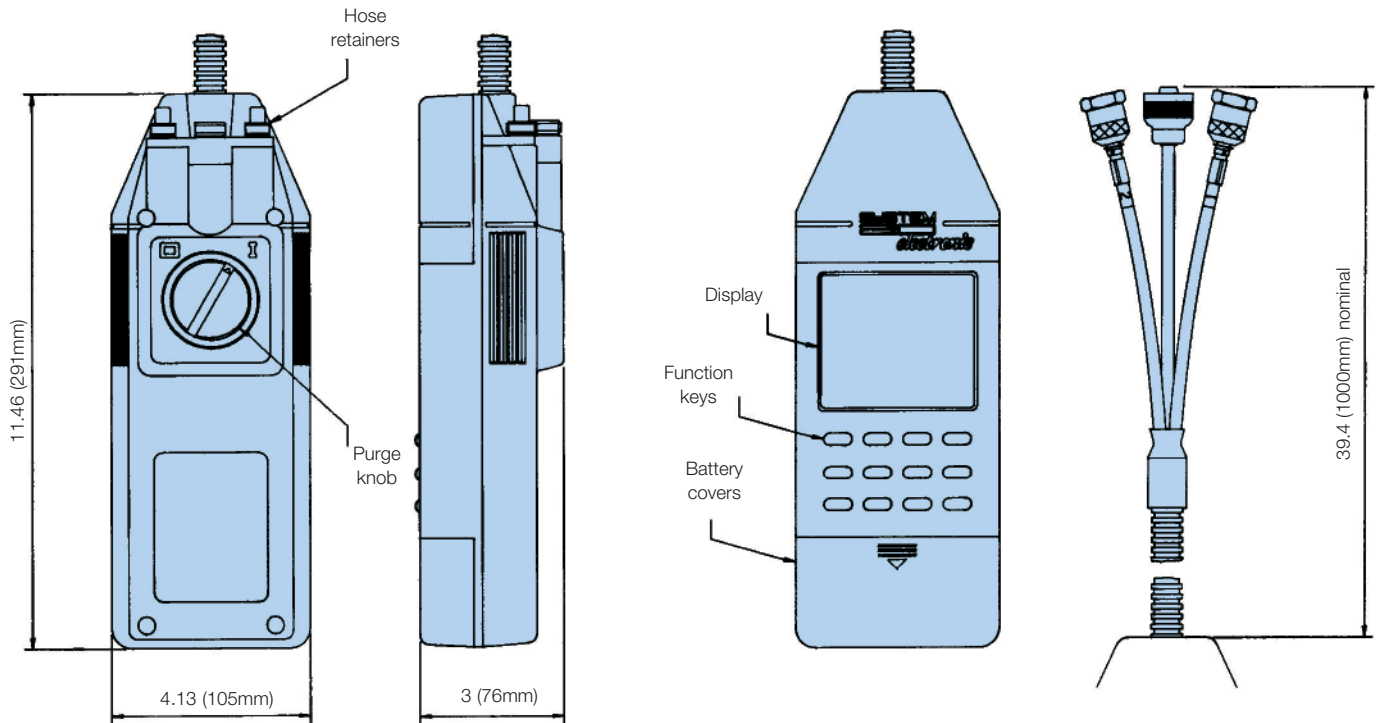

dimensions in inch (mm)

Ordering Information

Standard products table

Part Number	Supersedes	Description
EM209000	EM20.9000	System 20 electronic monitor
ACC6NK000	P653607	Transit case*
ACC6NJ001	B85617	Dongle and cable assembly*

* Not included with monitor.

System20

Analog Monitor

Construction:

A sealed assembly requiring no routine maintenance or adjustment. Body moulding in ABS. The monitor is suitable for use with all mineral oils, water and oil/water emulsions. The monitor has 3 dayglo dial gauges and features a protective hinged cover.

Display Details

Flow Section:

The flow scale has double scales for size 1 and 2 sensors only. Calibrated up to 26 GPM (100 l/min) and 100 GPM (380 l/min). The flow dial has excess-flow indication.

When the system is in reverse flow or when the high pressure lines to the sensor have been transposed, a 'below zero' indication is given.

Pressure Section:

Dial readings in both bar and psi up to 6,000 PSI (420 bar).

Temperature section:

The temperature dial gives readings between 14°F to 230°F (-10°C and +110°C).

Weight:

3 lbs. (1.4kg)

A viscosity chart is provided for mineral oil applications where monitoring is required at variable viscosities (cSt).

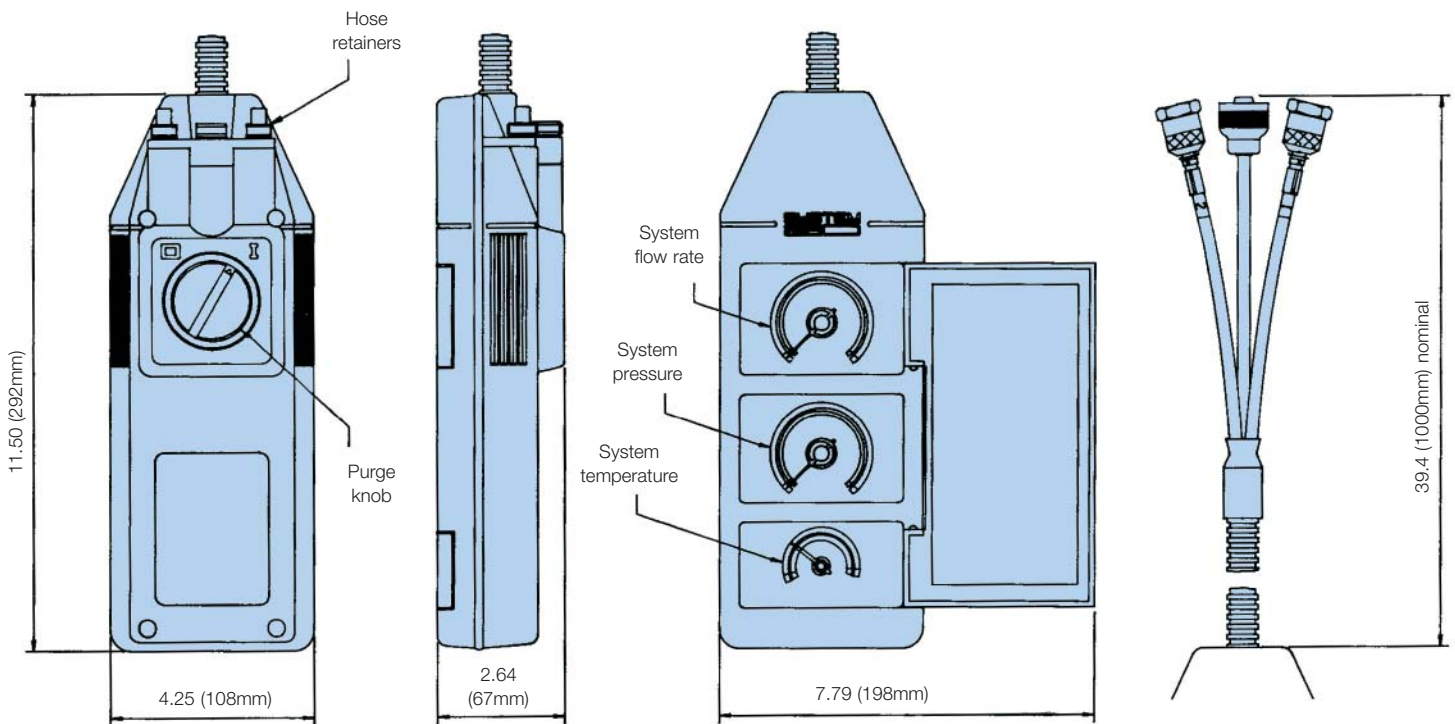

dimensions in inch (mm)

Ordering Information

Standard products table

Part Number	Supersedes	Media Type	Flow Readings	Pressure Readings	Temperature Readings
STM6211110	STM.6211.110	Oil	l/min	Dual scale PSI/bar	Dual scale°F/°C
STM6611110	STM.6611.110	Oil	GPM	Dual scale PSI/bar	Dual scale°F/°C
STM6211120	STM.6211.120	Water	l/min	Dual scale PSI/bar	Dual scale°F/°C
STM6611120	STM.6611.120	Water	GPM	Dual scale PSI/bar	Dual scale°F/°C

Accessories

Product Number	Supersedes	Description
ACC6NJ000	P653607	Transit Case
ACC6NJ002	P653106	Metal sensor protective cap



aerospace
 climate control
 electromechanical
filtration
 fluid & gas handling
 hydraulics
 pneumatics
 process control
 sealing & shielding

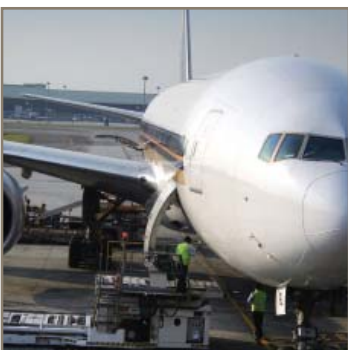

icountPD

Online Particle Detector



ENGINEERING YOUR SUCCESS.

icountPD

The icountPD from Parker represents the most up-to-date technology in solid particle detection.



The design dynamics, attention to detail, and small size of the permanently mounted, on-line particle detector brings a truly innovative product to all industry. The laser based, leading-edge technology is a cost effective market solution to fluid management and contamination control.

3 Versions Available

Standard icountPD is designed for test stand, flushing skids, filter carts and other industrial applications.

icountPDR is designed for mobile equipment or any outside use other than hazardous environment.

icountPDZ is intended for applications that require a Zone II safety such as off-shore platforms or any other hazardous environment.

For Zone I applications the standard icountPD can be used within a NEMA7 enclosure.



icountPDR

Features and benefits of the icountPD include:

- Independent monitoring of system contamination trends.
- Early warning LED or digital display indicators for Low, Medium and High contamination levels.
- Moisture % RH LED indicator (optional).
- Cost effective solution in prolonging fluid life and reducing machine downtime.
- Visual indicators with power and alarm output warnings.
- Continuous performance for dependable analysis.
- Hydraulic, phosphate ester & fuel fluid compatible construction.
- Self diagnostic software.
- Fully integrated PC/PLC integration technology such as:
RS232 and 0-5 Volt, 4-20mA, and CANBUS J1939.

Typical Applications

Mobile Equipment

- Earth Moving Machinery
- Harvesting
- Forestry
- Agriculture

Power Generation

- Wind Turbines
- Gearboxes
- Lubrication Systems

Industrial Equipment

- Production Plants
- Fluid Transfers
- Pulp & Paper
- Refineries

Maintenance

- Test Rigs
- Flushing Stands



icountPD/icountPDR/icountPDZ

Diagnostic self check start-up time	5 seconds
Measurement period	5 to 180 seconds
Reporting interval through RS232	0 to 3600 seconds
Digital LED display update time	Every second
Limit relay output	Changes occur +/- 1 ISO code at set limit (Hysteresis ON) or customer set (Hysteresis OFF)
4-20mA output signal	Continuous
Principle of operation	Laser diode optical detection of actual particulates
Reporting codes	ISO 7 – 21, NAS 0 – 12, (AS 00 – 12 contact Parker) Icount will also report less than ISO 7, subject to the statistical uncertainty defined in ISO4406:1999, which is shown in the RS232, reporting results as appropriate e.g “>6”
Calibration	By recognized on-line methods, confirmed by the relevant International Standards Organization procedures
Calibration recommendation	12 months (24 months for icountPDZ)
Performance	+/- 1 ISO Code (dependant on stability of flow)
Reproducibility / Repeatability	Better than 1 ISO Code
Power requirement	Regulated 9 to 40Vdc
Maximum current draw	150mA
Hydraulic connection	icountPD: M16 x 2 hydraulic test points (5/8” BSF for aggressive version) icountPD Z2: Size: 066, Connection: EO 24 cone end
Flow range through the device	40 to 140 ml/min (optimum flow = 60ml/min)
Online flow range via System 20 Inline Sensors	Size 0 = 1.59 to 6.6 gpm - (optimum flow = 3.96 gpm) Size 1 = 6.34 to 26.4 gpm - (optimum flow = 18.5 gpm) Size 2 = 44.9 to 100 gpm - (optimum flow = 66 gpm)
Required differential pressure across Inline Sensors	5.8 psi (0.4 bar) minimum
Viscosity range	10 to 500 cSt, 1 to 500 cSt
Temperature (icountPD and icountPDR)	Operating environment: -4°F to +140°F (-20°C to +60°C) Storage: -40°F to +176°F (-40°C to +80°C) Operating fluid: +32°F to +185°F (0°C to +85°C)
Temperature (icountPDZ)	Operating environment: -22°F to +140°F (-30°C to +60°C) Storage: -40°F to +176°F (-40°C to +80°C) Operating fluid: +41°F to +176°F (+5°C to +80°C)
Working pressure	30 to 6,000 PSI (2 to 420 bar)
Moisture sensor calibration	±5% RH (over compensated temperature range of +10°C to +80°C)
Operating humidity range	5% RH to 100% RH
Moisture sensor stability	±0.2% RH typical at 50% RH in one year
Certification	IP66 rated (icountPD), IP69K (icountPDZ) EMC/RFI –EN61000-6-2:2001(icountPD, PDR), EN6100-6-2:2005 (icountPDZ) EN61000-6-3:2001(icountPD, PDR), EN61000-6-3:2007 (icountPDZ)
Materials	Stainless Steel case construction (icountPDZ) Stainless Steel hydraulic block (icountPD and icountPDR) Viton seals, (icountPDZ: fluorocarbon seals)
Dimensions	icountPD: 7.2” x 6.1” x 3.4” (182mm x 155mm x 86mm) icountPDR: 4.52” x 7.01” x 4.53” (114.7mm c 178.8mm x 115mm) icountPDZ: 10.2” x 4.49” x 4.33” (260mm x 114mm x 110mm)
Weight	icountPD: 2.9 lbs. (1.3 kg), icountPDZ: 5.73 lbs. (2.6 kg)
Default Settings	See table on page 39

icountPD

Dimensions / Installation Details

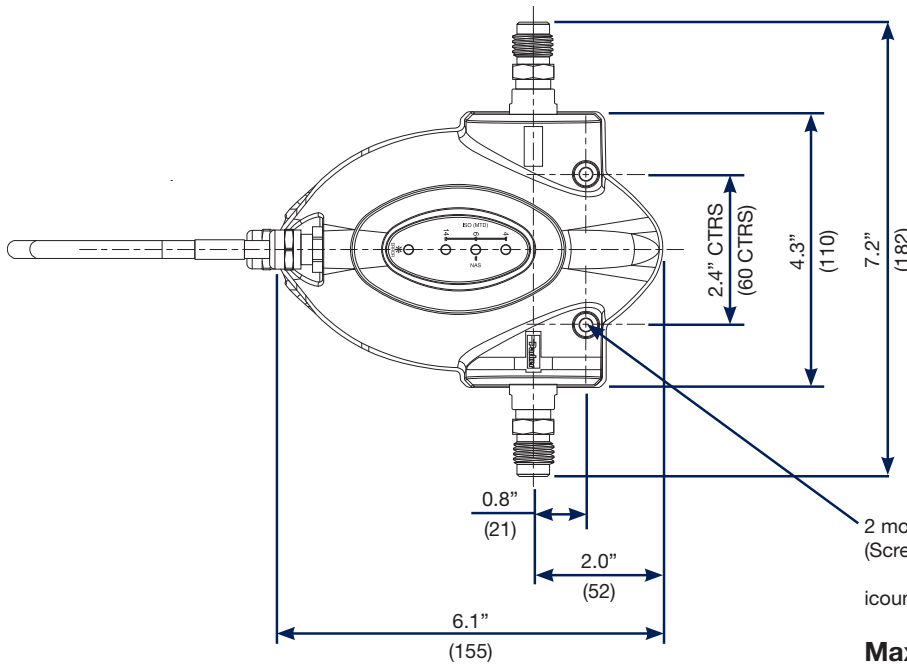
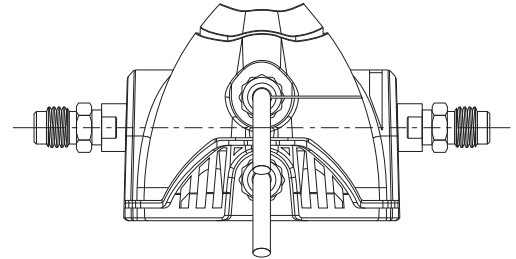
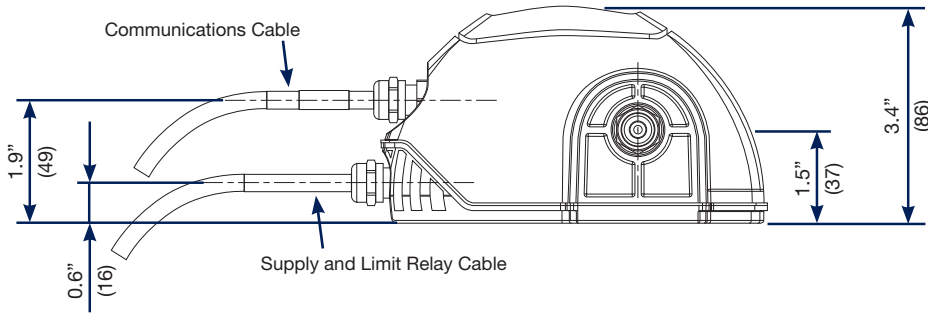

2 mounting locations to suit M5 socket head cap screw. (Screw pack supplied with icountPD)

icountPD flange thickness = 0.4" (10mm)

Maximum Torque 5Nm

dimensions in inch (mm)

*Limit Relay Wiring Instructions

NORMALLY OPEN
 NORMALLY CLOSED
 COMMON

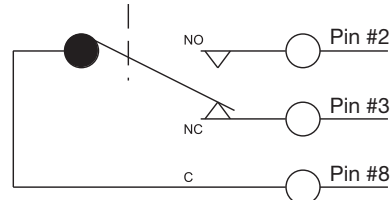

icountPD

Variable mA Output Settings

The following table can be used to equate the analog output for channels A, B, and C independently.

Example: ISO code 12 is equal to 10mA.

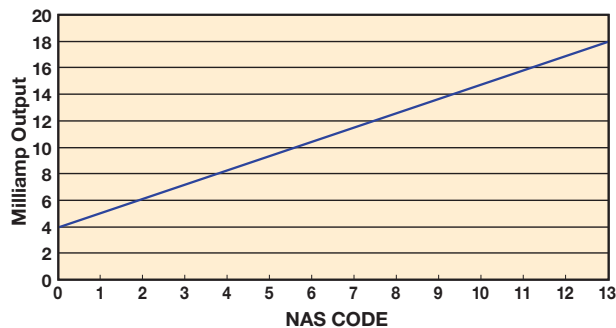
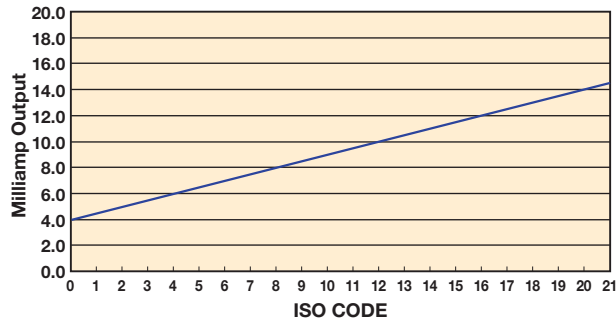

mA	ISO
4.0	0
4.5	1
5.0	2
5.5	3
6.0	4
6.5	5
7.0	6
7.5	7
8.0	8
8.5	9
9.0	10
9.5	11
10.0	12
10.5	13
11.0	14
11.5	15
12.0	16
12.5	17
13.0	18
13.5	19
14.0	20
14.5	21
15.0	**
15.5	**
16.0	**
16.5	**
17.0	**
17.5	**
18.0	**
18.5	**
19.0	OVERRANGE
19.5	OVERRANGE
20.0	ERROR

mA	NAS
4	00
5	0
6	1
7	2
8	3
9	4
10	5
11	6
12	7
13	8
14	9
15	10
16	11
17	12
18	**
19	**
20	ERROR

4-20mA output settings

ISO Setting

mA current = (ISO Code / 2) + 4
eg. 10mA = (ISO 12 / 2) + 4

or

ISO Code = (mA current - 4) * 2
eg. ISO 12 = (10mA - 4) * 2

NAS Setting

mA current = NAS Code + 5
eg. 15mA = NAS 10 + 5

or

NAS Code = mA current - 5
eg. NAS 10 = 15mA - 5

Variable Voltage Output Settings

The variable voltage output option has the capability of two different voltage ranges: a 0-5Vdc range as standard, and a user-selectable 0-3Vdc range.

The full list of commands on how to change the voltage output is available from Parker.

The following tables can be used to relate the analog output to an ISO or NAS code.

For example, in a 0-5Vdc range, ISO code 16 is equal to an output of 3.5Vdc. In a 0-3Vdc range, ISO code 8 is equal to an output of 1.0Vdc.

Table relating ISO codes to voltage output

ISO	Err	0	1	2	3	4	5	6	7	8	9	10	11
0-5Vdc	<0.2	0.3	0.5	0.7	0.9	1.1	1.3	1.5	1.7	1.9	2.1	2.3	2.5
0-3Vdc	<0.15	0.2	0.3	0.4	0.5	0.6	0.7	0.8	0.9	1.0	1.1	1.2	1.3

ISO	12	13	14	15	16	17	18	19	20	21	22	Err
0-5Vdc	2.7	2.9	3.1	3.3	3.5	3.7	3.9	4.1	4.3	4.5	4.7	>4.8
0-3Vdc	1.4	1.5	1.6	1.7	1.8	1.9	2.0	2.1	2.2	2.3	2.4	>2.45

Table relating NAS codes to voltage output

ISO	Err	00	0	1	2	3	4	5	6	7	8	9	10	11	12	Err
0-5Vdc	<0.4	0.6	0.9	1.2	1.5	1.8	2.1	2.4	2.7	3.0	3.3	3.6	3.9	4.2	4.5	>4.6
0-3Vdc	<0.2	N.S.	0.3	0.5	0.7	0.9	1.1	1.3	1.5	1.7	1.9	2.1	2.3	2.5	2.7	>2.8

icountPD

Display Parameters (ISO 4406/NAS 1638)

Digital display indication

The digital display will show the actual measured codes, the channel (μ) size and the user definable limits. Visible display of the channel size and user definable limits will alternate.

The moisture sensor reading (%RH) will also be shown – if the moisture sensor option is fitted.

The order of trigger for both of the codes and moisture sensor option is:

- Solid digit(s) = code(s) that are at or below the set point (limit)

- Flashing digit(s) = code(s) that are above the set point (limit)

The display for ISO4406 and NAS1638 are identical. The ISO display is shown below.



LED display indication

The LED display uses 3 sets of LED for the indication of ISO 4406 and NAS1638 code figures. Individual code lights will trigger based on the customer settings.

The order of trigger will be:

- Solid green = one ISO code, or better, below the set point (limit)
- Blinking green = ISO code at the set point (limit)
- Solid red = one ISO code above the set point (limit)
- Blinking red = two ISO codes, or more, above the set point (limit)

Moisture sensor output settings

The moisture sensor is an option that can be included when specifying the icountPD. The moisture sensor reports on the saturation levels of the fluid passing through the icountPD sensing cell. The output is a linear scale, reporting within the range of 5% saturation to 100% saturation.

Saturation	4-20mA	0-3Vdc	0-5Vdc
5%	4.8	0.15	0.25
25%	8	0.75	1.25
50%	12	1.50	2.50
75%	16	2.25	3.75
100%	20	3.00	5.00

icountPD

Auxiliary Flow Device

This simple to use flow control device fits on the downstream (outlet) side of the icountPD and is fitted with a differential pressure valve that adjusts the system flow to a range inside the icountPD specifications.

The flow control device will operate correctly between 150 psi (10.3 bar) and 2900 psi (200 bar) and the return back to an open system of 0 psi (0 bar) (DP = 2900 psi, 200 bar).



P/N ACC6NN019

Optional Accessories					
Description	Part Number		IPD	IPDR	IPDZ
	Mineral/Fuel	Phosphate Esters			
1 Meter Hose Length	ACC6NN001	ACC6NN002	X		
2 Meter Hose Length	ACC6NN003	ACC6NN004	X		
5 Meter Hose Length	ACC6NN005	ACC6NN006	X		
1/4" BSP Test point	ACC6NN007	ACC6NN008	X		
1/8" BSP Test point	ACC6NN009	ACC6NN010	X		
1/8" NPT Test point	ACC6NN011	ACC6NN012	X		
Single Point Sampler	SPS2021	SPS2061	X	X	X
US Power Supply	ACC6NE010		X	X	X
European Power Supply	ACC6NN013		X	X	X
5 meter, M12, 8-pin plug and socket cable kit*	ACC6NN014	ACC6NN015	X		
Deutsch 12-pin connector kit	ACC6NN016		X	X	
RS232 to USB converter	ACC6NN017		X	X	X
12" long M12 8-way RS232 & power cable kit	ACC6NN018		X		X
External Flow Device	ACC6NN019		X	X	X
M12, 12 way cable	ACC6NN024			X	

* Cable Kit consists of two 5 meter cables to enable all output options (Communications cable and Relay/Power Supply cable).

icountPDZ

ATEX Approved Online Particle Detector



For use in explosive and hazardous areas

The icountPD Particle Detector from Parker represents the most up to date technology in solid particle contamination analysis. This compact, permanently mounted laser-based ATEX approved particle detector module is designed for use in Zone II areas and is housed in a robust Stainless Steel IP69K approved enclosure that provides a cost effective solution to fluid management and contamination control.



Product Features:

- Independent monitoring of system contamination trends.
- Assembled in an approved and certified Stainless Steel enclosure to comply with ATEX Directive 94/9/EC.
- Can be used in explosive and hazardous areas.
- ATEX Zone II.
- Certified to CE Ex II 3GD, Ex nA IIC T4 Gc, Ex tc IIIC Dc SIRA 09ATEX4340X and IECEx SIR 09.0137X (-30°C < Ta < +60°C).
- Moisture & %RH indicator (optional).
- Warning limit relay outputs for low, medium and high contamination levels.
- Continuous performance for prolonged analysis.
- Self diagnostic software.
- Full PC/PLC integration technology such as:- RS232 and 0-5Volt, 4-20mA, CAN(J1939) (Contact Parker for other options).
- Set up and Data logging support software included.

icountPD

Ordering Information

BOX 1	BOX 2	BOX 3	BOX 4	BOX 5	BOX 6	BOX 7	BOX 8
IPD	1	2	2	2	2	1	30

BOX 1: Basic Assembly

Symbol	Description
IPD	Standard Particle Detector
IPDR	Particle Detector - Robust Construction
IPDZ	Particle Detector - Hazardous (Zone 2)

BOX 2: Fluid Type^{1,2}

Symbol	Description
1	Mineral Oil
2	Phosphate Ester (iPD, iPDR only)
3	Aviation Fuel (4 channel) (iPD, iPDZ only)

BOX 3: Calibration

Symbol	Description
2	MTD

BOX 4: Display

Symbol	Description
1	None (iPDR, iPDZ only)
2	LED (iPD only)
3	Digital (iPD only)

BOX 5: Limit Relay

Symbol	Description
1	No (iPDR only)
2	Yes

BOX 6: Communication^{3,4}

Symbol	Pressure Setting
2	RS232 / 4-20mA
3	RS232 / 0-5V (iPD, iPDR only)
5	RS232 / CAN-bus (J1939)

BOX 7: Moisture

Symbol	Description
1	No
2	Yes

BOX 8: Cable Connector⁵

Symbol	Description
10	Deutsch DT Series (iPD, iPDR only)
30	M12, 8-pin plug connector (iPD, iPDZ only)
40	M12, 12-pin plug connector (iPDR only)

Standard Default Settings for all icountPDs	
Comms echo	OFF
Verbose errors	OFF
STI Sensors used	OFF
Reporting standards	ISO
Particle limits	19/18/15
Measurement period	60 seconds
Reporting interval	30 seconds
Power-on mode	AUTO
Auto start delay	5 seconds
Date Format	dd/mm/yy
Default if Options Fitted	
Relay hysteresis	ON
Relay operation for particle limits	ON
Relay operation for moisture sensor limits	ON
Digital display orientation	0 degrees
Digital display brightness level	3-mid
0-5V/0-3V output voltage range	0-5V
Moisture sensor limit	70%

Notes:

- When "3" is selected in Box 2, "1" must be selected in Box 7.
- Aviation Fuel option can also be used for diesel fluids.
- For iPD and iPDR units, when "5" is selected in Box 6, "10" must be selected in Box 8.
- Contact Parker for additional communication options (RS485, GPRS, LAN, WiFi, Sat, etc.)
- The required connecting cables are available as a kit. The kit consists of two 5 meter cables (Communications cable and Relay/Power Supply cable) to enable all output options. See Accessory table on page 37 for applicable part number.



aerospace
 climate control
 electromechanical
filtration
 fluid & gas handling
 hydraulics
 pneumatics
 process control
 sealing & shielding



icount Oil Sampler (IOS)

Portable Condition Monitoring for Hydraulic Oil and Fuel Systems

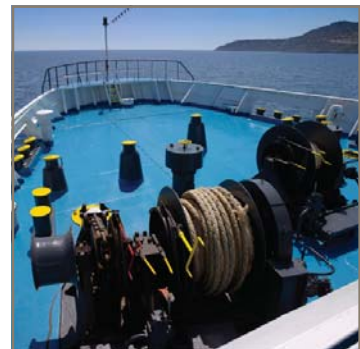

ENGINEERING YOUR SUCCESS.

Accurate Condition Monitoring made Quick, Simple and Cost Effective

The icountOS (IOS) is an innovative solution to the challenge of measuring the quality of hydraulic oils and hydrocarbon fuels in many different applications: from renewable energy, marine and offshore, to manufacturing, mobile, agriculture, military and aerospace.

Compact, lightweight and robust, the truly portable IOS makes field analysis simple, quick and easy.

Able to sample directly from a hydraulic reservoir, barrel, vehicle fuel tank or from a high pressure online hydraulic system with the addition of a pressure reducing adaptor; the IOS is undoubtedly the most adaptable contamination service tool available today.

The system is completely self contained, with laser detection particle counter, battery and pump plus memory with web page generator for data download onto any PC or laptop - combined into a single unit.

The IOS uses Parker's proven laser detection technology, which delivers precise, repeatable, reproduceable results, in real time detection of both particulates, down to 4 microns and dissolved water.

Just as importantly, the IOS has been developed to offer a wealth of features, combined with simplicity and ease of use, at a cost that is far lower than competing systems, and which fits within most maintenance budgets.



Powerful and easy to use



Lightweight and portable

Wherever, Whenever you need to be 100% sure of Oil and Fuel Quality

With its robust carrying case, sealed to IP67, and proven laser and diagnostics technologies, the IOS is the perfect tool for maintenance and plant engineers to use with all fixed and mobile plant and machinery.

IOS technology is proven in many different applications, under the most demanding conditions, and is used by leading companies around the world.



In the construction and mining sector, IOS is ideally suited to service and fluid monitoring of essential equipment and services.



In the defence industry, IOS provides essential condition monitoring support for mission critical front line battle tanks and military vehicles.



The IOS is the primary diagnostic instrument to help automotive manufacturers develop predictive monitoring programs.



Ease of on-site use, light weight and portability are key IOS features for monitoring fuel quality in military bulk fuel installations in theatre.



Accuracy and speed of use make the IOS ideal for wind turbine engineers, for both routine maintenance and emergency repairs, flushing and commissioning.



In the aviation sector, the ability to meet strict quality controls makes the IOS the ideal choice for ground handling support companies, ensuring clean and dry fuel deliverance.

icountOS

How It Works

The IOS quality condition monitor for hydraulic oils and hydrocarbon fuels uses advanced technology to produce extremely repeatable results.

At the heart of the system is a sophisticated laser detector, using a light obscuration flow cell, providing continuous measurement of fluid flow passing through a sample tube.

Measurements are taken every second as standard, although measurement intervals and test period can be defined by the user, with results being reported immediately and updated in real time.

Data is displayed on a built-in OLED digital display and can also be stored for subsequent upload via the embedded icount's web page interface connecting through an RJ45 cable.

Proven Laser Detection Technology

Parker's experience in developing laser light obscuration or blockage and applying that technology in portable particle counting and detection is what makes Parker's range of contamination analyzers so very special.



Hydraulic Circuit

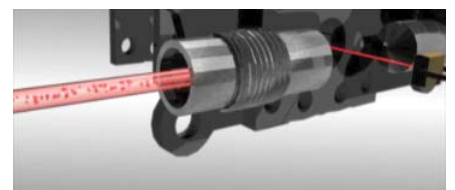
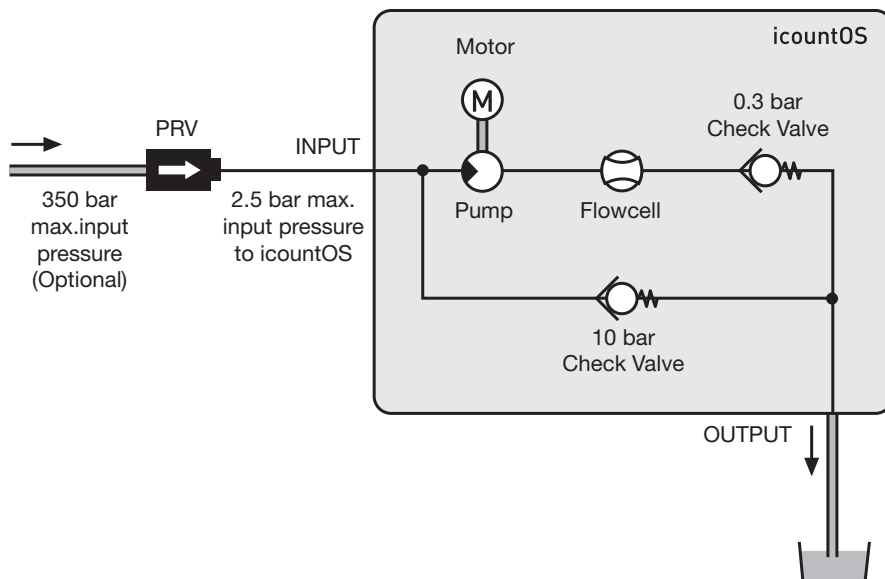

Fig 1. In simple terms a controlled column of contaminated fluid enters the laser optical scanner chamber. This design maintains contamination distribution within the fluid.

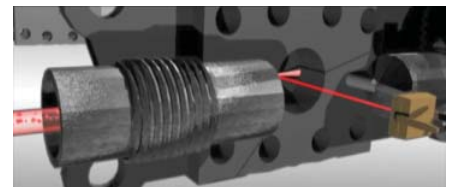

Fig 2. On reaching the photo diode cell, the highly accurate laser light is applied and projected through that oil column. The laser diode projects an image of the sample onto a photo diode cell.



Fig 3. A cast image or shadow created by the contaminant in the oil creates a measurable change in the light intensity.

icountOS

dimensions are in mm (inches)

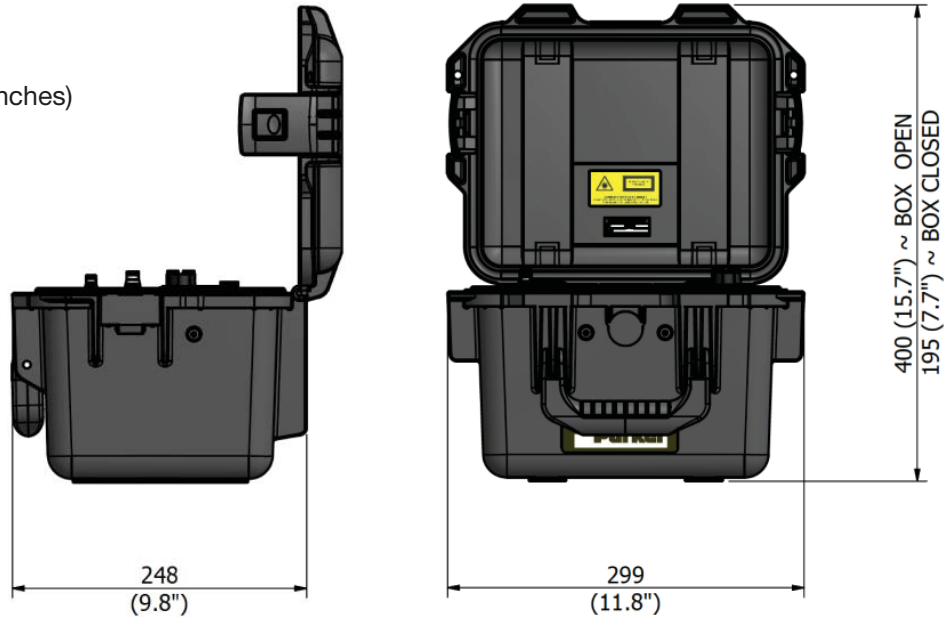

Low Pressure Connection Setup

We recommend that the IOS is positioned in a safe, stable area, as close as possible to the system output and only the hose fittings provided are used.

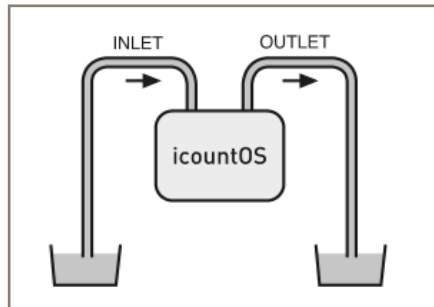

Option 1

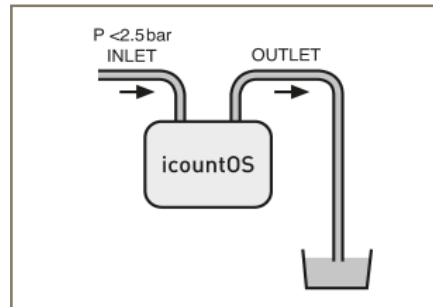

Option 2

High Pressure Connection Setup (Optional equipment needed)

(High pressure is defined for this unit as more than 2.5 bar, with a maximum of 350 bar)

We recommend that the IOS is positioned in a safe, stable area, as close as possible to the system output and only the hose fittings provided are used. For pressure systems (more than 2.5 bar) one high pressure hose assemblies: ACC6NN034, and a Pressure Reducing Valve (PRV) ACC6NN027 are required.

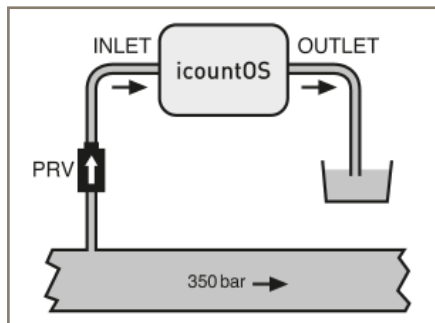

Attach OUTLET (Ø 4mm) hose



To remove the PRV, press down on the removal tool at the same time as lifting PRV off.

icountOS

Features

Proven Laser Detecton Technology

The IOS uses light obscuration, light blockage technology. A light source is projected through a moving column of oil or fuel. Contaminants in the fluid interrupt the light beam, casting images on a photo diode cell, where the resulting change in light intensity produces a directly proportional change in electrical output.



High Onboard Test Data Storage Capacity

Class leading onboard memory provides storage capacity for up to 250,000 sets of test results. Data is displayed instantly, stored or downloaded to a PC or laptop for analysis via a standard IP68 RJ 45 patch cord connection; a 2m cable is supplied as standard. (File types - text/CSV or XMI)

Quick Connection

Connecting the IOS is quick and reliable. The fluid connectors are on the front panel, with two secure push fittings: .236" diameter (6mm) inlet and .157" diameter (4mm) outlet/drain. Parker can supply dedicated hoses and fittings for use with most hydraulic and hydrocarbon fluids.

Tough Storm Case

The robust waterproof IP54 (when open) case and fully sealed impact resistant brushed stainless steel front panel provide excellent protection in the most demanding of applications. The combined unit weighs under 12.1 lb (5.5kg), making it an ideal 'first use' diagnostic service tool.

Fast Contamination Detection

The IOS provides fast detection of the presence of contaminants, with the results being shown on the front panel mounted, high visibility OLED digital display. This provides easy identification of fluid condition, showing measured codes, the sizes per channel in microns, the user definable limits and moisture sensor readings as a % of relative humidity.

Complies with the Latest Standards

The IOS is designed in accordance with the latest global standards including:

- CE marking
- EC Declaration of Conformity
- Machinery Directive
- EMC EN61000-6-3:2001
- EMC EN61000-6-2:2001
- EN 61010-1:2001

Long Life Remote Operation

The IOS uses a long life regulated 12 Vdc power supply, with an M12, 4 pin connector, plus a rechargeable NiMH detector battery unit for use onsite or in remote locations.

Fluid and Pressure Control

The IOS automatically adjusts flow rates, to an optimum level of 60ml/min. Total flow range is between 40 and 140ml/min, with maximum online operating pressure being 36 psi (2.5Bar). An optional inlet reduction valve is also available for high pressure applications.

Pressure Reducing Valve (PRV)

A pressure compensated PRV device (Parker Hannifin part number ACC6NN027) has been developed to enable testing where flow pressures in the hose exceeds 35 psi (2.5 bar), up to a maximum of 5000 psi (350 bar).



Parameter	Value
Working pressure range	0 to 35 psi (2.5 bar)
Working pressure with PRV	35 psi (2.5) to 5000 psi (350 bar)
Working viscosity	1 to 300 cSt



Results are viewed in the OLED digital display window



High Pressure Connection

Manual Connection: Press the Pressure Reducing Valve firmly into the **INLET** port.



Low Pressure Connection

Connect **INLET** .236" Ø (6mm) hose.

icountOS

Web Interface

The IOS is a unique product in that it has its own web page generator which means that the stored data can be downloaded or viewed on any PC or laptop.

Utilizing a computer's Internet Explorer utility, simply plug in the supplied network cable, open Explorer and enter the IOS's unique IP/MAC address.

Home Page

Key

1. Product description
2. Key features
3. Register the product at www.parker.com/unlock

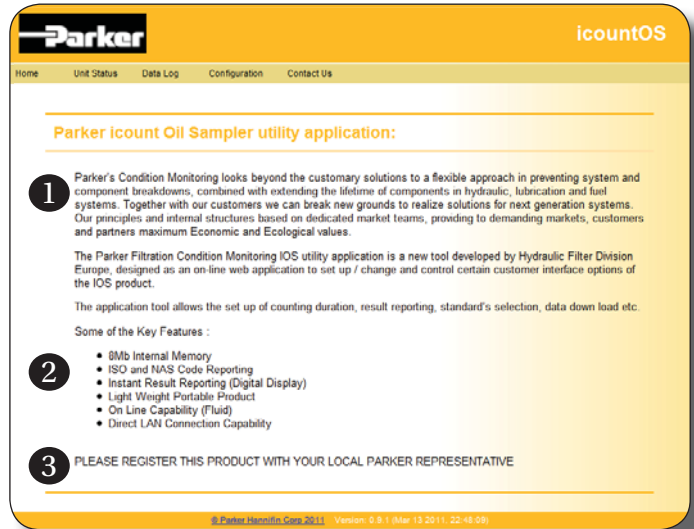

Data Log Page

Key

1. Start and Stop data logging
2. Save data in one of three date formats:
 - TXT format
 - CSV (Comma Separated Variables)
 - XML (eXtended Markup Language)
3. Clear data logging memory
4. List of the five last samples taken
5. Memory usage

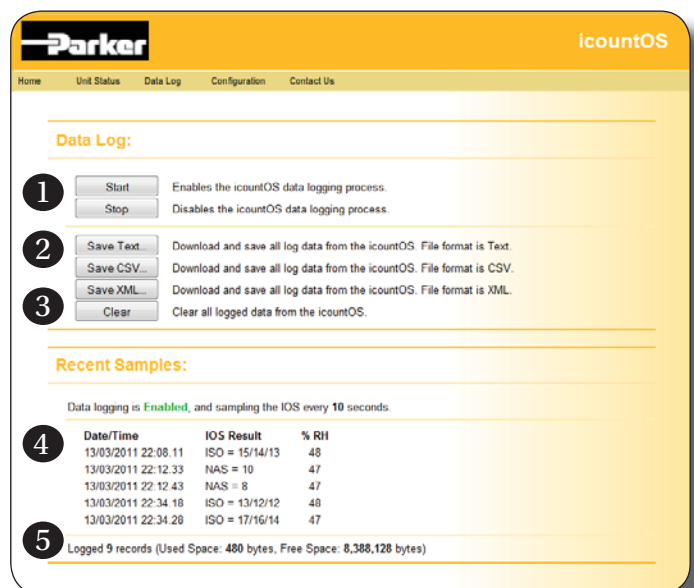

icountOS

Web Interface

Unit Status Page

Key

1. The Unit Status page is a list of current values for various parameters for the connected IOS unit.

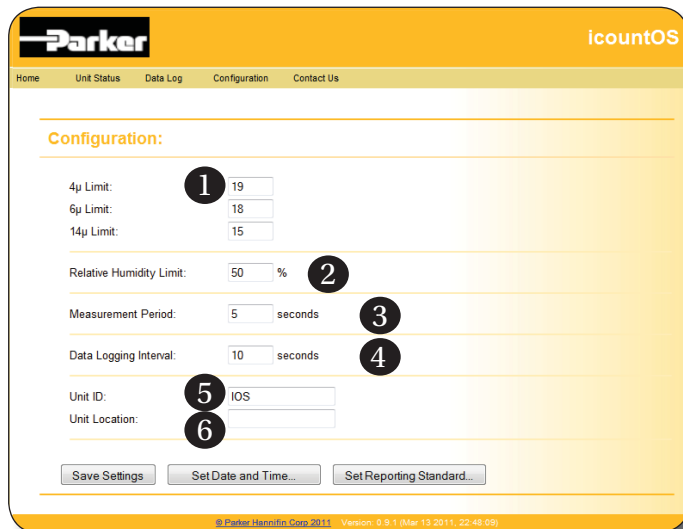
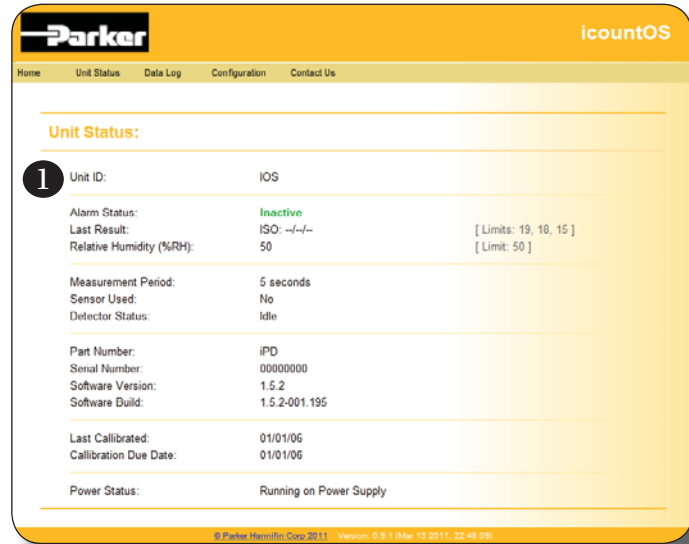

Configuration Page

Key

1. Alarm limit settings for:
 - 4µm channel
 - 6µm channel
 - 14µm channel
2. Alarm limit setting for Relative Humidity
3. Measurement period
4. Data logging interval
5. Unit name
6. Unit location

Configuration: Set Report Standard Page

Key

1. Select either the ISO4406:1999 or NAS1638 standard.
2. Confirm the selected standard.



icountOS

Specifications

Feature	Specification
Product start-up time	10 seconds minimum
Measurement period	Default 30 seconds run time; 15 seconds data logging time
Reporting interval	Onboard data storage every second. Output via RJ45 connection
Principle of operation	Laser diode optical detection of actual particulates
International codes range	Up to ISO 22 (+/- 1 ISO code) NAS 0-12
Calibration	Calibration by recognized online methods confirmed by the relevant ISO procedures. MTD – via a certified primary ISO 11171 automatic particle detector using ISO 11943 principles. Particle distribution reporting to ISO 4406:1999
Recalibration and Servicing	Recommended every 12 months
Working pressure	35-5000 psi (2.5–350 bar) Pressures above 35 psi require the use of a Parker Pressure Reducing Valve (PRV) – ACC6NN027
Working viscosity	1-300 cSt
Flow range through IOS	40–140ml/minute; controlled at 60ml/min by IOS's internal pump
Fluid connection interface	INLET: .236 inch (6mm) push-fit. DRAIN: .157 inch (4mm) push-fit
Ambient storage temperature for unit	–40°C to +80°C; –40°F to +176°F
Operating temperature for unit	–30°C to +80°C; –22°F to +176°F
Operating humidity range	5%RH to 100%RH
Fluid operating temperature (Oil)	+5°C to +80°C; +41°F to +176°F
Fluid operating temperature (Fuel)	–20°C to +70°C; –4°F to +158°F
Moisture sensor	Linear scale within the range 5%RH to 100%RH
Computer compatibility	IP68-rated RJ45 connection that may be connected to a laptop computer's RJ45 LAN port using the 2m cable supplied
Power requirement	Regulated power supply supplied with the unit
Certification	IP54 rating (unit open) IP67 rating (unit closed) EC Declaration of Conformity Machinery Directive EMC EN61000-6-3:2001 EMC EN61000-6-2:2001 EMC EN61010-1:2001 CE Certified

What is included?

Offline IOS 1210 EUR/UK/US	Online IOS 1220 EUR/UK/US
1x IOS Oil Sampler Unit	1x IOS Oil Sampler Unit
+ 1x Power Supply	+ 1x Power Supply
+ 1x RJ45 LAN Cable	+ 1x RJ45 LAN Cable
+ Low Pressure Hoses	+ 1x Low Pressure Hose
	+ 1x PRV
	+ 1x High Pressure Hose

Important Information

WARNING-USER RESPONSIBILITY

FAILURE OR IMPROPER SELECTION OR IMPROPER USE OF THE PRODUCTS DESCRIBED HEREIN OR RELATED ITEMS CAN CAUSE DEATH, PERSONAL INJURY AND PROPERTY DAMAGE.

- This document and other information from Parker-Hannifin Corporation, its subsidiaries and authorized distributors provide product or system options for further investigation by users having technical expertise.
- The user, through their own analysis and testing, is solely responsible for making the final selection of the system and components and assuring that all performance, endurance, maintenance, safety and warning requirements of the applications are met.
- The user must analyze all aspects of the application, follow applicable industry standards, and follow the information concerning the product in the current product catalog and in any other materials provided from Parker or its subsidiaries or authorized distributors.
- To the extent that Parker or its subsidiaries or authorized distributors provide component or system options based upon data or specifications provided by the user, the user is responsible for determining that such data and specifications are suitable and sufficient for all applications and reasonably foreseeable uses of the components or systems. The operation of the products described here in is subject to the operating and safety procedures details of which are available upon request.

Sales conditions

The items described in this document are available for sale by Parker Hannifin Corporation, its subsidiaries or its authorized distributors. Any sale contract entered into by Parker will be governed by the provisions stated in Parker's standard terms and conditions of sale (copy available upon request).

icountOS

How To Order

Key	Fluid Type	Calibration	Connection	Options
IOS1220EUR	Mineral	MTD	Online	No options
IOS1210EUR	Mineral	MTD	Offline	No options

Key	Fluid Type	Calibration	Connection	Options	Region
IOS	1 Mineral	2 MTD	1 Offline	0 No options	UK
	3 Aviation fuel (4 channels*)		2 Online		EUR
					USA

*Fluid Type 3: Contact Parker Hannifin

Accessory Part Numbers

Description	Part number
-------------	-------------

Hose Kit Bag (includes one power pack, RJ45 patch cable and low pressure hose connectors)



ACC6NN029UK
ACC6NN029EUR
ACC6NN029US

Description	Part number
-------------	-------------

RJ45 LAN Connector Cable



ACC6NE028

Pressure Reducing Valve (PRV)



ACC6NN027
(Standard with IOS 1220)

Carry Strap



ACC6NN030
The Carry Strap option MUST be selected at the time of placing the IOS order.

Power Pack (UK 2m cable)



ACC6NE023

Low Pressure Hoses (4mm and 6mm)



ACC6NN031

Power Pack (EUR 2m cable)



ACC6NE024

High Pressure Hose Assembly



ACC6NN034
(Standard with IOS 1220)

Power Pack (US 2m cable)



ACC6NE025

Verification Fluid



SER.MISC.067

icountMS Range

Moisture Sensors



Fast, reliable and accurate inline detection of moisture in fluids

MS moisture sensors provide fast, reliable and accurate inline detection of moisture in fluids. Technology developed for preventative maintenance programmes. MS200 is the 'Programmable' sensor monitoring and reporting relative humidity (RH), moisture content in oils. MS300 'Intrinsically safe' sensor ATEX certified for use in hazardous Zone 0 environments.



Product Features

- MS moisture sensors provide fast, reliable and accurate inline detection of moisture in fluids.
- Technology developed for preventative maintenance programs.
- MS200 'Programmable' sensor monitoring and reporting relative humidity (RH), moisture content in oils. 6,000 PSI (420 bar) MAOP.
- MS300 'Intrinsically safe' sensor ATEX certificated for use in hazardous Zone 0 environments. 6,000 PSI (420 bar) MAOP.
- Temperature Outputs on all versions.

icountMS Range

Features and Benefits

- Continuous, online moisture indication, for hydraulic and lubricating systems.
- Reporting of % relative humidity of water content, giving the user information on how close to the fluids real saturation point.
- Reliable data on the rate of water absorption.
- Sensing cell technology using a laser trimmed thermoset polymer, for capacitive sensing that is capable of absorbing water molecules due to its micro porous structure.
- Uses a thermistor for temperature compensation correction. Offering total confidence in reporting the %RH relative humidity over the sensors temperature range.
- A purpose designed tee adaptor allows for easy installation into an existing fluid system.
- The MS200 can also be specified with a bench top wand offering the end user greater flexibility.

Typical Applications

- Ground support vehicles
- Pulp and paper plants
- Marine hydraulics
- Power transmission & distribution
- Forestry
- Industrial hydraulics
- Earth moving applications
- Agricultural
- Hazardous Areas (Zone II)
- Simulators



In-Line Moisture Measurement of Hydraulic & Lubricating Fluids.

Parkers Moisture Sensor Range offers fast, reliable and accurate in-line detection of moisture in fluids. The MS transducer type technology has been especially designed with the preventative maintenance programme environment in mind.

The industry accepted sensing cell device will monitor and report Relative Humidity (RH), moisture content in oils. The water content measurement technique offers the end user benefits over the current standard form of water content reporting (PPM).

This allows for real time preventative maintenance to be undertaken and corrective actions to be made. By knowing that the water contamination is still within the oils absorbing range, less than 100%, reclaiming fluid properties before additive damage occurs can initiate calculable cost savings.

MS200 Moisture Sensor

Specifications

% Saturation Calibration Accuracy:	+3% RH
Temperature Calibration Accuracy:	±1°C
Thermal Stability:	±1% RH (over compensated temperature range +10 to +80°C)
Stability:	±0.2% RH typical at 50% RH in 1 year
Linearity:	±0.5% RH typical
Analog Output Hysteresis:	±0.5% RH Full Scale
Switched Output Hysteresis:	2% RH
Operating Temperature Range:	-40°F to +185°F (-40°C to +85°C)
Operating Humidity Range:	5 to 100% RH (non condensing)
Response Time:	60 sec in slow moving air at 25°C
Maximum Rated Pressure:	6,000 PSI (420 Bar)
Maximum Torque:	22 ft-lbs
Seal Material (depending on MS):	Fluorocarbon, EPDM, Perfluoroelastomer
Material:	Stainless Steel 303
Connector Details:	M12x1, 8 Way, IP67 Connector (IP68 when mated with molded cable)
Maximum Cable Length:	33 ft (10 m) with Voltage Output, 330 ft (100 m) with current output
Output:	SEE ORDERING INFORMATION

Installation Details

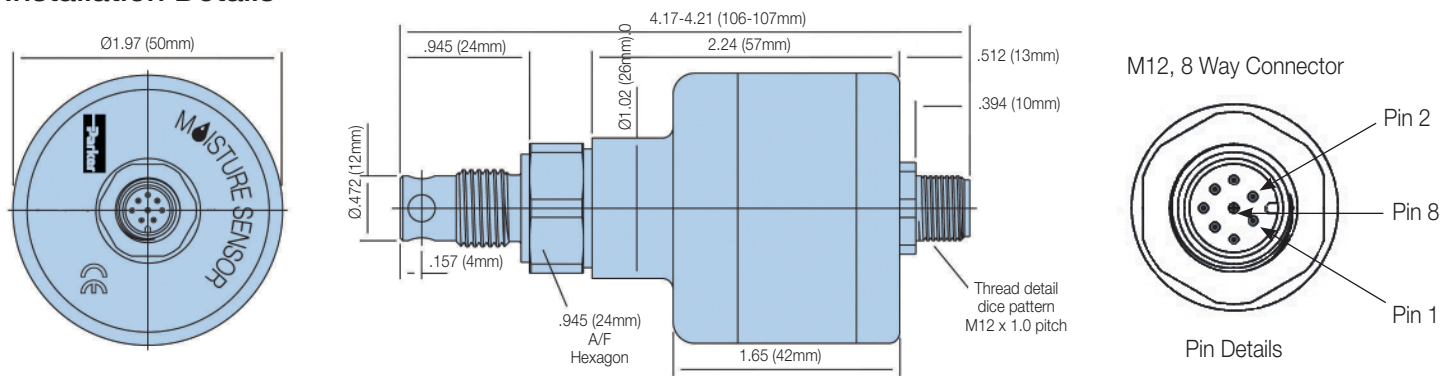

Moisture Sensor Wiring and Pin Designations

dimensions in inch (mm)

Pin	Wire Colour	Designation	I/O	Description
1	White	Alarm Switch	Output	Alarm Switch. Constant 5Vdc when in normal operation. Switch to 0Vdc when in alarm condition. Red LED illuminates when Sensor is in an alarm condition.
2	Brown	Analogue	Output	Temperature - Degí Celsius. User Select Output (0-3Vdc, 0-5Vdc, 1-6Vdc and 4-20mA).
3	Green	Alarm Limit	Output	Alarm Limit (0-6V). Output that directly corresponds to the alarm set point.
4	Yellow	Analogue	Output	% Saturation. User Select Output (0-3Vdc, 0-5Vdc, 1-6Vdc and 4-20mA).
5	Grey	Receive	Input	RS232 Communication.
6	Pink	Send	Output	RS232 Communication.
7	Blue	Common	Input	Common (0Vdc). Ground from power supply.
8	Red	Supply	Input	Supply Voltage (+8 to +30Vdc). Green LED illuminates when power is properly applied.

MS300 Intrinsically Safe

Specifications

Pressure:

(MAOP): 6,000 PSI (420 bar)

Operating temperature:

Minimum: -40°F (-40°C) - dependent on seal material
Maximum: +185°F (+85°C)

Flow through sensor cell:

Installed in active flowstream

Fluid compatibility:

Mineral oils, petroleum-based and Phosphate ester-Skydrol option available

Viscosity range:

Unlimited

Thread form connections:

See ordering information

Outputs:

4-20mA (current loop)

Calibration accuracy:

+/- 5% RH

Compensated thermal stability:

+/- 1% RH (+ 50°F to +176°F)

Materials:

Stainless steel 303

Sensor size/weight:

4.21in x ø1.97in/0.66 lb (107mm x ø50mm/0.3Kg)

IP ratings:

IP68 (with specified molded cable)

Developed in association with Triteq Ltd.

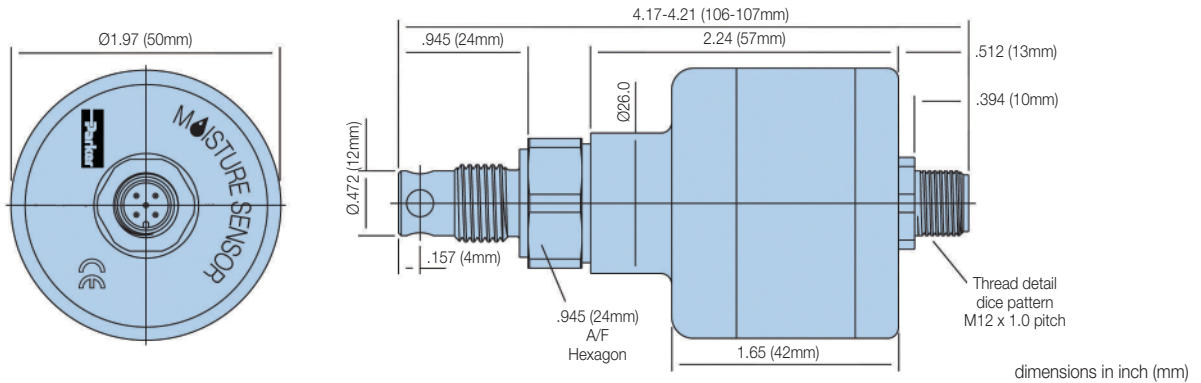

Ex II 1G
Ga Ex ia IIB T4
Sira 07ATEX2255
IECEX SIR 07.0089

CE 0518

Moisture Sensor Connection Diagram

- | | |
|---------------------------|---------|
| 1. Supply (4-20 mA - IN) | - Brown |
| 2. Signal (4-20 mA - OUT) | - White |
| 3. Not Used | - Blue |
| 4. Not Used | - Black |
| 5. Not Used | - Grey |

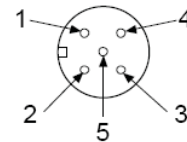

The MS300 has been certified as Intrinsically Safe Electrical Apparatus and offers fast, reliable and accurate in-line detection of moisture in fluids for use in hazardous areas.

ATEX Certification allows the MS300 into areas of a potentially explosive atmosphere, that have previously not been allowed without permits, it is intended for use in Zone 0 hazardous areas requiring the use of category 1G equipment and has been designed for use with galvanic isolators to the specified values stated below:

The electrical parameters: Ui: 28V li: 93mA Pi:0.65W Ci: 380nF Li: 0

The following instructions apply to MS300 - 4-20mA Current Loop Moisture Sensor covered by certificate number Sira 07ATEX2255:

1. The equipment may be located where flammable gases of Group I may be present. The equipment is only certified for use in ambient temperatures in the range -4°F to +104°F (-20°C to +40°C) and should not be used outside this range.
2. The equipment has not been assessed as a safety-related device (as referred to by Directive 94/9/EC Annex II, clause 1.5).
3. Installation of this equipment shall be carried out by suitably trained personnel in accordance with the applicable code of practice.
4. Repair of this equipment shall be carried out by the manufacturer or in accordance with the applicable code of practice (IEC 60079-19).

Moisture Sensor Displays

Specifications

Bar Graph Indicator (PBG8341A)

Construction:

Housing – nylon 6/6, window – acrylic, bezel/board supports – ABS, pins – phosphor bronze

Power supply:

11 – 30 Vdc

Signal input: (By dipswitch configuration)

Off – differential up to 5V

A – single signal (Ref. 0V) up to 5V

B – single signal (Ref. 1V) up to 6V

Cut out size:

45.6mm x 45.6mm

Fixing:

Push fit panel thickness 0.9mm to 3.2mm

Sealing:

Designed to IP50 standard.

(Front face may be silicon sealed after LED configuration)

Scale:

Supplied 0 to 100% in horizontal

Other scales, in volume, consult Parker Hannifin

Scaling factors:

10% to 100% range. Fully adjustable

Lamp intensity:

4mcd each

Front viewing:

Polarized

Weight:

29gms

Alternative Indicator

Description	DDU1001	DDU1002
Power supply	11 - 30 Vdc	110 - 240 Vdc
Accuracy	± 0.1% typical	± 0.1% typical
Sample rate	2.5 per second	2.5 per second
Operating temp (°C)	0 - 50	0 - 50
Storage temp (°C)	-10 to +70	-10 to +70
Display	N3.5 digit LEDA	3 1/2 digit LED
Power output (Vdc)	24	24
Weight (kg)	0.30	0.30
Panel cutout (mm)	93x45 ± 0.5	93x45 ±/0.5
Dimensions (mm)	48x96x93	48x96x93



PBG8341A



DDU1001/DDU1002

Product accessories part numbers

Product Number	Supersedes	Description
DDU1001	P.9732PVC-10	Digital display unit 22-55 Vdc
DDU1002	P.9732PVC-05	Digital display unit 110-240 Vdc
PBG8341A	PBG.8341.1A	Bar Graph Indicator (+11 to +30 Vdc)
PAM8342	PAM.8342	Bar Graph alarm module
ACC6NF000	B97200	5 meter M12, 8 pin molded cable (IP68)
ACC6NF001	P973200	M12, 5 pin rewirable connector (IP65)
ACC6NF002	S970410	10 meter extension box
ACC6NE008	S970400	UK 12 volt power supply
ACC6NE009	S970400	European 12 volt power supply
ACC6NE010	S970400	US 12 volt power supply
ACC6NF003	N/A	5 meter M12, 5 pin molded cable (IP68)

Moisture sensor output setting

The Moisture sensor reports on the saturation levels of the fluid passing through the sensing cell. The output is a linear scale, reporting within the range of 5% saturation to 100% saturation.

Saturation	4–20mA	0–3Vdc	0–5Vdc
5%	4.8	0.15	0.25
25%	8	0.75	1.25
50%	12	1.50	2.50
75%	16	2.25	3.75
100%	20	3.00	5.00

Ordering Information

MS200 - Product Configurator

Key	Model	Fluid Type	Output Options	Thread Forms	Connector	Future Option
MS	2 Programmable	2 Mineral	01 0 - 3 Vdc	1 G 1/4" BSP Bonded Seal	1 M12 8 Way	0 No
			02 0 - 5 Vdc	2 G 1/4" BSP Integral Seal		
		03 1 - 6 Vdc	3 R 1/4" Taper			
		04 4 - 20 mA	4 1/4" NPT Taper			
		5 9/16 - 18 UNF 2A Integral Seal				
		6 Hand Held Unit				
		7 G 3/8" BSP Female Swivel Equal T Adaptor				

MS300 - Product Configurator

Key	Model	Fluid Type	Output Options	Thread Forms	Connector	Future Option
MS	3 Programmable	2 Mineral	04 4 - 20 mA	1 G 1/4" BSP Bonded Seal	1 5 Way	0 No
				2 G 1/4" BSP Integral Seal		
		3 R 1/4" Taper				
		4 1/4" NPT Taper				
		5 9/16 - 18 UNF 2A Integral Seal				
		6 G 3/8" BSP Female Swivel Equal Tee				

Oilcheck

Hand-held Oil Condition Monitor



Portable and battery powered for 'go-anywhere' monitoring

Hand-held condition monitor provides a visual comparison between new and used oils

Parker's Oilcheck is completely portable and battery powered with a numerical display that indicates positive or negative increase in dielectrics. Oilcheck gives an early warning of impending failure and the simplistic hand-held design makes it easy to use.



Product Features

- Oilcheck hand-held condition monitor provides a visual comparison between new and used oils.
- Completely portable and battery powered.
- Numerical display shows positive or negative increase in dielectrics.
- Gives early warning of impending failure.

Oilcheck

Features & Benefits

- A comparator between new and used oils.
- Oilcheck gives early warning of impending failure.
- Cost effective solution to save money and help improve system reliability.
- Completely portable, battery powered.
- Ideal for reliability, engineers, and maintenance personnel.
- Numerical display to show positive or negative increase in dielectrics.

Using Oilcheck

Following the simple sampling procedure, Parker's Oilcheck will ensure effective and highly repeatable results. Once a clean oil sample has been placed in the 'Sensor Well' and the 'TEST' button has been pressed, the instrument will 'zero' on the sample.

Once cleaned out with a suitable solvent, such as petroleum ether, and replaced by a contaminated sample, a new reading is obtained on the LCD, which can be easily compared against the green/amber/red efficiency scale.

Typical Applications

- Fleet Maintenance Garages
- Construction equipment maintenance
- Plant maintenance

The Oilcheck from Parker detects and measures the dielectric constant of oil, by comparing the measurements obtained from used and unused oils of the same brand.

Used as a regular service monitoring instrument, the Oilcheck will give the user warning of fluid degradation and promote increased system component life.

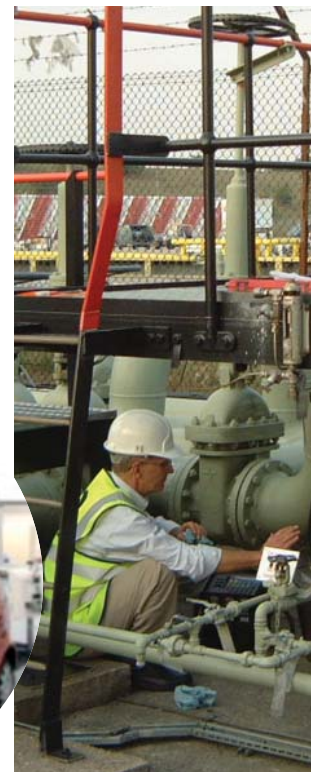

Oilcheck

Specifications

Case construction:

ABS

Circuitry:

Microprocessor control

Battery:

1 x 9V alkaline (supplied)

Display:

LCD

Suitable oil types:

Mineral and synthetic based oils

Repeatability:

Better than 5%

Readout:

Green/amber/red grading, Numerical value (0-100%)

Battery lifetime:

>150 hours or 3,000 tests

Dimensions:

9.8" x 3.7" x 1.3" (250mm x 95mm x 34mm)

Weight:

0.4kg

Using Oilcheck



Green/amber/red numerical value

The Oilcheck can remove the need for costly and time consuming laboratory analysis of mineral and synthetic oils used in hydraulics, gear boxes, bearing lubrication systems, and engines. It detects wear debris and any loss of lubricating properties in the oil.



Function buttons

The Oilcheck is able to show changes in the oil condition brought about by the ingress of water content, metallic content, and fuel contamination.

Installation Details

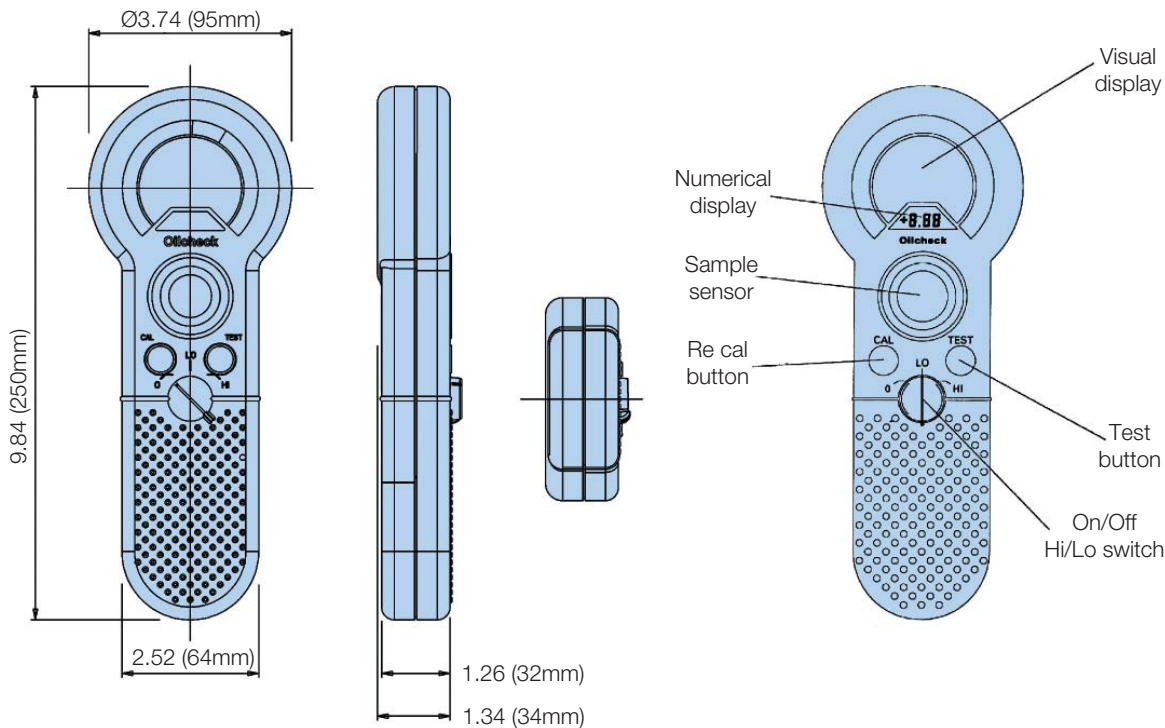

dimensions in inch (mm)

Ordering Information

Standard products table

Product Number	Description
OLK605	Oilcheck kit with numerical readout

Note: Petroleum ether can be used as a between sample cleaner.

Guide to Contamination Standards

This guidebook is aimed at engineers, technicians and quality control personnel involved in contamination control. Its purpose is to make available accepted and widely-used cleanliness specification levels for liquid samples.

The tables in this guide allow users of using automatic portable particle counters to see the relationship between raw particle counts at various sizes and the reporting code numbers of various contamination standards.

A NOTE ON THE FIGURES USED

Note that some of the table entries are defined as cumulative counts (e.g. “> 6 μ m”) and others are defined as differential counts (e.g. 6–14 μ m”).

Instances of particle sizes given as “ μ m” refer to ACFTD (i.e. Air Cleaner Fine Test Dust) distributions. Instances of particle sizes given as “ μ m(c)” refer to MTD (i.e. ISO Medium Test Dust) distributions.

All standards are in counts per volume, and provide easy methods for converting particle counts into limits that are simple to interpret. By noting the requirements of the standard, particle counts can be accurately converted to contamination levels.

ISO Cleanliness Code

Hydraulic Fluid Contamination

ISO code number	Number of particles per ml	
	More than	Up to and including
22	20,000	40,000
21	10,000	20,000
20	5,000	10,000
19	2,500	5,000
18	1,300	2,500
17	640	1,300
16	320	640
15	160	320
14	80	160
13	40	80
12	20	40
11	10	20
10	5	10
09	2.5	5
08	1.3	2.5
07	0.64	1.3

Suggested Acceptable Contamination Codes

ISO code numbers	Type of system	Typical components	Sensitivity
23 / 21 / 17	Low pressure systems with large clearances	Ram pumps	Low
20 / 18 / 15	Typical cleanliness of new hydraulic oil straight from the manufacturer. Low pressure heavy industrial systems or applications where long-life is not critical	Flow control valves Cylinders	Average
19 / 17 / 14	General machinery and mobile systems Medium pressure, medium capacity	Gear pumps/motors	Important
18 / 16 / 13	World Wide Fuel Charter cleanliness standard for diesel fuel delivered from the filling station nozzle. High quality reliable systems General machine requirements	Valve and piston pumps/motors Directional and pressure control valves	Very important
17 / 15 / 12	Highly sophisticated systems and hydrostatic transmissions	Proportional valves	Critical
16 / 14 / 11	Performance servo and high Pressure long-life systems e.g. Aircraft machine tools, etc.	Industrial servovalves	Critical
15 / 13 / 09	Silt sensitive control system with very high reliability Laboratory or aerospace	High performance servovalves	Super critical

NOTE: The three figures of the ISO code numbers represent ISO level contamination grades for particles of $>4\mu\text{m}(c)$, $>6\mu\text{m}(c)$ and $>14\mu\text{m}(c)$ respectively.

NAS 1638 Table

The NAS 1638 cleanliness standard was developed for aerospace components in the US and is still widely used for industrial and aerospace fluid power applications.

The figures are differential counts, and the NAS class is usually reported as a single figure representing the maximum allowed particle counts (i.e. worst case) for designated particle size ranges.

	Size range	5–15 µm	15–25	25–50	50–100	>100 µm
NAS classes (based on maximum contamination limits, particles per 100ml)	00	125	22	4	1	0
	0	250	44	8	2	0
	1	500	89	16	3	1
	2	1,000	178	32	6	1
	3	2,000	356	63	11	2
	4	4,000	712	126	22	4
	5	8,000	1,425	253	45	8
	6	16,000	2,850	506	90	16
	7	32,000	5,700	1,012	180	32
	8	64,000	11,400	2,025	360	64
	9	128,000	22,800	4,050	720	128
	10	256,000	45,600	8,100	1,440	256
	11	512,000	91,000	16,200	2,880	512
12	1,024,000	182,400	32,400	5,760	1,024	

SAE AS4059 rev E Table

Note that this standard is technically identical to ISO 11218.

	Maximum contamination limits (particles per ml)					
MTD	>4µm(c)	>6µm(c)	>14µm(c)	>21µm(c)	>38µm(c)	>70µm(c)
ACFTD	>2µm	>5µm	>15µm	>25µm	>50µm	>100µm
Size code	A	B	C	D	E	F
000	195	76	14	3	1	0
00	390	152	27	5	1	0
0	780	304	54	10	2	0
1	1,560	609	109	20	4	1
2	3,120	1,220	217	39	7	1
3	6,250	2,430	432	76	13	2
4	12,500	4,860	864	152	26	4
5	25,000	9,730	1,730	306	53	8
6	50,000	19,500	3,460	612	106	18
7	100,000	38,900	6,920	1,220	212	32
8	200,000	77,900	13,900	2,450	424	64
9	400,000	156,000	27,700	4,900	848	128
10	800,000	311,000	55,400	9,800	1,700	256
11	160,000	623,000	111,000	19,600	3,390	512
12	320,000	1,250,000	222,000	39,200	6,780	1,024

MTD ISO11171 (Calibration or optical microscope count – particle size based on projected area equivalent diameter)

ACFTD ISO4402 (Calibration or optical microscope count – particle size based on longest dimension)

GOST 17216-2001 Table

The GOST standard is developed by the Technical Committee of Standardization TK 184 “Ensuring Industrial Cleanliness” introduced by the Government of Russia.

Adopted by the Inter-governmental Committee of Standardization Metrology and Certification (Protocol No. 19 dated 24 May 2001).

	Size range	5–10µm	10–25µm	25–50µm	50–	>100µm
Particle contamination level by class (particles per 100ml)	00	8	4	1	0	0
	0	16	8	2	0	0
	1	32	16	3	0	0
	2	63	32	4	1	0
	3	125	63	8	2	0
	4	250	125	12	3	0
	5	500	250	25	4	1
	6	1,000	500	50	6	2
	7	2,000	1,000	100	12	4
	8	4,000	2,000	200	25	6
	9	8,000	4,000	400	50	12
	10	16,000	8,000	800	100	25
	11	31,500	16,000	1,600	200	50
	12	63,000	31,500	3,150	400	100
	13	–	63,000	6,300	800	200
	14	–	125,000	12,500	1,600	400
	15	–	–	25,000	3,150	800
16	–	–	50,000	6,300	1,600	
17	–	–	–	125,000	3,150	

NAV AIR 10-1A-17 Table

The Navy Standard for Hydraulic Fluids used for aircraft hydraulic systems is defined in the Aviation Hydraulics Manual (1989), Table 2-1, Navy Standard for Particulate Cleanliness.

NAVY STANDARD FOR HYDRAULIC FLUIDS – USED FOR AIRCRAFT HYDRAULIC SYSTEMS

Particle Contamination Level by Class							
Particle size in μm	0	1	2	3	4	5	6
	Number of particles per 100ml						
5–10	2,700	4,600	9,700	24,000	32,000	87,000	128,000
10–25	670	1,340	2,680	5,360	10,700	21,400	42,000
25–50	93	210	380	780	1,510	3,150	6,500
50–100	16	28	56	110	225	430	1000
>100	1	3	5	11	21	41	92

ISO/NAS/SAE Code Comparison Table

The comparisons relate to particle count data only. To conform to any particular standard, reference should be made to the recommended experimental procedure.

ISO/DIS 4406 BS 5540/4 codes	Defence Std. 05/42		NAS 1638	SAE 749
	Table A	Table B		
13 / 11 / 08			2	
14 / 12 / 09			3	0
15 / 13 / 10			4	1
16 / 14 / 09		400F		
16 / 14 / 11			5	2
17 / 15 / 09	400			
17 / 15 / 10		800F		
17 / 15 / 12			6	3
18 / 16 / 10	800			
18 / 16 / 11		1300F		
18 / 16 / 13			7	4
19 / 17 / 11	1300	2000		
19 / 17 / 14			8	5
20 / 18 / 12	2000			
20 / 18 / 13		4400F		
20 / 18 / 15			9	6
21 / 19 / 13	4400	6300F		
21 / 19 / 16			10	
22 / 20 / 13	6300			
22 / 20 / 17			11	
23 / 21 / 14	15,000			
23 / 21 / 18			12	
24 / 22 / 15	21,000			
25 / 23 / 17	100,000			

PPM Conversion Table

Percent contamination vs. PPM (parts per million)	
Percent	PPM
100%	1,000,000
10%	100,000
1%	10,000
0.1%	1,000
0.01%	100
0.001%	10

Volume	
1 litre	= 1 000ml
1 PPM	= 1 µl in 1 litre
Example 1	
400PPM in 1 litre	= 400µl
Example 2	
A reading of 250PPM equates to a quantity of absorbed water in a 400 litre capacity system of 0.1 litre.	

Offer of Sale

The items described in this document and other documents and descriptions provided by Parker Hannifin Corporation, its subsidiaries and its authorized distributors ("Seller") are hereby offered for sale at prices to be established by Seller. This offer and its acceptance by any customer ("Buyer") shall be governed by all of the following Terms and Conditions. Buyer's order for any item described in its document, when communicated to Seller verbally, or in writing, shall constitute acceptance of this offer. All goods or work described will be referred to as "Products".

1. Terms and Conditions. Seller's willingness to offer Products, or accept an order for Products, to or from Buyer is expressly conditioned on Buyer's assent to these Terms and Conditions and to the terms and conditions found on-line at www.parker.com/saleterms/. Seller objects to any contrary or additional term or condition of Buyer's order or any other document issued by Buyer.

2. Price Adjustments; Payments. Prices stated on the reverse side or preceding pages of this document are valid for 30 days. After 30 days, Seller may change prices to reflect any increase in its costs resulting from state, federal or local legislation, price increases from its suppliers, or any change in the rate, charge, or classification of any carrier. The prices stated on the reverse or preceding pages of this document do not include any sales, use, or other taxes unless so stated specifically. Unless otherwise specified by Seller, all prices are F.O.B. Seller's facility, and payment is due 30 days from the date of invoice. After 30 days, Buyer shall pay interest on any unpaid invoices at the rate of 1.5% per month or the maximum allowable rate under applicable law.

3. Delivery Dates; Title and Risk; Shipment. All delivery dates are approximate and Seller shall not be responsible for any damages resulting from any delay. Regardless of the manner of shipment, title to any products and risk of loss or damage shall pass to Buyer upon tender to the carrier at Seller's facility (i.e., when it's on the truck, it's yours). Unless otherwise stated, Seller may exercise its judgment in choosing the carrier and means of delivery. No deferment of shipment at Buyers' request beyond the respective dates indicated will be made except on terms that will indemnify, defend and hold Seller harmless against all loss and additional expense. Buyer shall be responsible for any additional shipping charges incurred by Seller due to Buyer's changes in shipping, product specifications or in accordance with Section 13, herein.

4. Warranty. Seller warrants that the Products sold hereunder shall be free from defects in material or workmanship for a period of twelve months from the date of delivery to Buyer or 2,000 hours of normal use, whichever occurs first. The prices charged for Seller's products are based upon the exclusive limited warranty stated above, and upon the following disclaimer: **DISCLAIMER OF WARRANTY: THIS WARRANTY COMPRISES THE SOLE AND ENTIRE WARRANTY PERTAINING TO PRODUCTS PROVIDED HEREUNDER. SELLER DISCLAIMS ALL OTHER WARRANTIES, EXPRESS AND IMPLIED, INCLUDING MERCHANTABILITY AND FITNESS FOR A PARTICULAR PURPOSE.**

5. Claims; Commencement of Actions. Buyer shall promptly inspect all Products upon delivery. No claims for shortages will be allowed unless reported to the Seller within 10 days of delivery. No other claims against Seller will be allowed unless asserted in writing within 60 days after delivery or, in the case of an alleged breach of warranty, within 30 days after the date within the warranty period on which the defect is or should have been discovered by Buyer. Any action based upon breach of this agreement or upon any other claim arising out of this sale (other than an action by Seller for any amount due to Seller from Buyer) must be commenced within thirteen months from the date of tender of delivery by Seller or, for a cause of action based upon an alleged breach of warranty, within thirteen months from the date within the warranty period on which the defect is or should have been discovered by Buyer.

6. LIMITATION OF LIABILITY. UPON NOTIFICATION, SELLER WILL, AT ITS OPTION, REPAIR OR REPLACE A DEFECTIVE PRODUCT, OR REFUND THE PURCHASE PRICE. IN NO EVENT SHALL SELLER BE LIABLE TO BUYER FOR ANY SPECIAL, INDIRECT, INCIDENTAL OR CONSEQUENTIAL DAMAGES ARISING OUT OF, OR AS THE RESULT OF, THE SALE, DELIVERY, NON-DELIVERY, SERVICING, USE OR LOSS OF USE OF THE PRODUCTS OR ANY PART THEREOF, OR FOR ANY CHARGES OR EXPENSES OF ANY NATURE INCURRED WITHOUT SELLER'S WRITTEN CONSENT, EVEN IF SELLER HAS BEEN NEGLIGENT, WHETHER IN CONTRACT, TORT OR OTHER LEGAL THEORY. IN NO EVENT SHALL SELLER'S LIABILITY UNDER ANY CLAIM MADE BY BUYER EXCEED THE PURCHASE PRICE OF THE PRODUCTS.

7. Contingencies. Seller shall not be liable for any default or delay in performance if caused by circumstances beyond the reasonable control of Seller.

8. User Responsibility. The user, through its own analysis and testing, is solely responsible for making the final selection of the system and Product and assuring that all performance, endurance, maintenance, safety and warning requirements of the application are met. The user must analyze all aspects of the application and follow applicable industry standards and Product information. If Seller provides Product or system options, the user is responsible for determining that such data and specifications are suitable and sufficient for all applications and reasonably foreseeable uses of the Products or systems.

9. Loss to Buyer's Property. Any designs, tools, patterns, materials, drawings, confidential information or equipment furnished by Buyer or any other items which become Buyer's property, may be considered obsolete and may be destroyed by Seller after two consecutive years have elapsed without Buyer placing an order for the items which are manufactured using such property. Seller shall not be responsible for any loss or damage to such property while it is in Seller's possession or control.

10. Special Tooling. A tooling charge may be imposed for any special tooling, including without limitation, dies, fixtures, molds and patterns, acquired to manufacture Products. Such special tooling shall be and remain Seller's property notwithstanding payment of any charges by Buyer. In no event will Buyer acquire any interest in apparatus belonging to Seller which is utilized in the manufacture of the Products, even if such apparatus has been specially converted or adapted for such manufacture and notwithstanding any charges paid by Buyer. Unless otherwise agreed, Seller shall have the right to alter, discard or otherwise dispose of any special tooling or other property in its sole discretion at any time.

11. Buyer's Obligation; Rights of Seller. To secure payment of all sums due or otherwise, Seller shall retain a security interest in the goods delivered and this agreement shall be deemed a Security Agreement under the Uniform Commercial Code. Buyer authorizes Seller as its attorney to execute and file on Buyer's behalf all documents Seller deems necessary to perfect its security interest. Seller shall have a security interest in, and lien upon, any property of Buyer in Seller's possession as security for the payment of any amounts owed to Seller by Buyer.

12. Improper use and Indemnity. Buyer shall indemnify, defend, and hold Seller harmless from any claim, liability, damages, lawsuits, and costs (including attorney fees), whether for personal injury, property damage, patent, trademark or copyright infringement or any other claim, brought by or incurred by Buyer, Buyer's employees, or any other person, arising out of: (a) improper selection, improper application or other misuse of Products purchased by Buyer from Seller; (b) any act or omission, negligent or otherwise, of Buyer; (c) Seller's use of patterns, plans, drawings, or specifications furnished by Buyer to manufacture Product; or (d) Buyer's failure to comply with these terms and conditions. Seller shall not indemnify Buyer under any circumstance except as otherwise provided.

13. Cancellations and Changes. Orders shall not be subject to cancellation or change by Buyer for any reason, except with Seller's written consent and upon terms that will indemnify, defend and hold Seller harmless against all direct, incidental and consequential loss or damage. Seller may change product features, specifications, designs and availability with notice to Buyer.

14. Limitation on Assignment. Buyer may not assign its rights or obligations under this agreement without the prior written consent of Seller.

15. Entire Agreement. This agreement contains the entire agreement between the Buyer and Seller and constitutes the final, complete and exclusive expression of the terms of the agreement. All prior or contemporaneous written or oral agreements or negotiations with respect to the subject matter are herein merged.

Offer of Sale

The items described in this document and other documents and descriptions provided by Parker Hannifin Corporation, its subsidiaries and its authorized distributors ("Seller") are hereby offered for sale at prices to be established by Seller. This offer and its acceptance by any customer ("Buyer") shall be governed by all of the following Terms and Conditions. Buyer's order for any item described in its document, when communicated to Seller verbally, or in writing, shall constitute acceptance of this offer. All goods or work described will be referred to as "Products".

16. Waiver and Severability. Failure to enforce any provision of this agreement will not waive that provision nor will any such failure prejudice Seller's right to enforce that provision in the future. Invalidation of any provision of this agreement by legislation or other rule of law shall not invalidate any other provision herein. The remaining provisions of this agreement will remain in full force and effect.

17. Termination. This agreement may be terminated by Seller for any reason and at any time by giving Buyer thirty (30) days written notice of termination. In addition, Seller may by written notice immediately terminate this agreement for the following: (a) Buyer commits a breach of any provision of this agreement (b) the appointment of a trustee, receiver or custodian for all or any part of Buyer's property (c) the filing of a petition for relief in bankruptcy of the other Party on its own behalf, or by a third party (d) an assignment for the benefit of creditors, or (e) the dissolution or liquidation of the Buyer.

18. Governing Law. This agreement and the sale and delivery of all Products hereunder shall be deemed to have taken place in and shall be governed and construed in accordance with the laws of the State of Ohio, as applicable to contracts executed and wholly performed therein and without regard to conflicts of laws principles. Buyer irrevocably agrees and consents to the exclusive jurisdiction and venue of the courts of Cuyahoga County, Ohio with respect to any dispute, controversy or claim arising out of or relating to this agreement. Disputes between the parties shall not be settled by arbitration unless, after a dispute has arisen, both parties expressly agree in writing to arbitrate the dispute.

19. Indemnity for Infringement of Intellectual Property Rights. Seller shall have no liability for infringement of any patents, trademarks, copyrights, trade dress, trade secrets or similar rights except as provided in this Section. Seller will defend and indemnify Buyer against allegations of infringement of U.S. patents, U.S. trademarks, copyrights, trade dress and trade secrets ("Intellectual Property Rights"). Seller will defend at its expense and will pay the cost of any settlement or damages awarded in an action brought against Buyer based on an allegation that a Product sold pursuant to this Agreement infringes the Intellectual Property Rights of a third party. Seller's obligation to defend and indemnify Buyer is contingent on Buyer notifying Seller within ten (10) days after Buyer becomes aware of such allegations of infringement, and Seller having sole control over the defense of any allegations or actions including all negotiations for settlement or compromise. If a Product is subject to a claim that it infringes the Intellectual Property Rights of a third party, Seller may, at its sole expense and option, procure for Buyer the right to continue using the Product, replace or modify the Product so as to make it noninfringing, or offer to accept return of the Product and return the purchase price less a reasonable allowance for depreciation. Notwithstanding the foregoing, Seller shall have no liability for claims of infringement based on information provided by Buyer, or directed to Products delivered hereunder for which the designs are specified in whole or part by Buyer, or infringements resulting from the modification, combination or use in a system of any Product sold hereunder. The foregoing provisions of this Section shall constitute Seller's sole and exclusive liability and Buyer's sole and exclusive remedy for infringement of Intellectual Property Rights.

20. Taxes. Unless otherwise indicated, all prices and charges are exclusive of excise, sales, use, property, occupational or like taxes which may be imposed by any taxing authority upon the manufacture, sale or delivery of Products.

21. Equal Opportunity Clause. For the performance of government contracts and where dollar value of the Products exceed \$10,000, the equal employment opportunity clauses in Executive Order 11246, VEVRAA, and 41 C.F.R. §§ 60-1.4(a), 60-741.5(a), and 60-250.4, are hereby incorporated.

Parker Hannifin Corporation

About Parker Hannifin Corporation

Parker Hannifin is a leading global motion-control company dedicated to delivering premier customer service. A Fortune 500 corporation listed on the New York Stock Exchange (PH), our components and systems comprise over 1,400 product lines that control motion in some 1,000 industrial and aerospace markets. Parker is the only manufacturer to offer its customers a choice of hydraulic, pneumatic, and electromechanical motion-control solutions. Our Company has the largest distribution network in its field, with over 12,000 distributors serving our customers around the world.

Parker's Charter

To be a leading worldwide manufacturer of components and systems for the builders and users of durable goods. More specifically, we will design, market and manufacture products controlling motion, flow and pressure. We will achieve profitable growth through premier customer service.

Product Information

North American customers seeking product information, the location of a nearby distributor, or repair services will receive prompt attention by calling the Parker Product Information Center at our toll-free number: 1-800-C-PARKER (1-800-272-7537). In the UK, a similar service is available by calling 0500-103-203.

The Aerospace Group

is a leader in the development, design, manufacture and servicing of control systems and components for aerospace and related high-technology markets, while achieving growth through premier customer service.



The Climate & Industrial Controls Group

designs, manufactures and markets system-control and fluid-handling components and systems to refrigeration, air-conditioning and industrial customers worldwide.



The Fluid Connectors Group

designs, manufactures and markets rigid and flexible connectors, and associated products used in pneumatic and fluid systems.



The Seal Group designs, manufactures and distributes industrial and commercial sealing devices and related products by providing superior quality and total customer satisfaction.



The Hydraulics Group

designs, produces and markets a full spectrum of hydraulic components and systems to builders and users of industrial and mobile machinery and equipment.



The Filtration Group

designs, manufactures and markets quality filtration and clarification products, providing customers with the best value, quality, technical support, and global availability.



The Automation Group

is a leading supplier of pneumatic and electro-mechanical components and systems to automation customers worldwide.



The Instrumentation Group

is a global leader in the design, manufacture and distribution of high-quality critical flow components for worldwide process instrumentation, ultra-high-purity, medical and analytical applications.



Parker Hannifin Corporation
Filtration Group
Global Headquarters
 6035 Parkland Boulevard
 Cleveland, OH 44124-4141
 T 216 896 3000, F 216 896 4021
www.parker.com

North America

Compressed Air Treatment
Filtration & Separation/Balston
 242 Neck Road
 Haverhill, MA 01835-0723
 T 978 858 0505, F 978 858 0625
www.parker.com/balston

Filtration & Separation/Finite
 500 Glaspie Street, PO. Box 599
 Oxford, MI 48371-5132
 T 248 628 6400, F 248 628 1850
www.parker.com/finitefilter

Purification, Dehydration and
Filtration Division
 4087 Walden Avenue
 Lancaster, NY 14086
 T 716 685 4040, F 716 685 1010
www.airtek.com
 Sales Office
 5900-B Northwoods Parkway
 Charlotte, NC 28269
 T 704 921 9303, F 704 921 1960
www.domnickhunter.com

Engine Filtration & Water Purification

Racor
 3400 Finch Road, PO Box 3208
 Modesto, CA 95353
 T 209 521 7860, F 209 529 3278
www.parker.com/racor

Racor
 850 North West St., PO Box 6030
 Holly Springs, MS 38635
 T 662 252 2656, F 662 274 2118
www.parker.com/racor

Racor
 302 Parker Drive
 Beaufort, SC 29906
 T 843 846 3200, F 843 846 3230
www.parker.com/racor

Racor -- Village Marine Tec.
 2000 West 135th Street
 Gardena, CA 90249
 T 310 516 9911, F 310 538 3048
www.villagemarine.com

Hydraulic Filtration

Hydraulic Filter
 16810 Fulton County Road #2
 Metamora, OH 43540-9714
 T 419 644 4311, F 419 644 6205
www.parker.com/hydraulicfilter

Process Filtration

Process Advanced Filtration
 2340 Eastman Avenue
 Oxnard, CA 93030
 T 805 604 3400, F 805 604 3401
www.parker.com/processfiltration

Europe

Compressed Air Treatment
domnick hunter Industrial
 Dukesway, Team Valley Trading Estate
 Gateshead, Tyne & Wear
 England NE11 OPZ
 T +44 (0) 191 402 9000,
 F +44 (0) 191 482 6296
www.domnickhunter.com

Hiross Zander
Padova Business Unit
 Strada Zona Industriale 4
 35020 S. Angelo di Piove Padova, Italy
 T +39 049 9712 111, F +39 049 9701 911
www.dh-hiross.com

Hiross Zander
Essen Business Unit
 Zander Aufbereitungstechnik GmbH
 Im Teelbruch 118
 D-45219 Essen, Germany
 T +49 2054 9340, F +49 2054 934164
www.zander.de

Parker Gas Separations
 Oude Kerkstraat 4
 P O Box 258
 4870 AG Etten- Leur, Netherlands
 T +31 76 508 5300, F +31 76 508 5333

Engine Filtration & Water Purification

Racor
 Shaw Cross Business Park
 Churwell Vale Dewsbury,
 WF12 7RD England
 T +44 (0) 1924 487000,
 F +44 (0) 1924 487038
www.parker.com/rfde

Racor Research & Development
 Parker Hannifin GmbH & Co KG
 Inselstrasse 3 - 5
 70327 Stuttgart Germany
 T +49 (0)711 7071 290-0,
 F +49 (0)711 7071 290 -70
www.parker.com/racor

Hydraulic Filtration

Hydraulic Filter
 Stieltjesweg 8, 6827 BV
 P.O. Box 5008 6802 EA
 Arnhem, Holland
 T +31 26 3760376, F +31 26 3643620
www.parker.com/eurofilt

Ujala Operation
 Salmentie 260
 31700 Ujala as Finland
 T +358 20 753 2500, F +358 20 753 2501
www.parker.com/fi

Condition Monitoring Center
 Brunel Way Thetford,
 Norfolk IP 24 1HP England
 T +44 1842 763299, F +44 1842 756300
www.parker.com/cmcc

Process Filtration

domnick hunter Process
 Durham Road, Birtley Co. Durham,
 DH3 2SF England
 T +44 (0) 191 410 5121,
 F +44 (0) 191 410 5312
www.domnickhunter.com

Asia Pacific

Australia
 9 Carrington Road, Castle Hill
 NSW 2154, Australia
 T +61 2 9634 777, F +61 2 9899 6184
www.parker.com/australia

China
 280 YunQiao Road
 JinQiao Export Processing Zone
 Shanghai 101206 China
 T +86 21 5031 2525, F +86 21 5834 3714
www.parker.com/china

India

Plot EL 26, MIDC, TTC Industrial Area
 Mahape, Navi Mumbai 400 709 India
 T +91 22 5613 7081, 82, 83, 84, 85
 F +91 22 2768 6618 6841
www.parker.com/india

Japan

626, Totsuka-cho, Totsuka-ku
 Yokohama-shi, 244-0003 Japan
 T +81 45 870 1522, F +81 45 864 5305
www.parker.com/japan

Korea

1-C Block, Industrial Complex of Jangan,
 615-1, Geumui-Ri Jangan-Myeon,
 Hwaseong-City Gyeonggi-Do, Korea
 T +82 31 359 0771, F +82 31 359 0770
www.parker.com/korea

Singapore

11, Fourth Chin Bee Road
 Singapore 619 702
 T +65 6887 6300, F +65 6261 4929
www.parker.com/singapore

Thailand

1023 3rd Floor, TPS Building
 Pattanakam Road, Suanluang,
 Bangkok 10250 Thailand
 T +66 2717 8140, F +66 2717 8148
www.parker.com/thailand

Latin America

Parker Comercio Ltda.

Filtration Division
 Estrada Municipal Joel de Paula
 900 Eugenio de Melo,
 Sao Jose dos Campos
 CEP 12225-390 SP Brazil
 T +55 12 4009 3500, F +55 12 4009 3529
www.parker.com/br

Pan American Division - Miami

7400 NW 19th Street, Suite A
 Miami, FL 33128
 T 305 470 8800 F 305 470 8808
www.parker.com/panam

Africa

Parker Hannifin Africa Pty Ltd
 Parker Place, 10 Berne Avenue,
 Aeroport Kempton Park,
 1620 South Africa
 T +27 11 9610700, F +27 11 3927213
www.parker.com/au

